

2

WIRELESS TELEGRAPHY



McGraw-Hill Book Co. Inc.

PUBLISHERS OF BOOKS FOR

Coal Age ▽ Electric Railway Journal
Electrical World ▽ Engineering News-Record
American Machinist ▽ The Contractor
Engineering & Mining Journal ▽ Power
Metallurgical & Chemical Engineering
Electrical Merchandising

WIRELESS TELEGRAPHY

BY

DR. J. ZENNECK,

PROFESSOR OF PHYSICS AT THE TECHNICAL HIGH SCHOOL OF MUNICH.

TRANSLATED FROM THE GERMAN

BY

A. E. SEELIG, E. E.

FIRST EDITION

FIFTH IMPRESSION

McGRAW-HILL BOOK COMPANY, INC.

239 WEST 39TH STREET. NEW YORK

LONDON: HILL PUBLISHING CO., LTD.

6 & 8 BOUVERIE ST., E. C.

1915

TK 5741
Z 4

placement
322644

COPYRIGHT, 1915, BY THE
MCGRAW-HILL BOOK COMPANY, INC.

First printing, August, 1915

Second printing, May, 1916

Third printing, July, 1917

Fourth printing, January, 1918

Fifth printing, March, 1918

322644
TK 5741
Z 4

TK 574
24

EXTRACT FROM AUTHOR'S PREFACE TO THE FIRST EDITION

This book was written at the suggestion of the publisher, Dr. Enke. It was originally intended to be an abridged form of my larger book "Elektromagnetische Schwingungen und drahtlose Telegraphie" (Stuttgart, 1905). It has, however, developed into something quite different; evidence of this lies in the fact that only 79 of the 332 illustrations of the larger book have been reproduced here.

Since I began writing this book (winter 1905-1906) conditions in wireless telegraphy have changed greatly. The mere fact that new devices and methods have appeared would be of relatively little importance; but the points of view determining the consideration of many of the problems of the art have changed entirely. This necessitated rewriting many portions of the book, which would otherwise have been out of date from its very publication. I need hardly dwell on what this has meant for both the publisher and myself.

The mathematical premises are the same as in my larger book. In the text, knowledge of only elementary mathematics—the use of differential and integral calculus would have offered no advantage,—in the Notes, knowledge of the electromagnetic theory is assumed. The physical premises are somewhat higher than in the larger book; knowledge of experimental electro-physics and of the phenomena of alternating currents, in short the ground covered by the first four chapters of my larger book, is necessary for a thorough understanding of this volume.

I have been somewhat more sparing with the bibliography, for since a year ago, Dr. G. Eichhorn, in the "Jahrbuch für drahtlose Telegraphie," gives detailed references to the literature on the subject.

As regards the commercial form of the apparatus, most frequent reference has been made to the German manufacturers (Ges. f. drahtl. Tel. and Amalgamated Radio-telegraph Co., *i.e.*, C. Lorenz, A. G.). In so doing I had no desire to show these firms any preference. Description of all the different makes of apparatus would have been prohibitive, and I have simply chosen as examples the apparatus of those firms which placed exact data and photographs at my disposal. Moreover other makes of apparatus are fully described in other books; I might mention the excellent works of J. A. Fleming and particularly of J. Erskine-Murray in this connection.

J. ZENNECK.

BRAUNSCHWEIG, PHYSIKALISCHES INSTITUT
DER TECHNISCHEN HOCHSCHULE,
Dez., 1908.

AUTHOR'S PREFACE TO THE SECOND EDITION

Only two and a half years after the appearance of the first edition, a second one has become necessary, even though a French edition had already appeared in the meantime. The book, therefore, has been accorded a much more favorable reception than I had dared hope.

This served particularly to spur me on to do everything within my power to make the second edition representative of the present status of wireless telegraphy. Due to its rapid development, this meant an extensive revision of the entire book.

Unfortunately I found it impossible to carry out this revision without extending the scope. In view of this wider scope, the book has been renamed "Textbook" ("*Lehrbuch*") instead of "Elements" ("*Leitfaden*") "of Wireless Telegraphy."

In choosing my subject matter, I was guided chiefly by the standpoint of the physicist. I have frequently discussed arrangements or devices involving a new physical idea, even though knowing that they had either not been used to date or are no longer used in practice. To confine ourselves to what is of practical importance will only be proper when once it has been fixed what really is of "practical importance." On this point, however, the views of experts have changed very rapidly during recent years; even to-day individual views diverge widely and seem to be influenced less by scientific reasons than by patent rights.

Unquestionably, theoretical investigation, laboratory experiments and experiences in practice have cleared much in recent years. Nevertheless, there still remain a number of problems which find no answer in the results obtained to date. If then my presentation of these problems falls short of the necessary clearness, the fault does not rest entirely with me.

In this edition, as in the first, I have received friendly cooperation from many sources: from Dr. L. W. Austin (Washington, D. C.), H. Boas (Berlin), Dr. L. Cohen (Brant Rock), F. Ducretet and E. Roger (Paris), Dr. Erskine-Murray (London), the Gesellschaft für drahtlose Telegraphie (Telefunken Co., Berlin), Dr. E. Huth (Berlin), the C. Lorenz Co. (Berlin), the Marconi Wireless Telegraph Co. (London), Dr. E. Nesper (Berlin), Dr. E. H. Riegger and Dr. Rukop (Danzig), Dr. G. Seibt (Berlin), the Société française de radioélectrique (Paris), and Prof. C. Tissot (Brest). To all these I herewith express my thanks.

Particular thanks are due Dr. A. Meissner (Berlin), Prof. Vollmer (Jena), and Prof. M. Wien (Jena). These have gone to the great trouble of reading through the entire proof, and by their valuable advice have guarded me against many errors and defects.

Lastly, I thank the publisher, Dr. A. Enke (Stuttgart) for the kind interest he has evidenced in the preparation of the book in its final form.

J. ZENNECK.

DANZIG-LANGFUHR, PHYSIKALISCHES INSTITUT
DER TECHNISCHEN HOCHSCHULE,
Nov., 1912.

TRANSLATOR'S INTRODUCTORY NOTE

Few students of wireless telegraphy need to be introduced to "Zenneck." To many, however, this splendid work has remained a "closed book" due to lack of knowledge of the author's language. Hence this translation—in the hope that it will fill a real need.

Aside from the comprehensiveness of the work as a text-book, the author, without failing to give full credit to the best that has been done in America, naturally pays most attention to the work done in Europe, especially in Germany, and thus gives us an insight into the excellent results accomplished abroad by inventors and engineers in developing the art based on Marconi's fundamental invention.

Rather than take the risk of distorting the author's precise meaning, the translator has at times retained a very literal translation in preference to adopting the customary English phraseology. Moreover, when tempted to add something to or modify the original (as for instance in connection with recent "high frequency" apparatus), the translator finally decided to let Zenneck be Zenneck.

A word of thanks is due to Dr. L. W. Austin for occasional friendly assistance, as well as to the publishers for their cooperation in the preparation of the book.

A. E. SEELIG.

WELLSVILLE, N. Y.,
August, 1915.

CONTENTS

CHAPTER I

THE NATURAL OSCILLATIONS OF CONDENSER CIRCUITS

	PAGE
1. Oscillations Produced by Charging the Condenser.	1
§1. <i>The Frequency</i>	
2. Experimental Determination of the Frequency	3
3. Calculation of Frequency (Thomson's Equation)	6
4. Condensers in Series and in Parallel	7
5. The Practical Importance of Thomson's Equation.	9
§2. <i>The Damping</i>	
6. The Transfer of Energy	9
7. The Various Causes of Damping	11
8. Condenser Circuit without Spark Gap. Damping Due to Heat Loss.	11
9. Condenser Circuit with Spark Gap. Damping Due to Spark.	13
10. Methods for Determining the Spark Gap Damping	16
11. The Factors Which Determine the Amount of Gap Damping	16
12. Spark Gaps in Series (Multiple Gaps).	20
13. Energy Losses in the Dielectric of the Condensers.	20
14. Energy Lost by Leakage Discharge	21
15. Energy Lost by Eddy Currents.	22
16. Relative Importance of the Various Energy Losses	23

CHAPTER II

OPEN OSCILLATORS

§1. <i>The Lineal Oscillator</i>	
17. The Fundamental and Upper Harmonic Oscillations.	24
18. Current and Potential Distribution in the Fundamental Oscillation.	24
19. Frequency of the Fundamental Oscillation	26
20. The Electromagnetic Field of the Fundamental Oscillation.	27
21. Damping of the Fundamental Oscillation	31
22. Upper Harmonics of the Lineal Oscillator	32
23. Coils	33
§2. <i>General Properties of Open Oscillators</i>	
24. Current and Potential Distribution along a Wire	34
25. The Electromagnetic Field at Great Distances from the Oscillator.	35
26. The Radiation of an Oscillator	39
27. Effective Capacity and Effective Self-inductance of an Oscillator	40
§3. <i>Various Forms of Complex Oscillators</i>	
28. Lineal Oscillator with Two Equal Capacities, One at Each End (Hertz Oscillator).	41
29. Lineal Oscillator with Capacity at One End	42
30. Lineal Oscillator Containing Series Condensers	43
31. Lineal Oscillator Containing Series Inductance	44
32. Lineal Oscillator with Both Inductance and Capacity	45
33. Grounded Oscillators	46

CHAPTER III

THE HIGH FREQUENCY ALTERNATING-CURRENT CIRCUIT

	PAGE
§1. <i>Resistance, Self-induction and Capacity</i>	
34. Current Distribution in Cross-section of Solid Wires	47
35. Coefficient of Self-induction	47
36. Resistance of Straight Wires	48
37. Resistance of Coils	50
38. Coils Having Variable Self-induction	51
39. Condensers of Constant Capacity	54
40. Variable Condensers	59
§2. <i>Current and Voltage</i>	
41. Relations between Current and Voltage Amplitudes	62
42. The Break-down Voltage and Gap Length	64
43. Insulation of Conductors	66
§3. <i>Measurement of Current</i>	
44. The Indications of Hot-wire Instruments	67
45. Commercial Hot-wire Instruments	71
46. The Hot-wire Air Thermometer	71
47. Bolometer, Barretter	72
48. Thermoelement or Thermocouple	74
49. The Thermogalvanometer	75
50. Comparison of the Sensitiveness of Various Measuring Instruments	76
51. Measurement of Very Small Currents	76

CHAPTER IV

COUPLED CIRCUITS

§1. <i>Coupling in General</i>	
52. Magnetic, Galvanic, Electric Coupling	79
53. Loose and Close Coupling	81
54. Methods of Coupling	82
§2. <i>Loose Coupling of Damped Oscillating Circuits</i>	
55. Coupling of Oscillator to Closed Circuit	84
56. Extremely Loose Coupling of Two Oscillators	85
57. Loose Coupling of Two Oscillators	87
§3. <i>Close Coupling of Tuned, Damped Oscillating Circuits</i>	
58. Form of the Oscillations	87
59. The Frequency of Coupling Waves	88
60. The Decrements of Coupling Waves	90
61. Amplitude and Phase of the Oscillations	91
§4. <i>Quenching Action in Coupled Circuits</i>	
62. Form of the Oscillations	93
63. Various Types of Quenched Gaps	95
64. Requirements for Good Quenching	95
65. Concerning the Nature of the Quenching Action	97
§5. <i>The Coupling of Undamped Oscillating Circuits</i>	
66. Coupling with a Closed Circuit	99
67. Loose Coupling with an Oscillator	100
68. Close Coupling with an Oscillator	101
69. Difference between Damped and Undamped Oscillations	103

CHAPTER V

RESONANCE CURVES

	PAGE
§1. <i>The Resonance Curve of the Current Effect</i>	
70. General Remarks	104
71. Measurement of the Frequency	106
72. Calibration of the Measuring Circuit	108
73. Determination of Capacities and Coefficients of Self and Mutual Induction by Resonance	112
74. Determination of the Sum of the Decrements of the Primary and Secondary Circuits (v. Bjerknes)	113
75. Abnormal Forms of the Resonance Curves	116
76. Determination of the Decrements of the Primary and Secondary Circuits	118
77. Measurement of Small Changes in the Decrement.	120
78. Measurements with Resonance Circuits in General	120
79. Commercial "Wavemeters"	125
§2. <i>Resonance Curve of the Dynamometer Effect</i> (L. Mandelstam and N. Papalexi)	
80. General	132
81. Determination of the Frequency (Wave length).	134
82. Decrement Determination	135
83. The Dynamometer	135
§3. <i>Use of Resonance in the Study of Condensers</i>	
84. Determination of the Frequency Factor	137
85. Energy Absorbed by Dielectric Hysteresis	138
86. The Brush Discharge of Condensers	138
§4. <i>The Use of Resonance Curves for Investigating Coupled Circuits</i>	
87. Coupling of Tuned Circuits	142
88. Close Coupling of Tuned Circuits	145
89. Coupling Untuned Circuits.	147
90. Investigation of the Quenching Action in Spark Gaps	148

CHAPTER VI

THE ANTENNA

91. General	150
§1. <i>The Various Kinds of Antennæ</i>	
92. Form of the Aerials	150
93. Comparison of the Different Forms of Aerials.	155
§2. <i>Grounding</i>	
94. Ground and Counterpoise	157
95. Energy Consumed by the Earth Currents	158
96. Ungrounded Antennæ for Airships	163
§3. <i>The Oscillations of Antennæ</i>	
97. Frequency, Capacity and Self-induction	164
98. Regarding the Effect of Coils	165
99. The Damping of Antennæ and Its Causes	167
100. Determination of the Decrement	168

CHAPTER VII

TRANSMITTERS OF DAMPED OSCILLATIONS

	PAGE
101. The Different Types of Transmitters	173
§1. <i>The Simple (Marconi) Transmitter</i>	
102. General	173
103. The Damping	174
§2. <i>The Braun Transmitter</i>	
104. Nature of the Coupling	175
105. Coupled Transmitter for Antennæ Having High Damping. Very Loose Coupling	175
106. Coupled Transmitter for Antennæ Having High Damping. Close Coupling.	176
107. Coupled Transmitters for Slightly Damped Antennæ	178
108. Commercial Form of the Braun Transmitter	179
§3. <i>Quenched Spark Gap Transmitter (Wien's Transmitter)</i>	
109. Impulse Excitation	182
110. The Connections	184
111. Practical Construction of Quenched Spark Gaps	186
112. Commercial Construction of the Wien Transmitter	192
§4. <i>General Consideration of Transmitters of Damped Oscillations</i>	
113. Operation by Means of Interrupted Direct Current	194
114. Alternating-current Operation	195
115. Direct-current Operation	198
116. Measurement of Energy Supplied; Determination of the Efficiency	200
117. The Key	202
118. Spark Gaps with Rotating Electrodes	203
§5. <i>Comparison of the Different Types of Transmitters</i>	
119. Difference between the Coupled and the Simple (Marconi) Transmitter	208
120. Comparison of the Braun and Wien Transmitters.	210

CHAPTER VIII

HIGH FREQUENCY MACHINES FOR UNDAMPED OSCILLATIONS

121. The Alexanderson-Fessenden Machines	213
122. Goldschmidt's High Frequency Generator	216

CHAPTER IX

UNDAMPED OSCILLATIONS BY THE ARC METHOD

§1. <i>The Various Arrangements</i>	
123. The Problem and the Solution by V. Poulsen	220
124. Commercial Construction of the Poulsen Generators.	222
125. Use of the Poulsen Arc for Measuring Purposes	225
126. Circuit Connections of the Poulsen Transmitter.	227
127. Devices for Producing Signals	228
128. The Multitone Transmitter of J. C. Lorenz.	229
§2. <i>Study of the Action of the Arc</i>	
129. Characteristic of the Arc.	231
130. Type I Oscillations: $I_{10} < I_0$	233

	PAGE
131. Type II Oscillations: $I_{1_0} > I_0$; no Re-ignition	234
132. Type III Oscillations: $I_{1_0} > I_0$; Re-ignition Present	236
133. Energy of the Oscillations	237
134. Frequency of the Oscillations ²¹⁵	238
135. Practical Conclusions for Type II Oscillations	239
136. Regularity of Type II Oscillations.	241
137. The Terms "Spark" and "Arc" ²¹⁷	245

CHAPTER X

PROPAGATION OF THE WAVES OVER THE EARTH'S SURFACE

§1. <i>Over Plane or Spherical Homogeneous Ground</i>	
138. Ground Having Plane Surface and High Conductivity.	246
139. Over Flat Ground of Not Very High Conductivity	248
140. Effect of the Spherical Shape of the Earth	255
§2. <i>Wave Propagation over Uneven or Non-homogeneous Ground</i>	
141. Uneven Surfaces	258
142. Rain and Ground Water	260
143. Distribution over Land and Water	262
§3. <i>Effect of Atmospheric and Other Influences upon the Waves</i>	
144. Effect of the Condition of the Atmosphere	263
145. Ionization of the Atmosphere.	264
146. Actual Measurements of the Wave Propagation.	269
147. Effect of Grounding the Transmitter upon the Wave Propagation.	270
148. The Safety Factor	271

CHAPTER XI

DETECTORS²⁴⁷

§1. <i>Thermal Detectors</i>	
149. Bolometer and Thermogalvanometer.	272
150. Thermocouples, Thermal Detectors	273
151. Relative Importance of the Thermal Detectors	274
§2. <i>Magnetic Detectors</i> ²⁵¹	
152. The Fundamental Physical Principles	274
153. Marconi's Magnetic Detector.	274
154. Other Forms of Magnetic Detectors.	275
§3. <i>Imperfect Contacts</i>	
155. Metallic Granular Coherer ²⁵⁵	276
156. Mercury Coherers.	278
157. Carbon or Graphite Coherers. (Microphone Contact).	279
§4. <i>Electrolytic and Other Detectors</i>	
158. Anticoherers	279
159. The Electrolytic Detectors of FERRIÉ, FESSENDEN, NERNST, and SCHLÖMILCH	280
160. Crystal Detectors.	282
161. Incandescent Lamp Detectors. Gas Detectors	283
§5. <i>General Consideration of Detectors</i>	
162. The Nature of the Action in Various Detectors	285
163. What do the Different Types of Detectors React upon?	287
164. Testing the Sensitiveness of Detectors	289

	PAGE
§6. <i>Receiving Apparatus</i>	
165. Telephone Reception	290
166. Amplification of the Sound in Telephone Reception	291
167. Automatic Recording of Messages.	294
168. Recording Apparatus for the Metallic Granular Coherer.	298
169. Call Signals	299
170. Comparison of the Different Kinds of Detectors	300

CHAPTER XII

RECEIVERS

171. The Aerials of the Receiving Stations	303
172. General Consideration of the Receiving System	304
§1. <i>The Original Marconi Receiver</i>	
173. The First Arrangement	307
174. The Marconi Transformer	308
§2. <i>Receivers for Tuned Telegraphy with Damped Oscillations</i>	
175. Receivers for Highly Damped Receiving Antennæ.	310
176. Receivers for Weakly Damped Antennæ	313
177. Tuning the Receiver for a Double Wave Transmitter	314
178. Adjustment of the Energy Delivered to the Receiver	314
179. Receivers for Two Different Detectors.	315
180. The Sharpness of Tuning	316
181. R. A. Fessenden's Method for Maintaining Secrecy of Telegrams.	323
182. Multiple Telegraphy.	324
183. Methods for Overcoming Atmospheric Disturbances.	326
184. Achievements of Tuned Telegraphy	328
185. Methods for Preserving Secrecy of Messages	330
§3. <i>Receivers for Undamped Oscillations</i>	
186. General	332
187. Methods Employing the Ordinary Detector	333
188. The Ticker.	334
189. Construction of Interrupter for Ticker Method	335
190. Special Arrangements for Undamped Oscillations	335
191. Practical Achievements	336

CHAPTER XIII

DIRECTIVE TELEGRAPHY

192. Characteristic of the Distance Effect.	338
§1. <i>The First Attempts</i>	
193. Use of Reflectors	340
194. Attempts at Screening.	340
§2. <i>Methods Employing Several Antennæ</i>	
195. The Field of Several Antennæ—General Consideration.	341
196. The Field of Several Antennæ—Special Cases.	342
197. Double Antennæ, One-half Wave Length Apart.	345
198. The Methods of E. Bellini and A. Tosi	347
199. The Methods of F. Braun	352

	PAGE
200. Production of Any Desired Phase Difference with Undamped Oscillations	352
201. Production of Any Desired Phase Difference with Damped Oscillations	353
§3. <i>Aerials Having Horizontal or Inclined Portions</i>	
202. Marconi's Bent Antenna	356
203. The Action of the Bent Marconi Antenna when Transmitting	357
204. The Bent Marconi Antenna Used for Receiving	361
205. Inclined Antennæ	363
206. Horizontal Antennæ. Ground Antennæ	364
207. The Advantages of Directive Signalling	365

CHAPTER XIV

WIRELESS TELEPHONY

§1. <i>The Transmitter</i>	
208. Source of Energy	371
209. Connections	371
210. Microphones	373
§2. <i>The Receiver</i>	
211. Connections	374
212. The Action in the Detector Circuit	376

The Development of Wireless Telegraphy During the Years 1909-1912

TABLES

Table I. The Natural Frequency of Condenser Circuits	384
" II. The Natural Wave Length of Condenser Circuits	386
" III. Frequency and Wave Length	388
" IV. Oscillation Curves for Various Decrements	389
" V. The Spark (Arc) Constants	392
" VI. Equations for Calculations of the Coefficient of Self-induction	393
" VII. Effective Resistance of Copper Wires	396
" VIII. Maximum Diameter of Resistance Wires	398
" IX. Gap Lengths and Corresponding Minimum Discharge Voltages	399
" X. Determination of Percentage Coupling	401
" XI. Resonance Curve of the Current Effect	403
" XII. Resonance Sharpness	405
" XIII. The Radiation Resistance of Antennæ	405

BIBLIOGRAPHY AND NOTES ON THEORY

INDEX	408
-----------------	-----

SYMBOLS AND ABBREVIATIONS

The following explanations of symbols and abbreviations used in the text apply throughout unless distinctly stated otherwise:

- E = Electric field strength
- M = Magnetic field strength
- \mathcal{E} = Electromotive force = e.m.f.
- μ = Permeability
- ϵ = Dielectric constant
- ϵ_0 = Dielectric constant of air
- $k = \frac{\epsilon}{\epsilon_0}$, usually referred to as the dielectric constant

mf. = Microfarad

c.g.s. = Units of the absolute electromagnetic (centimeter-gram-second) system

Σ = Radiation

W = Energy

W_e = Energy of the electrical field

W_m = Energy of the magnetic field

V = Voltage

V_z = Ignition voltage

I = Current (frequently i is used in the illustrations)

r = Resistance

L_s = Coefficient of self-induction } for stationary field

C_s = Capacity

R = Resistance

L = Coeff. of self-induction } for oscillations

C = Capacity

Ls_{1_2} or Ls_{2_1} = Coeff. of mutual induction with quasi stationary current

L_{1_2} or L_{2_1} = Coeff. of mutual induction with non-quasi stationary current

R_g = Gap resistance

R_Σ = Radiation resistance

K = Coeff. of coupling

K' = Degree or percentage of coupling

T = Period

N = Frequency = number of complete periods per second

$\omega = 2\pi T = \frac{2\pi}{N}$ = number of periods in 2π seconds = circuit frequency

λ = Wave length

V_L = Velocity of propagation

ζ = Discharge frequency = number of discharges per second

d = (Logarithmic) decrement

d_j = Joulean decrement

d_h = Hysteresis decrement

d_Σ = Radiation decrement

d_g = Gap decrement

a = Lineal decrement

- α = Form factor of an antenna
 ρ = Sharpness of resonance
 a, b = Constants of the spark or arc
 e = Base of the natural (Naperian) logarithms
 \propto = Proportional to; varies as
 \ll = Much less than
 \gg = Much greater than
EMS = Zenneck's "Elektromagnetische Schwingungen u. drahtlose Telegraphie." Stuttgart, 1905.
ETZ = Elektrotechnische Zeitschrift
Jahrb. = Jahrbuch für drahtlose Telegraphie. Leipzig. Joh. Amer. Barth.
El. = The Electrician. London.
C.R. = Comptes rendus de l'Academie des Sciences. Paris.

WIRELESS TELEGRAPHY

CHAPTER I¹

THE NATURAL OSCILLATIONS OF CONDENSER CIRCUITS

1. **Oscillations Produced by Charging the Condenser.**—The simplest form of a condenser circuit is that shown in Fig. 1: a condenser, C , and a conductor, AFB , joining the metallic coatings of the condenser.

a. Let this circuit be broken at some point, F , and each side connected to one pole of an electric influence machine, an induction coil or an alternating-current transformer (Fig. 2). If then the influence machine or induction coil is put into operation, the condenser becomes charged, one of its coatings, say A , receiving a certain quantity of positive elec-

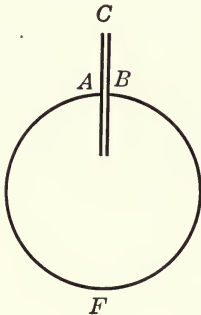

FIG. 1.

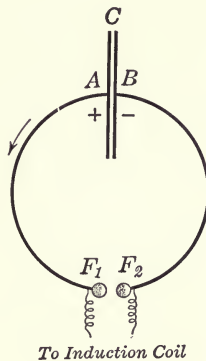

FIG. 2.

tricity, the other, B , an equal amount of negative electricity. The resultant electrical field and difference of potential are obtained not only between the coatings A and B , but also between the poles F_1 and F_2 of the gap in the circuit. If the condenser charge and thereby the tension between F_1 and F_2 are gradually increased, a "spark" finally passes between F_1 and F_2 and the space F_1F_2 , the "spark gap," becomes conductive.

b. The difference in potential between the coatings A and B produces an electric current in the direction of the arrow in Fig. 2, from the positive to the negatively charged coating. This holds good only at the start, however. For the current, assuming that the resistance of the conductors

AF_1 and F_2B is not extremely high, is an **oscillating** or **alternating** current of the kind represented by the curve in Fig. 3, a photographic reproduction made by the aid of BRAUN'S Kathode Ray Tube,² which is specially adapted for such purposes. The abscissæ of the curve are proportional to the time, the ordinates to the current values at any instant.

This alternating current is in one respect distinctly different from the alternating currents in ordinary commercial use as produced by *A.C.* generators, viz., it has a constantly decreasing amplitude. An alternating current of this kind is said to be "**damped**" to distinguish it from an "**undamped**" alternating current of constant amplitude.

c. As every current produces a magnetic field whose strength, at least in the vicinity of the current-carrying conductor, is proportional to the current, it may be concluded that the magnetic field varies similarly to the current; it is a "**damped alternating magnetic field.**"

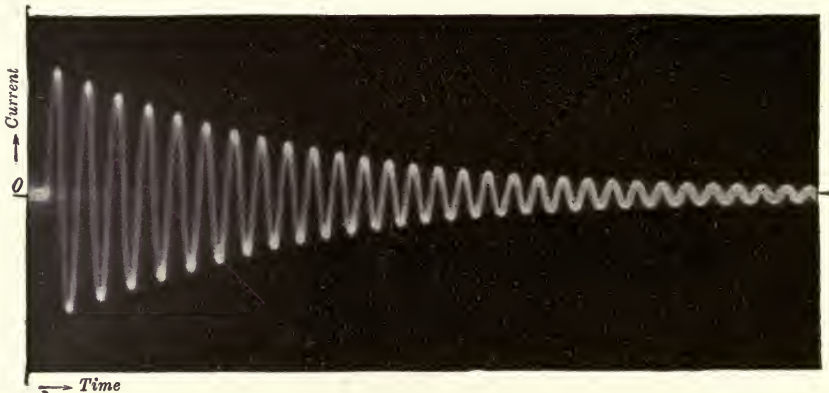

FIG. 3.

During the period in which the current has the direction shown in Fig. 2, it must bring a positive charge from the coating *A* to *B*, and when its direction is reversed, its action upon the condenser coatings is also reversed. Hence the condenser charge also oscillates and the electric field between its coatings is also a damped alternating field.

d. The entire phenomenon, *i.e.*, the alternating current with its accompanying alternating electric and magnetic fields is called an "**electromagnetic oscillation.**"

Oscillations, which, as in this case, may be produced in a condenser circuit without the influence of other oscillations, are said to be the "**natural**" or "**free oscillations**" of that circuit.

e. With the arrangement of Fig. 2, the natural oscillations are caused by the spark. In general, however, the presence of a spark is not essential for the production of natural oscillations, which may also be obtained in a condenser circuit having no spark gap [Art. 109].

1. FREQUENCY

2. **Experimental Determination of the Frequency.**—*a.* Even with condenser circuits, whose natural oscillations are too rapid to allow of photographic reproduction by the aid of a Braun tube (see Fig. 3) or an oscillograph, the “frequency” of the oscillation, *i.e.*, the number of complete cycles per second, can be *directly* determined by means of a rotating mirror—FEDDERSEN’S method—if the condenser circuit contains a spark gap. The gap, placed in a horizontal position and viewed in a mirror which rotates about a horizontal axis—*e.g.*, fixed on the shaft of a small electric motor (Fig. 4)—appears during a discharge in the form shown in Fig. 5. At those moments during which the current passing over the gap is a maximum, the most light is produced in its path, which is very dark when the current is at its minimum; so that the illumination

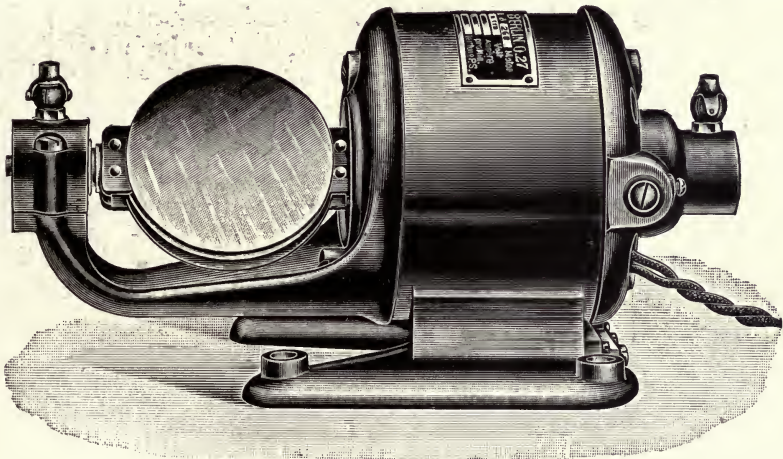

FIG. 4.

of the path of the discharge varies periodically with the current. Hence, in the rotating mirror, in which the successive images of the spark appear at different points, a row of alternately light and dark stripes is obtained.

The distance between two adjacent light stripes corresponds to the time of a half period of the oscillation. If the image in the rotating mirror is photographed and if, from the number of revolutions of the mirror and the dimensions of the apparatus, the speed with which the image of the spark moves over the photographic plate is determined, then the time of one cycle and hence the frequency of the oscillations are easily obtained from the distance between two or more light stripes.

This method is not only of great practical value, but is of special interest as having been used by W. FEDDERSEN³ in the *first experimental*



FIG. 5.

demonstration and study of the natural oscillations of condenser circuits, which constitute the foundation of the science of modern radio-telegraphy.

b. Gehrke's incandescent oscillograph tube offers another method for the direct determination of the frequency of condenser circuits.⁴

It consists of a glass tube of the form shown in Fig. 6a, with wire or sheet metal electrodes (Fig. 6b) and filled with pure nitrogen under slight pressure. If current is sent through this tube, the length of the incandescent portion of the negative electrode is approximately proportional to the strength of the current. If the tube is connected through a sufficiently high series resistance (tube of water, R , in Fig. 7) to the condenser coatings, then the current passing through it, and hence also the length of the incandescence, are proportional at any instant to the voltage between the condenser coatings. By photographing the image of the tube in a mirror whose axis is parallel to the axis of the tube (Fig. 8)*, a picture of the form shown in Fig. 9 (H. DIESELHORST)⁴ is obtained. The distance between the light stripes is a measure of the duration of a cycle (see *a*).

As this tube absorbs considerable energy and as the length of the negative incandescence is not always exactly proportional to the amount of current passing through it, it is

adapted for demonstration purposes rather than for accurate measurements.

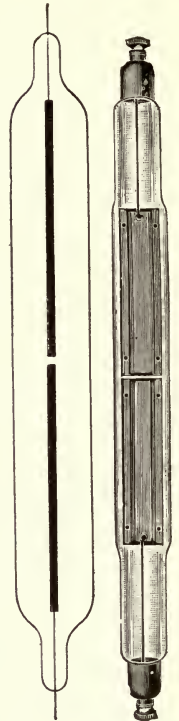

FIG. 6a. FIG. 6b.

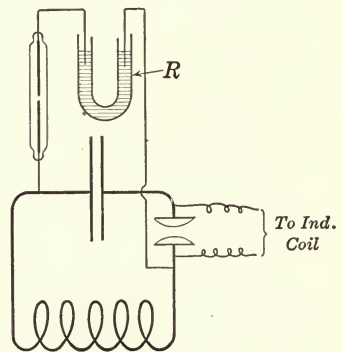

FIG. 7.

* Fig. 8 shows oscillograph made by the firm H. Boas: the tube is in a box at the upper right and below this is the holder for the photographic plate upon which the concave mirror, mounted on the shaft of the motor, reflects the image of the tube.

c. More convenient but indirect methods for determining the frequency will be discussed later [Art. 71, 81].

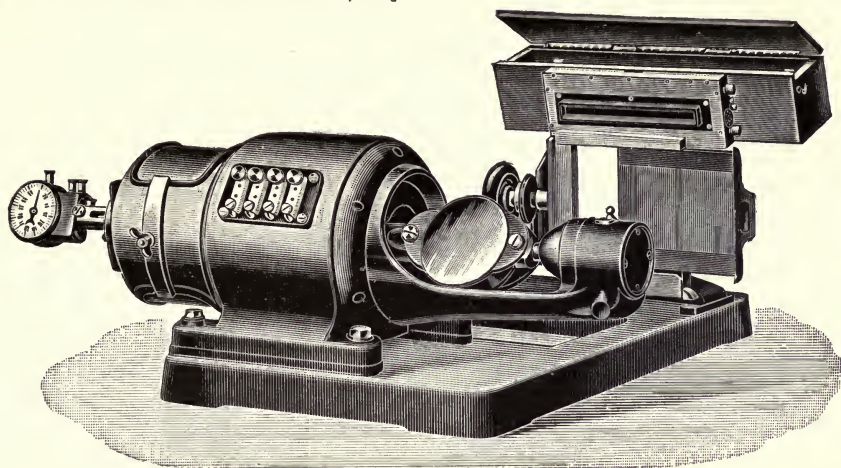

FIG. 8.

3. Calculation of Frequency (THOMSON'S EQUATION).—*a.* The following formula for the natural frequency, N , of condenser circuits has been deduced by LORD KELVIN (SIR WILLIAM THOMSON^{5,1}):

$$N = \frac{1}{2\pi} \sqrt{LC} \quad [\text{Table I}]^*$$

$$\omega = 2\pi N = \frac{1}{\sqrt{LC}} \quad \dagger$$

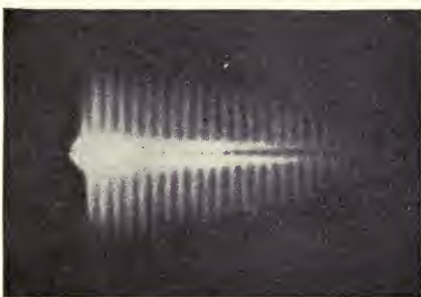

FIG. 9.

in which L is the coefficient of self-induction of the circuit and C its capacity, while ω is the number of oscillations in 2π seconds. Similarly the period, T , of the oscillation is given by

$$T = \frac{1}{N} = 2\pi\sqrt{LC}$$

* This relation holds only if the damping is not extremely great (*i.e.*, $d < 2\pi$) and, therefore, applies to all practical cases. The exact formula is:

$$N = \frac{1}{2\pi\sqrt{LC}} \cdot \frac{1}{\sqrt{1 + \left(\frac{d}{2\pi}\right)^2}}$$

where d = the decrement [Art. 8].

† The wave length [Art. 19] is given by:

$$\begin{aligned} \lambda &= 2\pi V_L \sqrt{LC} = 6\pi \sqrt{L_{C.G.S.} \cdot C_{C.G.S.}} \cdot 10^{10} \text{ cm.} \\ &= 6\pi \sqrt{10} \cdot \sqrt{L_{C.G.S.} \cdot C_{MF}} \text{ meters} \\ &= 59.61 \sqrt{L_{C.G.S.} \cdot C_{MF}} = \frac{2\pi}{100} \sqrt{L_{C.G.S.} \cdot C_{cm.}} \text{ meters} \quad (\text{Table II}) \end{aligned}$$

It follows that for a condenser circuit of a given frequency, the product of its capacity and self-induction is a fixed quantity.

b. If the frequency is to be obtained in cycles per second, L and C must be expressed in units of the same absolute system. In the following, unless otherwise stated, the customary absolute *magnetic* system, known as the *C.G.S.* system (centimeter, gram, second-system) is used.

The unit of *capacity* customary in practice, the microfarad (MF), is $\frac{1}{10}^{15}$ of the *C.G.S.* unit.* A Leyden jar of average size usually has a capacity of several thousandths of a MF .

The henry, which is the customary unit for the *coefficient of self-induction* is equal to 10^9 *C.G.S.* units. In wireless telegraphy, however, it is more convenient to express the coefficient of self-induction in *C.G.S.* units, instead of in henrys, as the circuits used for radio-telegraphy usually have coefficients of self-induction of much less than 1 henry.

4. Condensers in Series and in Parallel.—The term “**resultant capacity**” of a number of condensers in what follows will be understood

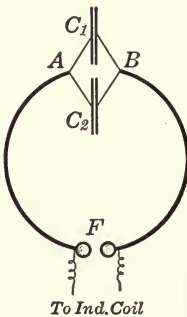

FIG. 10.

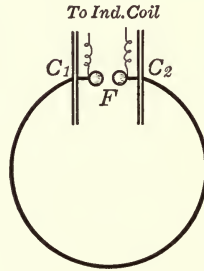

FIG. 11.

as that value of the capacity, which, when substituted for C in Thomson's equation, gives the correct value of the frequency.

a. Where large capacities are required, several condensers must usually be joined in “parallel” (Fig. 10).

If C_1 and C_2 represent the respective capacities of the two condensers in Fig. 10, then the resultant capacity of the condensers in parallel = the sum of their individual capacities, *i.e.*,

$$C = C_1 + C_2$$

If M number of condensers, each having a capacity C_1 , are connected in parallel the resultant capacity $C = M C_1$.

b. Sometimes it may be necessary to connect a number of condensers

* Frequent use is also made in practice of the absolute electric system unit of capacity, the cm. Where formulas involving the cm. are given in this book, this is done, however, only in consideration of current practice.

in "series" (Fig. 11). In this case the resultant capacity C is obtained from the relation

$$\frac{1}{C} = \frac{1}{C_1} + \frac{1}{C_2}$$

so that if $C_1 = C_2$, we have

$$C = \frac{1}{2} C_1$$

If one of the condensers in series has a capacity C_1 which is very much greater than that, C_2 , of the other, the resultant capacity, C , is approximately equal to C_2 , *i.e.*, it, as well as the frequency, is dependent mainly upon the smaller capacity.

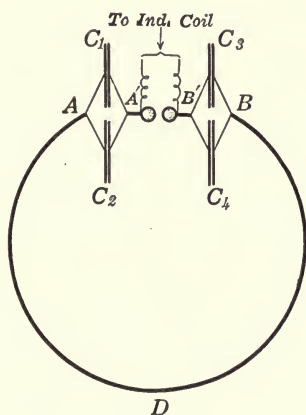

FIG. 12.

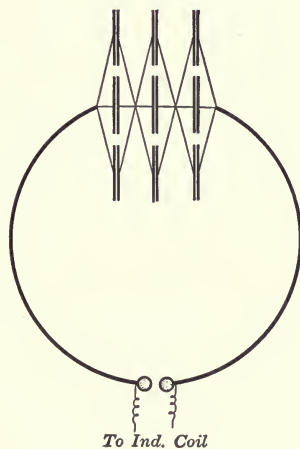

FIG. 13.

c. Figs. 12 and 13 show combinations of series and parallel connections frequently occurring in practice. The resultant capacity in each case, as is easily obtained from the preceding, is,

Fig. 12:
$$\frac{1}{C} = \frac{1}{C_1 + C_2} + \frac{1}{C_3 + C_4}$$

and

Fig 13:
$$\frac{1}{C} = \frac{1}{C_1 + C_2 + C_3} + \frac{1}{C_4 + C_5 + C_6} + \frac{1}{C_7 + C_8 + C_9}$$

If all the condensers are of equal capacity C_1 , then

$$C = C_1$$

so that the resultant capacity of the given combinations of four and nine condensers is the same as that of any one of the condensers placed in the circuit as shown in Fig. 1.

d. Hence, so far as the resultant capacity is concerned, the combina-

tions of Figs. 12, 13 and 2, assuming all the individual condensers to be of equal size, are exactly alike. The difference, this being one of the advantages of the combined series and parallel connections as compared to the single condenser, lies in the distribution of the charge among the individual condensers. In Fig. 2 the potential across the condenser is the same as that between the electrodes of the spark gap, while the potential across each condenser in Fig. 12 is only one-half the total gap potential and in Fig. 13 only one-third of the gap potential.

5. The Practical Importance of Thomson's Equation.—THOMSON'S equation offers a very simple means for rough calculations in determining an approximate value of the frequency or, on the other hand, the value of the capacity required for a given frequency. Usually, however, it is not possible to determine these values with the accuracy required in practice. Not that the Thomson formula is inaccurate, but in condenser circuits having no spark gap, for which alone the Thomson relation holds good, the value of the capacity and coefficient of self-induction are mostly not known exactly; in condenser circuits with a spark gap, the spark affects the frequency.

a. The values of C and L substituted in Thomson's equation must, of course, be those which correspond to that frequency which is to be determined.

For air condensers the capacity C , under the conditions prevalent in wireless telegraph work, is practically the same as the capacity C_s of the same condenser holding a static charge, and can therefore be easily measured with sufficient accuracy.

For condensers, however, having a solid or liquid dielectric, the capacity may vary widely with the frequency. The ratio between capacity C of a condenser in an oscillating circuit to its capacity C_s for a static charge is termed the "frequency factor." When mica or micanite is used as the dielectric this factor may be as low as 0.7–0.8, and for certain kinds of glass it may differ considerably from 1.0, while for other varieties, as for example certain flint glasses, and particularly for certain oils, such as petroleum or well-dried paraffin oil, the frequency factor is practically unity.⁶

b. That care must be taken in choosing the proper value of L , the coefficient of self-induction, for use in Thomson's equation follows from the fact that the value of L may be quite different for the same coil with an alternating than with a direct current [Art. 35].

A further complication arises from the fact that L is the coefficient of self-induction of the entire circuit. For example in the case of Fig. 10 this comprises not only the main conductor AFB , but also the condenser coatings and their leads (AC_1, BC_1, AC_2, BC_2). However, if the circuit contains a coil of several turns this need not be considered, as the rest of the circuit adds very little to the relatively large coefficient of

self-induction of the coil and may be neglected without materially impairing the accuracy. But in some cases it is desirable to keep the self-induction of the circuit *AFB* (Fig. 10) as low as possible and it may happen, especially when using a larger number of condensers with their connections, that the resultant coefficient of self-induction is much greater than the value calculated from the general dimensions of the circuit *AFB*.

c. The frequency of condenser circuits containing a spark gap may vary as much as 10 per cent. from that indicated by Thomson's equation (M. WIEN, H. RIEGGER⁷). However, this variation is great only if the electrodes of the spark gap are made of copper or silver and if the gap itself is at the same time very short (say ≤ 2 mm.)* the variation becomes greater in proportion to the shortness of the gap and the smallness of the condenser, other things being equal.

If tin, zinc, cadmium and especially magnesium are used for the electrodes and if the gap length is greater than 4 or 5 mm., the frequency can be determined from THOMSON'S equation within a fraction of 1 per cent. for condenser circuits including a spark gap, assuming of course that the values of *L* and *C* are accurately known.⁸

2. THE DAMPING

6. The Transfer of Energy.—*a.* As long as the current, *I*, has the direction of the arrow in Fig. 2, positive electricity is flowing away from the condenser coating *A*, so that the positive charge, + *e*, of this coating is decreasing. When the current is reversed this charge is increasing.

The same applies to the potential difference, *V*, between the condenser coatings, as this and the charge hold the well-known relation:

$$e = CV$$

If curves be plotted showing the variation of *V* and *I* respectively as ordinates with the time as abscissæ, the results will be as in Fig. 14. Voltage and current have a phase displacement of practically 90°.

b. The energy *W_e*, in the electric field of a condenser of capacity *C*, charged to a potential *V*, is known to be

$$W_e = \frac{1}{2}CV^2$$

Similarly the energy *W_m* in the magnetic field of a circuit whose coefficient of self-induction is *L* [9], is known to be

$$W_m = \frac{1}{2}LI^2$$

*Translators' Note: Just these conditions prevail in the modern quenched spark gap.—A. E. S.

where I is the current flowing in the circuit. And the total energy of the field of the condenser circuit at any moment is equal to the sum of the energies of the electric and the magnetic fields, *i.e.*,

$$W = W_e + W_m$$

c. Fig. 15 shows W_e (broken line), W_m (thin full line) and W , the sum of the other two (heavy full line). The current curve, I , from Fig. 14 has also been drawn in again for direct comparison.

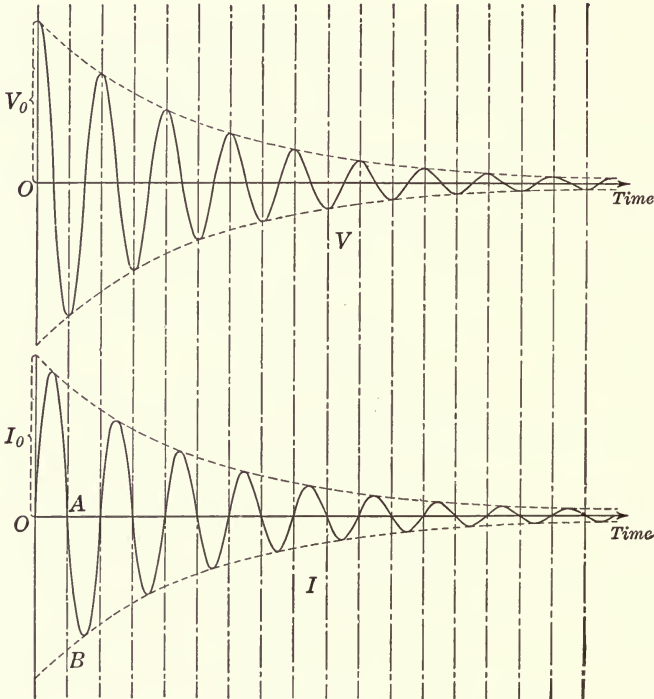

FIG. 14.

At the start when the current is zero, we have

$$W = W_e$$

i.e., the total energy of the circuit consists of the electric energy of the charged condenser.

One-quarter of a period later the voltage is zero (Fig. 14) and the current is just at its maximum. We then have

$$W = W_m$$

or the total energy of the condenser circuit is equal to that of its magnetic field.

After another quarter period the current is zero again and

$$W = W_e, \text{ and so on.}$$

In short, the oscillations are really interchanges of the energy between the electric field of the condenser and the electromagnetic field produced by the current.

7. The Various Causes of Damping.—*a.* If no energy were consumed by this transfer, the total energy W and also the current and voltage amplitudes, in view of the relations explained in Art. 6*b*, would remain constant. Any consumption of energy, however, means a reduction in

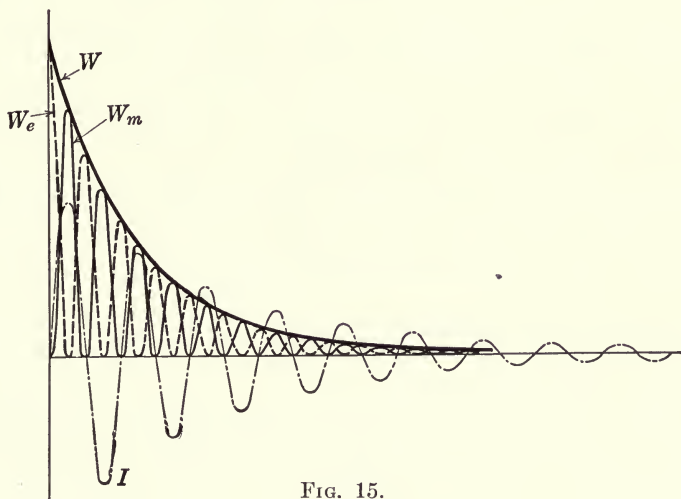

FIG. 15.

the total energy, *i.e.*, a decreasing amplitude, resulting in a “damping” of the oscillations. The question of the various causes of damping is therefore identical with the question of the various energy losses.

b. The energy lost in the oscillations of condenser circuits can be divided as follows: that lost in

1. Heat developed in the metallic circuit.
2. The spark gap.
3. The insulation of the condensers.*
4. “Brush” leakage of the condensers.
5. Eddy currents induced by the alternating magnetic field of the current.†

8. Condenser Circuit without Spark Gap Damping Due to Heat Loss.—*a.* The heat developed by a direct current I in a conductor of resistance r during the time t is

$$rI^2t$$

* And possibly also in the insulation of the coils [Art. 37*c*].

† The energy lost by radiation is extremely small [Art. 25*e*].

while for an alternating current during the time of one cycle T the heat developed is

$$RI_{eff}^2 T$$

where R is the "effective" resistance and I_{eff}^2 is the mean value of I^2 , I_{eff} being the "effective" current. For undamped oscillations, the wave form being sinusoidal,

$$I_{eff}^2 = \frac{1}{2} I_{max}^2$$

(where I_{max} is the maximum amplitude of the current for that cycle) which relation, however, is also practically true of the damped oscillations to be considered in wireless telegraphy. Under these conditions therefore the heat developed per cycle is

$$\frac{1}{2} RI_{max}^2 T$$

From Art. 6b and 6c it follows that the total energy transferred in one cycle (two alternations) is

$$2 \times \frac{1}{2} LI_{max}^2 = LI_{max}^2$$

Hence the energy lost in heat is proportional to the total energy of the oscillations of a condenser circuit.

b. If the energy lost in heat is the only loss, then it can be demonstrated that the curve showing the decrease in the amplitude with time—the "amplitude curve"—is an *exponential* curve. Its characteristic property is the fact that the ratio of the amplitude, A_1 , at the beginning of a cycle to that, A_2 , at the end of the same cycle remains constant during the entire oscillation, *i.e.*,

$$\frac{A_1}{A_2} = \text{const.} \quad (1)$$

The greater this ratio is, the greater is the percentage decrease in amplitude per cycle. Hence the value of this ratio is a measure of the damping. Instead of the ratio itself, however, it is customary to use the natural logarithm of its value:

$$d = \log \text{nat.} \frac{A_1}{A_2} \quad (2)$$

d is called the "logarithmic decrement" or simply "decrement" and where the heat loss is the only cause of damping, as in the preceding, it is distinguished as the "Joulean decrement," d_j .

c. The value of the amplitude A at any time, t , is given by

$$A = A_0 e^{-\frac{d}{T} t} = A_0 e^{-Nd.t} \quad (3)$$

in which N is the frequency, e is the base of the natural logarithms and A_0 is the "initial amplitude" when $t = 0$.*

Fig. 16 shows the decrease in amplitude per cycle for different decrements, while in Table IV the oscillation curves have been drawn out for various decrements.

d. It follows from *a* that the Joulean decrement can be determined from the ratio of the energy lost in one cycle to that transferred in the same cycle. Hence, substituting I_0 for I_{max} , we have

$$d_j = \frac{\frac{1}{2}RI_0^2T}{LI_0^2} = \frac{R}{2L}, \quad T = \frac{R}{2NL} \tag{4}$$

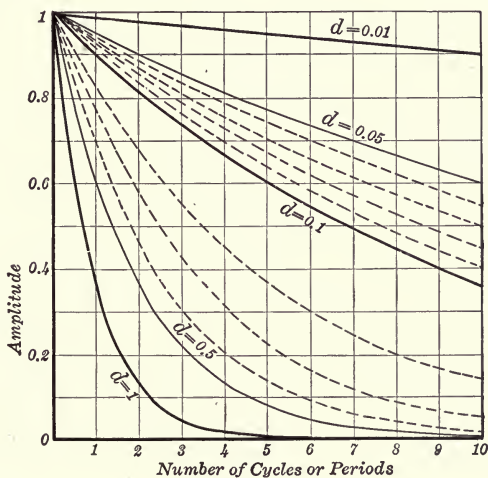

FIG. 16.

or replacing T by $2\pi\sqrt{LC}$ (Art. 3a) we have

$$d_j = \pi R \sqrt{\frac{C}{L}}$$

or from the foot-note in Art. 3a

$$d_j = 2\pi^2 V_L \frac{RC}{\lambda} \dagger$$

9. Condenser Circuit with Spark Gap. Damping due to Spark.—

a. The curves A_1 and A_2 of Fig. 17 are the amplitude curves of condenser circuits containing a spark gap (J. ZENNECK¹⁰) obtained with the Braun Tube, A_1 being for a circuit of very low, A_2 for one with higher ohmic resistance. Comparison with Fig. 16 shows a marked difference from the cases in which the damping is due to heat loss only. The amplitude

* In Fig. 14, V_0 in the upper, I_0 in the lower curve.

† $d_j = 600\pi^2 \cdot \frac{R_{ohms} \cdot C_{MF}}{\lambda_{meters}} = 5920 \frac{R_{ohms} \cdot C_{MF}}{\lambda_{meters}}$ or $= \frac{R_{ohms} \cdot C_{cm}}{150 \cdot \lambda_{meters}}$ approximately.

curve is now no longer an exponential curve but approaches a straight line more and more as the energy absorbed by the spark exceeds the energy lost as heat.¹⁰ This condition is obtained when the spark-gap electrodes are of copper, brass, aluminium or silver,¹¹ while with magnesium electrodes the amplitude curve tends toward the exponential form (D. ROSCHANSKY²).

If the amplitude curve is a straight line the amplitude A at any time t can be obtained from

$$A = A_0 \left(1 - \frac{a}{T} t \right)$$

in which A_0 is the initial amplitude and a is the "lineal decrement" which determines the decrease in amplitude just as d , the logarithmic decrement, does for the exponential curves.

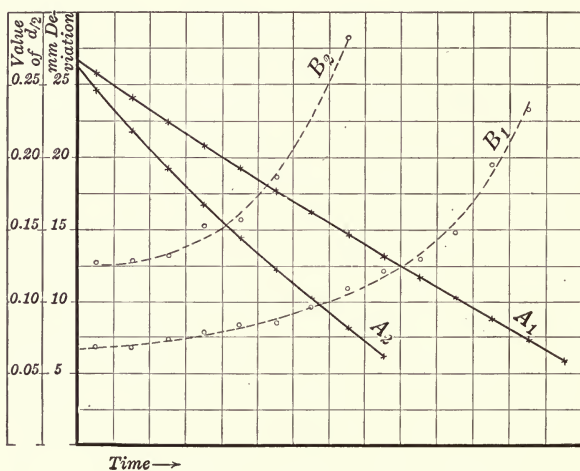

FIG. 17.

b. If the amplitude differs from the exponential form, this is evidence of the fact that the conditions for the absorption of energy in the spark are not the same as for absorption due to ohmic resistance, but are similar to those in an electric arc (A. HEYDWEILLER¹²). For this condition the energy A_0 , absorbed per second in terms of the current is

$$A_0 = aI + b \quad (1)$$

(a and b are constants for the particular spark gap [Table V]) which for larger currents becomes

$$A_0 = aI \quad (2)$$

But since

$$A_0 = IV_0$$

V_0 being the tension across the gap, it follows from (2) that the gap

voltage remains practically constant during the entire series of oscillations,* *i.e.*,

$$V_g = a \quad (3)$$

c. The result is that the ratio of initial to final amplitude of the same cycle or period, $\frac{A_1}{A_2}$, and hence also [Art. 8b] the decrement, do not remain constant for all cycles.† The increase of the decrement is shown by the curves B_1 and B_2 (Fig. 17) for the successive cycles as the amplitudes A_1 and A_2 die out. In short no one definite characteristic decrement exists for the entire series of oscillations.

Nor can a definite resistance be ascribed to the spark gap for those cases in which the energy loss is not proportional to I^2 . If then in practice, an equivalent gap resistance or simply a "gap resistance" R_g is referred to, this is intended to mean that resistance which, if substituted for the gap, would absorb the same amount of energy as is actually absorbed by the spark gap during the entire oscillation series following the same amplitude curve.‡

If the condition $V_g = a$ applies, and we have a straight-line amplitude curve, then

$$R_g = \frac{6a}{\pi I_0} \quad (I_0 \text{ being the initial amplitude}).$$

For the other extreme, when the energy loss in the circuit due to resistance is by far the greater and the curve is exponential we have (H. BARKHAUSEN¹²)

$$R_g = \frac{8a}{\pi I_0}$$

A constant gap resistance R_g would have [Art. 8d] a corresponding "gap decrement"

$$d_g = \pi R_g \sqrt{\frac{C}{L}} \quad (4)$$

so that the total decrement for a condenser circuit with spark gap would be

$$d = d_j + d_g$$

As this value of the decrement is constant for the entire series of oscillations

* This, however, does not hold during a single half period, but is approximately correct if V_g be considered as the average value of the gap voltage for a half period. Even this average value does not remain absolutely constant for the entire train or series of oscillations, but gradually increases from cycle to cycle for copper and silver electrodes and gradually decreases with magnesium electrodes (D. ROSCHANSKY²).

† For the extreme case, in which the energy lost in the gap is the determining factor and the amplitude curve is a straight line, we have the difference of A_1 and A_2 , instead of their ratio, constant.

‡ *i.e.*, $R_g I_{eff}^2$ [Art. 44] is the average energy actually absorbed by the spark gap during 1 second.¹³

tions, it does not properly characterize the decrease in amplitude from cycle to cycle, but is the *average* value of the gradually increasing decrement, its use in practice being very convenient for the qualitative consideration of condenser circuits having a spark gap and corresponding approximately to the single and definite decrement which is a precise and sufficient characterization of the time-decrease of the amplitude for condenser circuits having no gap.

d. Aside from the change in form of the amplitude curve caused by the spark, it has been observed that in a condenser circuit with gap the oscillations may abruptly cease as soon as the amplitude has fallen to a more or less small fraction of the initial amplitude.

10. Methods for Determining the Spark Gap Damping.—Two

methods have in general been used for measuring the gap damping and resistance.

a. The first of these, the so-called *resonance method*, is based on a procedure for determining the total decrement, which will be considered in detail later [Art. 74, etc.].

The total decrement is first measured with and then without the spark gap [Art. 78c]; the difference of the two values obtained is then the gap decrement d_g , from which the gap resistance, R_g [see equation (4) Art. 9] can also be determined.

b. The second¹⁴ is the *substitution method*. In Fig. 18, F is the spark gap

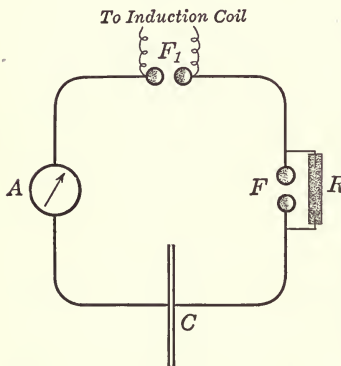

FIG. 18.

whose resistance is to be measured, A is a hot-wire ammeter and R is a very high ohmic resistance (or self-inductance) through which the condenser, C , can be charged in spite of the gap, but sufficiently high so as not to appreciably affect the oscillations passing through F . First the indication of A is noted with F in circuit. Then a variable non-inductive resistance is substituted for F and is adjusted until A has the same indication as before. The spark-gap resistance is then the same as the substituted resistance, if the coefficient of self-induction of the condenser circuit, the discharge frequency and the spark gap F_1 have been held constant in both cases [see Art. 11e, 2].

11. The Factors which Determine the Amount of Gap Damping.¹⁵—

a. Relation to the Current Amplitude.

The gap resistance, other things being equal, and particularly for the same gap length, varies inversely with the current amplitude. Within the limits encountered in wireless telegraph practice the relation

$$R_g \propto \frac{1}{I_0} \quad (1)$$

between gap resistance and current amplitude is approximately accurate.

Assuming that the circuit contains only a single spark gap of constant length, the voltage amplitude must remain constant. If then the current amplitude is varied by changing the coefficient of self-induction of the circuit, then it follows from (1) that

$$R_g \propto \sqrt{L}^{[16]}$$

If, on the other hand, the self-induction is kept constant and the current varied by changing the capacity, we have

$$R_g \propto \frac{1}{\sqrt{C}}^{[16]}$$

Thus an increase in the self-induction of the circuit as in the first case causes an increase in the gap resistance, while an increase in the capacity reduces the gap resistance.

It follows that within the limits for which the relation (1) holds, the spark-gap decrement is practically independent of the capacity and self-induction of the circuit, being determined only by the gap itself.

b. The gap resistance and decrement are however not independent of the resistance of the circuit, both increasing for an increase of the circuit resistance.

c. The effect of the gap itself upon the gap resistance depends upon:

1. The material of the electrodes.
2. The form of the gap, and if the electrodes are spheres, upon the radius of these.
3. The gas or medium through which the spark passes, and
4. The length of the spark.

As to the material of which the electrodes are made, it has been found that copper and silver cause a very high, magnesium, tin and zinc, a very low resistance, while aluminium stands between these groups.

The radius of spherical electrodes, particularly for long sparks, greatly affects the gap decrement; the latter is much smaller with balls of large radius than for small spheres, the gap length being the same throughout. For disc-shaped electrodes the decrement is practically the same as for spheres of very large radius.

If the gap medium is hydrogen, a very high decrement is obtained, it being less with illuminating gas, carbon dioxide, air, oxygen and particularly low for sulphur dioxide.

For the same electrodes, *i.e.*, of a given material and radius and for a given gas in the gap, the decrement becomes larger as the discharge voltage becomes smaller for a gap of constant length; or, again, with constant voltage the gap decrement becomes smaller as the gap is shortened.

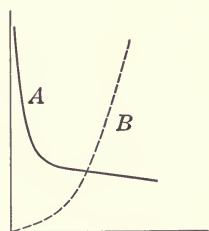

FIG. 19.

d. For the relation between the gap decrement and the gap length the substitution method [Art. 10*b*] gives curves similar to *B** in Fig. 19, if the length *F* in Fig. 18 is varied without changing the rest of the circuit; the increase in gap resistance with increasing length is at first very gradual, then quite rapid. If the gap decrement is determined directly by the resonance method [Art. 10*a*] for different gap lengths, a curve of the form of *A** in Fig. 19 is obtained. Here we have the gap decrement first rapidly and then more slowly, falling off as the gap length is increased. The curve determined by M. WIEN¹⁷ with spherical zinc electrodes is shown in Fig. 20.†

The following explanation accounts for this difference in the results

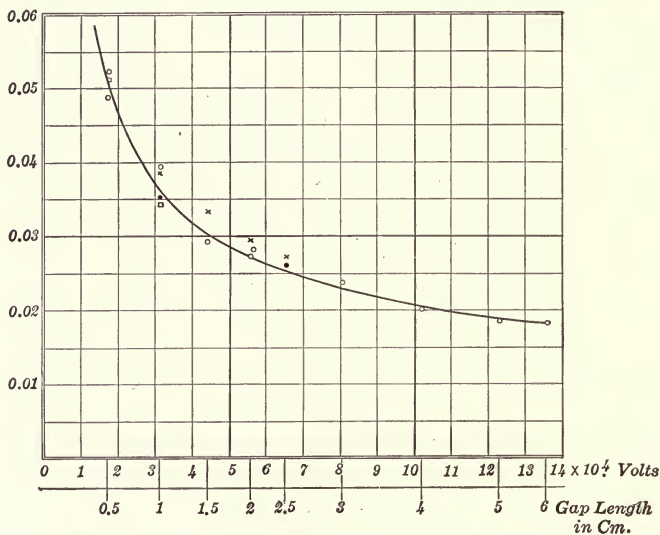

FIG. 20.

obtained. In the resonance method giving curve *A*, the gap under investigation is the only gap in the circuit and its length determines the voltage and current amplitudes. Hence as the gap length is varied the current is correspondingly changed and the gap resistance is determined for a different current amplitude with each observation. An increase in the gap length alone would cause an increase in gap resistance, but an

* Abscissæ \propto gap length, ordinates \propto gap resistance.

† The values given are for the following condenser circuits:

	Radius of Electrodes	<i>C</i>	<i>L</i>
Circles ○	220 mm.	$4.25 \times 10^{-4} MF.$	40,900 C.G.S. Units
Crosses ×	50 mm.	$4.25 \times 10^{-4} MF.$	40,900 C.G.S. Units
Dots ·	50 mm.	$6.3 \times 10^{-4} MF.$	40,500 C.G.S. Units
Circles with dots ○	50 mm.	$5.8 \times 10^{-3} MF.$	40,500 C.G.S. Units
Squares □	50 mm.	$5.8 \times 10^{-3} MF.$	7,300 C.G.S. Units

increased gap length also means increased current amplitude, which latter decreases the gap resistance. We therefore have two factors with opposite tendencies; with short gaps the action of the current amplitude is the more effective of the two, but as the gap becomes longer it is partly compensated by the effect of the greatly increased gap length.

In the substitution method (Fig. 18), current and voltage are determined by the length of the gap F_1 , and therefore practically independent of the gap F , whose resistance is to be measured. Hence as the length of F is varied the current amplitude remains practically *constant*.

In addition there is an essential difference in the nature of the two methods. In the substitution method we find that resistance which, when put in place of the spark gap, produces the same current effect [Art. 43a]. The resonance method gives that value of the resistance

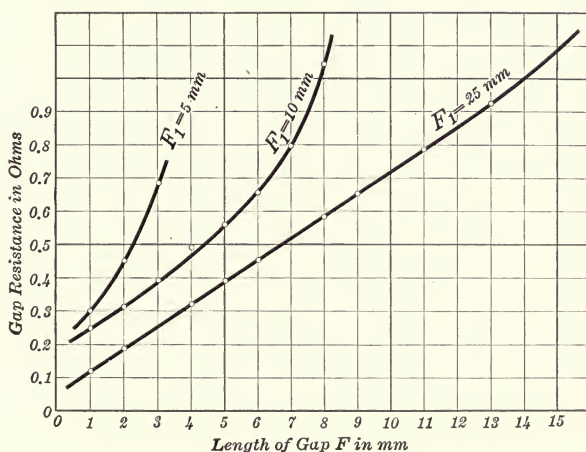

FIG. 21.

which, when replacing the spark gap produces the same degree or rather sharpness of resonance in a loosely coupled secondary circuit [Art. 64c.] These two are not necessarily identical.

e. From *a* and *b* the following conclusions in regard to the *substitution method* may be drawn:

1. The gap resistance of F (Fig. 18) is dependent not only upon its dimensions, the capacity and the self-induction of the circuit, but also upon the length of the gap F_1 (Fig. 18) upon which the current amplitude depends. How great this effect is may be seen from Fig. 21, in which the gap resistance of F is shown for several different lengths of F_1 .¹⁸ Any statement of the resistance of F without an accompanying statement of the dimensions of F_1 is therefore just as useless as stating that the resistance of a metallic filament incandescent lamp is so and so without mentioning the voltage or current at which the measurement was made.

2. Results obtained by the substitution method must not be considered as conclusive in case there is only a single spark gap in the condenser circuit. For when F_1 , having a larger resistance, is in the circuit, this has a considerable effect on the resistance of F . Furthermore the form of the amplitude curve and the conditions in the gap F_1 must be somewhat influenced by placing an ohmic resistance as a substitute for the gap F , so that it does not follow from the fact that the current effect is the same in both cases, that the energy absorbed at F is also the same.¹⁹

12. Spark Gaps in Series (Multiple Gaps).—If a number of spark gaps are connected in series in the same condenser circuit the interesting question arises: Is the decrement for the several gaps in series greater or less than that obtained for a single spark gap with the same *initial voltage*? Investigations²⁰ intended to answer this question have shown that up to potentials of about 80,000 volts and down to capacities as low as 0.6×10^{-3} M.F. the series gap has a higher decrement than the simple gap.

13. Energy Losses in the Dielectric of the Condensers.²¹—The alternating field produced in the insulating material (dielectric) between the coatings of the condensers by the oscillations, involves an energy loss for practically all insulators. It is due to the so-called "dielectric hysteresis" which is the electrical analogue of magnetic hysteresis.

a. Such investigations as have been made so far with various materials indicate that, independently of the frequency of the oscillations, the energy absorbed per cycle in the condenser is proportional to the total energy in the condenser during that period. Hence the "**hysteresis decrement**," d_h , *i.e.*, that portion of the total decrement due to the dielectric hysteresis losses, is independent of the frequency of the oscillations or the dimensions and capacity of the condenser, and is determined solely by the dielectric material, that is by:

1. Its chemical composition,
2. Its temperature.

As to the kind of material, it has been found that the hysteresis decrement is not appreciable for air, very small for well dried paraffin oil and transformer oil ($d_h = 0.001 - 0.002$), also for good flint glass* ($d_h = 0.006 - 0.01$) and somewhat greater for certain grades of hard rubber. It may run very high for certain kinds of glass, *e.g.*, ordinary window glass, other grades of hard rubber, mica and the otherwise very convenient insulating material, micanite.

Increasing the temperature causes an increase in the hysteresis decrement, at times in fact a very considerable increase.

* Can be obtained from Molineaux, Webb & Co., of Manchester (Ancoats, Kirby Str.) and the glassworks at Ehrenfeld near Cologne.

b. With certain materials the hysteresis decrement depends upon the energy load, \overline{W}_e , the relation being of the form

$$d_h = \alpha + \beta \overline{W}_e^*$$

for some materials, and for others

$$d_h = \alpha \overline{W}_e^\beta$$

where α and β are constants for the particular material. In some cases this effect of the energy load is only an indirect one; due to the increased amplitude of the oscillations and the consequent increase in the energy absorbed, a higher temperature is produced, which in turn increases the hysteresis decrement.

14. Energy Lost by Leakage Discharge.—a. For our purposes it is necessary to distinguish between leakage of two kinds. The first of

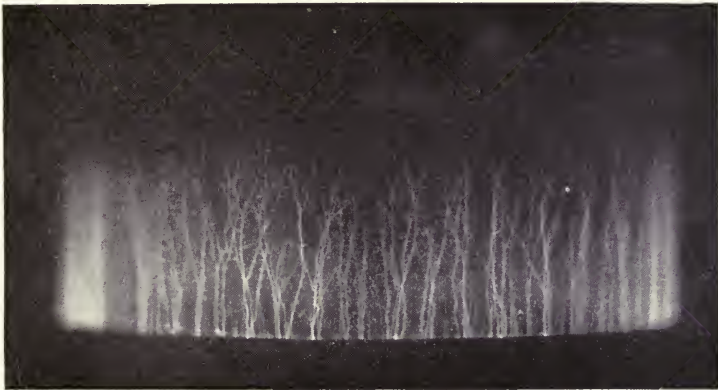

FIG. 22.

these²² occurs whether the conductor is charged by oscillations or has a static charge. It consists of the well-known phenomenon of fine brush discharges emanating from conductors charged to a very high potential, particularly from edges or points. This is due to the fact that under the influence of the strong electric field the air becomes a conductor (ionized) and hence a part of the charge is led off. This phenomenon is observed very frequently on influence machines and occasionally in the air condensers used in wireless telegraphy, wherever the plates have uneven surfaces or along their edges; especially also on antennæ or coils charged to a high potential.

* The "energy load," \overline{W}_e , is the maximum energy contained per cc. of the dielectric material. It is

$$\overline{W}_e = \frac{k}{8\pi} \cdot E_0^2 \cdot \frac{1}{9 \times 10^{20}} \text{ C.G.S.} = 0.443 \cdot k \cdot 10^{-6} E_0^2 \left(\frac{\text{volts}}{\text{cm.}} \right)^2$$

where k = ratio of the dielectric constant of the material to that of air and E = strength of the electric field.

The second kind of leakage discharge occurs only with oscillations; it appears at the moment when the oscillation commences, continuing even if the conducting elements in question do not have their potential increased during the remainder of the oscillation. A leakage discharge of this nature is observed in Leyden jars (see photographic reproduction in Fig. 22) or other condensers having a solid dielectric. It is characterized by long, fine, branching rays which spread out over the surface of the dielectric from the edge of the condenser coatings.

b. The essential requirement for a noticeable leakage discharge in both cases is a sufficient ionization of the air, which in turn means a sufficiently strong electric field. If sharp edges and points, at which the field strength assumes especially great intensities, are avoided as much as possible, these discharges need not be feared, as long as the potential is kept within a few hundred volts.

c. When, however, a discharge as just described, occurs, it means an actual loss of energy in any case. How great this loss may become is not known. But what has been definitely determined is that if Leyden jars are properly constructed the increase in the decrement due to this energy loss can be kept below 0.002 for a voltage amplitude of 30,000 volts, and below 0.007 for 40,000 volts [Art. 86].

In addition it has been found that a discharge of the second kind has a tendency to produce a fluctuation in the frequency [Art. 79].

15. Energy Lost by Eddy Currents.—The alternating magnetic field produced by the oscillations in a condenser circuit induces so-called “**eddy currents**” in all conductors through which the lines of magnetic flux pass. The energy which these currents dissipate in the form of heat, other things being equal, is much greater for the high frequencies used in wireless telegraphy than for the lower frequencies customary in commercial power and lighting circuits. Being a direct loss to the total energy of the condenser circuit, it causes a corresponding increase in the damping.

All conductors in the immediate vicinity of the condenser circuit, particularly those conductors (such as terminals) which are inside of coils where the magnetic field is concentrated, are subject to eddy currents. Very dangerous in this respect are the coatings of condensers which, in view of their extensive surface and thinness,* may cause considerable eddy current losses. Leyden jars are very troublesome on this account; with plate condensers it is much easier to place the coatings in such a position as to minimize the magnetic flux cut by them.

Care should be taken in using such artificial insulating materials as are frequently substituted for hard rubber or marble, if placed in a strong high frequency magnetic field. The conductivity of such substances may be great enough to cause considerable energy losses.²³

* Very thick masses of metal are less dangerous.

16. Relative Importance of the Various Energy Losses.—*a. Condenser Circuits with Spark Gap.*—The important question here is: Which energy losses come into consideration as compared to the energy dissipated in the spark?

If the conductors of the circuit are copper wires or tubes of sufficient diameter, it is safe to conclude that the Joulean (heat) decrement will be entirely negligible as compared to the spark gap decrement.

Eddy current losses may become very considerable if provoked by clumsy connections or arrangements, particularly with the condensers. With proper care, however, these losses may also be so reduced as to have no material effect on the total decrement.

In view of the high potentials for which condenser circuits with spark gaps are usually designed, a dielectric of high insulating quality is essential. If, then, compressed air condensers [Art. 39*b*] or condensers filled with a good oil are used, the hysteresis decrement becomes negligible as compared to the gap decrement. The hysteresis losses in good flint glass are also much smaller than in the spark gap. As soon as other dielectrics are tried, however, losses comparable to or even greater than those occurring in the spark gap must be anticipated, especially if the condensers are to be highly charged.

The energy lost by leakage discharge in condensers can, by careful design, be reduced to a quantity negligible in comparison to the gap losses. In any case this loss is, in general, far less important than that caused by the frequency fluctuations [Art. 86].

b. Condenser circuits without a spark gap are usually designed for comparatively low voltages. For that case, losses due to leakage discharges usually disappear. Furthermore, as air condensers—even at atmospheric pressure—can generally be used, losses due to dielectric hysteresis can be entirely avoided. If, however, such potentials as may be encountered do produce leakage discharges, the losses may be far greater than those due to Joulean heat.

The latter may be greatly reduced by the use of sufficiently thick and massive copper wires or, better yet, copper bands or strips, and especially by properly wound braided wire consisting of individually insulated conductors [Art. 36*d*]. This, however, tends to increase the eddy current losses, and if these losses are not minimized by the greatest care, it is not possible to bring the decrement below 0.01. In fact, decrements of about 0.003 are the very lowest attained in practice.

CHAPTER II²⁴

OPEN OSCILLATORS

In a condenser circuit, the condenser itself offers the only break in the continuity of the circuit. It is therefore usually referred to as a “closed oscillator” or “closed oscillating circuit,” as distinct from systems in which the metallic conductor is not even approximately continuous and which are therefore “open oscillators.”

1. THE LINEAL OSCILLATOR

17. **The Fundamental and Upper Harmonic Oscillations.**—The simplest form of open oscillator is the straight lineal oscillator, *i.e.*, a straight metal wire or rod. If its two halves are given a positive and a negative charge respectively until a sufficiently high potential is reached, so that a spark discharge passes between the two halves (at

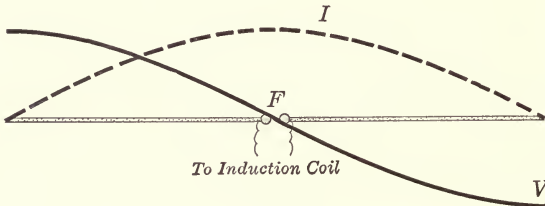

FIG. 23.

F, Fig. 23), an electromagnetic oscillation takes place here just as in a condenser circuit.*

In general this oscillation is not a simple one, but is made up of a number of component oscillations of different frequencies, different current and voltage distributions and different electric and magnetic fields. It will therefore be necessary to consider separately the so-called “**fundamental oscillation**”—that having the lowest frequency, as in acoustics—and its “upper harmonics” or “**upper partial oscillations.**” This subdivision in the treatment is further justified by the fact that each of these oscillations can be produced independently of the others.

18. **Current and Potential Distribution in the Fundamental Oscillation.**—*a.* In a condenser circuit, as used in practice, the quantity of

* The natural oscillation can be induced in open oscillators as well as in condenser circuits without the existence of a spark gap in the oscillator [Art. 109].

electricity passing through a cross-section of the circuit in a certain length of time, just as in ordinary direct-current circuits, is practically the same at all points,* *i.e.*, the current† has the same phase and amplitude throughout the entire circuit. We can therefore speak of a definite phase and amplitude of the current just as for the alternating currents used in power and lighting circuits.

In a lineal oscillator the current† may also be considered as having the same phase at all parts of the oscillator. But *the current amplitude is entirely different at different parts of the oscillator*. If a curve be plotted

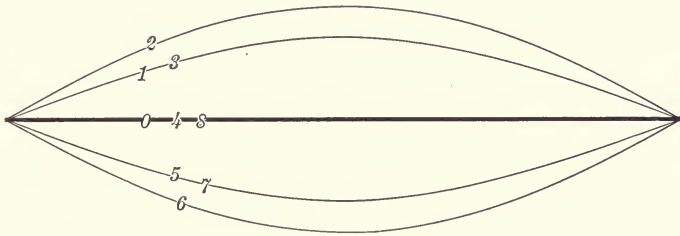

FIG. 24.

giving the current amplitude at each point of the oscillator as ordinates, this “**curve of current distribution**”‡ is found to be an approximate sine curve (dotted line in Fig. 23). The current amplitude is greatest at the middle and zero at the ends of the oscillator. In other words, there are “**current nodes**” at each end and a “**current anti-node**” at the middle.

b. Correspondingly, if we plot the electric charge or rather the potential values along the length of the oscillator, we obtain the

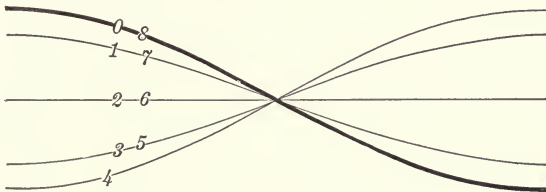

FIG. 25.

“**curve of potential distribution**” as shown in Fig. 23 by the full line (sinusoidal) V . It should be noted that “**potential**” or “**voltage anti-nodes**” occur at each end of the oscillator, the “**potential node**” being at the middle.

* Hence called a “*quasi-stationary current.*” Compare footnote in Art. 24c.

† The current = quantity of electricity passing through a cross-section of the circuit in 1 second.

‡ This should not be confused with the “current curve” of Art. 1b, which gives the variation with time.

c. Just as in a condenser circuit, and for the same reasons, the current and voltage in an open oscillator have a 90° phase displacement. The distribution curves of the current and the voltage are shown in Figs. 24 and 25 respectively for successive eighths of a cycle, curves bearing the same number in the two figures being for the same instant.

19. Frequency of the Fundamental Oscillation.—The simplest way to arrive at the fundamental frequency is by the following consideration:

a. The current and potential distribution curves of Fig. 23 are of the same type as the so-called “stationary waves” encountered in other physical phenomena (as in acoustics). Such stationary waves result when two advancing waves of the same amplitude and frequency but of opposite direction occur simultaneously. The wave-length of the stationary wave is then the same as that of the advancing waves, if by wave-length of the stationary wave we understand twice the distance between two consecutive nodes or anti-nodes.

As is well known, the “wave-length,” λ , of an advancing wave is equal to the distance traveled by the wave in one complete cycle. The **propagation velocity**, V_L , is the distance traveled in 1 second. If the duration of a cycle or period is T seconds, then $1/T$ or N complete cycles occur per second. Hence we have the relation

$$V_L = N\lambda = \frac{\lambda}{T} \quad (1)$$

b. As we are justified in considering the oscillations of a lineal oscillator, as shown in Fig. 23, as stationary waves, we can apply equation (1), writing it in the form

$$N = \frac{V_L}{\lambda} \quad (2)$$

N being the frequency.

From *a* and as shown in Fig. 23, *one-half the wave-length* is equal to the *total length, l , of the oscillator, i.e.,*

$$\frac{\lambda}{2} = l \quad (3)$$

c. The velocity of propagation of the electromagnetic waves occurring in air along a conductor²⁵ is practically equal to the velocity of light in air, hence:

$$V_L = 3 \times 10^{10} \text{ cm./sec.}$$

whence:

$$N = \frac{3 \times 10^{10} \text{ cm./sec.}}{2l_{(cm.)}} \quad (4)$$

This simple relation if not quite accurate is approximately correct.*

* This and what follows is based on the assumption that the oscillator is in free space, *i.e.*, for practical consideration, its distance from conductors or high insulation must be large in comparison to its own dimensions.

20. The Electromagnetic Field of the Fundamental Oscillation.—

a. *Direction of the Electromagnetic Field.*—The magnetic field is comparatively simple, the lines of induction being circles whose axes coincide

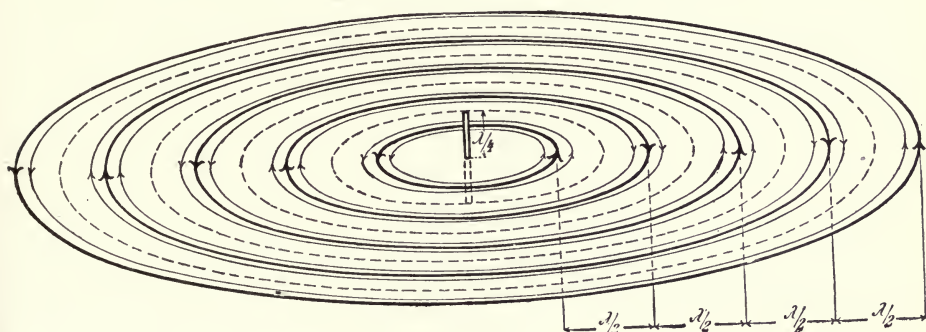
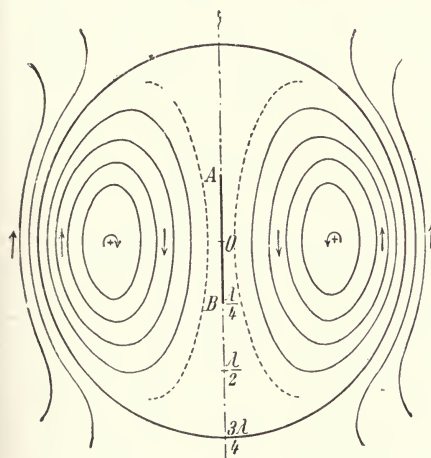

FIG. 26.

with the axis of the oscillator. Fig. 26* shows the lines of induction in the equatorial plane† at a given instant.

The lines of force of the electric field are shown in Figs. 27 to 30, for undamped oscillations‡ at each eighth period during one-half a cycle



t = 0
FIG. 27.

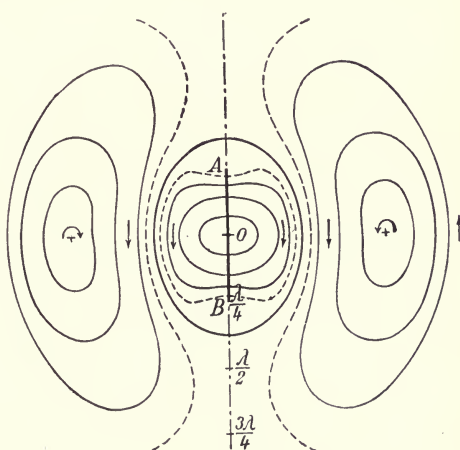

t = $\frac{1}{8}T$
FIG. 28.

as calculated by M. ABRAHAM²⁶ and drawn by F. HACK²⁶. Fig. 27 represents the moment at which the charge of the oscillator is zero, while

* This and the following figures do not indicate the falling in amplitude with distance [c, d].

† That is, the plane perpendicular to the oscillator at its middle.

‡ For damped oscillations the nature of the phenomenon would not be noticeably different.²⁷

the current is a maximum; the following figures show conditions at each successive eighth period until after Fig. 30, Fig. 27 would again apply but with opposite signs, and so on.

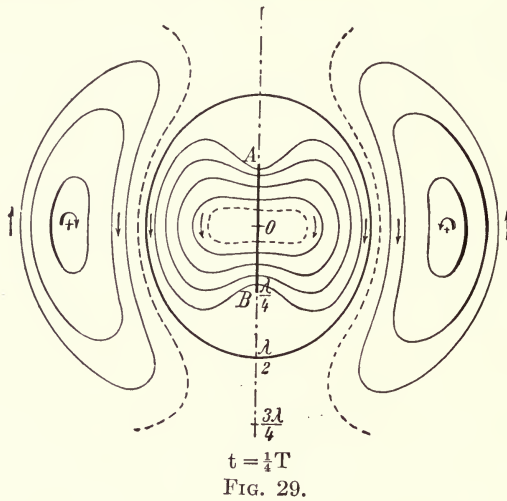

To better comprehend these figures consider first that at the moment of zero charge, as in Fig. 27, no lines of force emanate from the oscillator. Immediately thereafter, however, the oscillator becomes charged, for

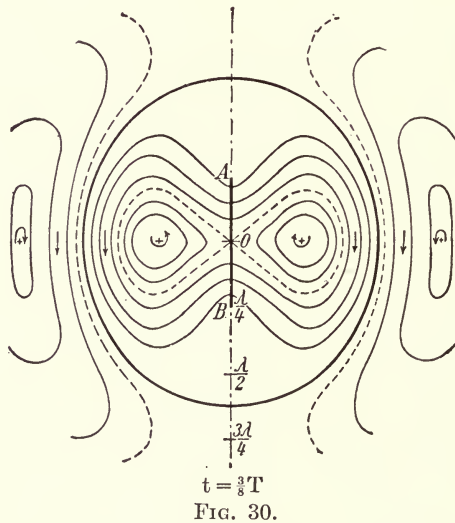

example as in Fig. 28, the upper half positively, the lower part negatively, and lines of force emanating from the upper half reenter in the lower half. This process continues cumulatively until the maximum charge

is reached at the end of the quarter period (Fig. 29). Then the lines of force in the oscillator gradually decrease again until zero is reached after half a period. A part of the lines of force which have emanated from the oscillator (Fig. 30) during the first quarter period go through a peculiar contraction during the second quarter, assuming a kidney-like shape, and at the same time continue to move farther away from the oscillator. What happens to them as they pass off into distance is shown in Figs. 295 and 296, the first representing conditions at the moment of maximum charge, the second at zero charge. The advancing lines of force gradually become arcs of circles.

b. Phase of the Electromagnetic Field. Advancing Waves.—Neither the magnetic nor the electric field has the same phase at any moment throughout the entire space affected. Both assume the form of a wave advancing out from the oscillator with the velocity of light.

The following will explain what is understood by an advancing electromagnetic wave, in the simplest case, when the amplitude remains constant. If over each point of the line of direction (OX in Fig. 31)

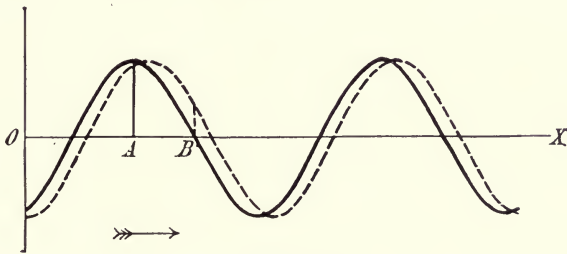

FIG. 31.

of the advancing wave we were to plot as ordinates the field intensity at any given moment, a sine curve, such as the full line curve in Fig. 31, would result. It represents the distribution of the field strength along OX at this moment. A moment later a similar sine curve is obtained, but slightly displaced from the first one in the direction of the advancing wave front (as shown by the arrow). This is indicated in Fig. 31 by the dotted line curve. Hence a conception of the process may be formed by considering the sine curve to move in the direction of and with the velocity of the advancing wave, its position at any instant indicating the distribution of the field intensity at that moment.

From the preceding, it follows that at any one point there exists a simple alternating field whose frequency is

$$N = \frac{V_L}{\lambda}$$

in which λ is the wave-length of the advancing wave and V_L its velocity, in this case the velocity of light.

It is evident that the phase varies from point to point.* It is the same, however, for two points lying in the direction of the advancing wave and separated by the distance of one wave-length, or a multiple thereof. If the two points are just a half wave-length apart, the phase difference will be 180° . Or, in general, we have the phase difference is $\frac{2\pi x}{\lambda} = \frac{360^\circ x}{\lambda}$ where x is the distance between the two points.

Similarly, if x is the difference in the respective distances of two points in the equatorial plane from the oscillator, the phase difference between the fields at these points is also $\frac{2\pi x}{\lambda}$.

c. The Amplitude of the Field.—Neither the amplitude of the magnetic nor that of the electric wave remains constant for different distances, r , from the oscillator; the amplitudes decrease as r increases. The magnetic wave amplitude in the immediate proximity of the oscillator roughly $\propto 1/r^2$, and at very great distances $\dagger \propto 1/r$; the electric field amplitude also $\propto 1/r$ at very great distances, but close to the oscillator it approximately $\propto 1/r^3$.

For the same distance, r , from the oscillator, the amplitude is greatest



FIG. 32.

for points in the equatorial plane; for any points outside of this plane, it decreases as the distance from the equatorial plane becomes greater.

d. The Field at Great Distances from the Oscillator.—The electric as well as the magnetic waves approach a spherical shape (see Figs. 295 and 296) as the distance from the oscillator becomes very great; hence small portions of the wave front may be regarded as plane waves. In the immediate vicinity of the equatorial plane the lines of both electric and magnetic flux may be regarded as straight lines, the *electric flux lines being perpendicular, the magnetic lines parallel to the equatorial plane* (Fig. 32).

The *electric and magnetic fields are "in phase"* \ddagger if they are considered to be of positive value in the directions shown by the arrows in Fig. 32.

* For instance, at *A* the oscillation shown by the full line curve (Fig. 31) is at that instant at its maximum, whereas a moment later, as shown by the dotted curve, it has already decreased. At *B*, on the other hand, there is an increase between these two instants.

\dagger *i.e.*, the distance from the oscillator is "great" or "small" in relation to the wave-length.

\ddagger In fact synchronism of the electric and magnetic fields exists at all great distances from the oscillator whether in or outside of the equatorial plane.

If E_0 and M_0 are the amplitudes of the electric and magnetic fields respectively, in the equatorial plane or its immediate vicinity, then [see Art. 25c]

$$E_0 = 2V_L \frac{|I_0|}{r}$$

$$M_0 = 2 \frac{|I_0|}{r}$$

in which $|I_0|$ is the current amplitude at the "current anti-node" of the oscillator.

21. Damping of the Fundamental Oscillation.—*a.* Just as in the case of condenser circuits, there is a transfer and re-transfer of energy between the electric and magnetic fields in the oscillations of lineal oscillators. There is, however, one very important difference. In a condenser circuit only such energy as is in some way changed into heat (due to the circuit resistance or in the dielectric of the condenser) is lost. But in a lineal oscillator, as shown in Fig. 28 and following figures, a portion of the electromagnetic field together with the energy it possesses becomes severed from the oscillator and passes off into space. The energy thus passed off is therefore lost to the oscillator. The amount of energy sent out per second in this way is called the "radiation," Σ .

b. This dissipation of energy must of course affect the damping of the oscillation, so that to the other decrements there is added a "radiation decrement" (also called the "HERTZ decrement").

According to M. ABRAHAM,²⁶ the radiation decrement of a lineal oscillator is given by

$$d_\Sigma = \frac{2.44}{\log \text{nat} \frac{l}{r}}$$

(l being the length, r the radius of the oscillator). For a length of 100 meters, d_Σ has the following values for different diameters of wire:

Diam. of Wire in mm.	d_Σ
0.5	0.18
1	0.20
2	0.21
3	0.22
4	0.225
5	0.23

Hence for all wires within these limits the radiation decrement is not far from 0.2.

c. In general, the radiation decrement is much greater than the Joulean decrement, assuming the oscillator to consist of copper wire of at least 1 to 2 mm. diam. The radiation decrement is therefore the

determining factor in open oscillators which have no spark gap and no heavy leakage discharge.

If the oscillator contains a spark gap, the gap decrement may assume considerable proportions, just as in condenser circuits. The energy loss due to leakage (see Art. 14a), has not been carefully investigated as yet, though it has been found at times to be quite appreciable as compared with the other losses.

22. Upper Harmonics of the Lineal Oscillator.—*a.* The distribution of current and potential is shown for the first 3 harmonics in Figs. 33, 34 and 35. The dotted lines marked *I* are for the current, the full lines, *V*, for the potential.

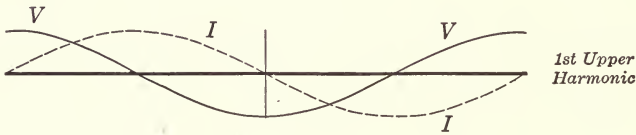

FIG. 33.

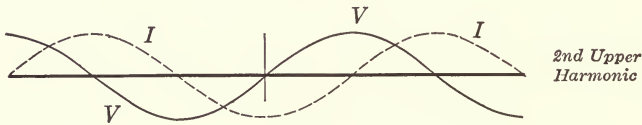

FIG. 34.

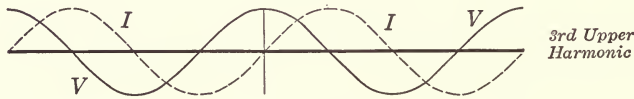

FIG. 35.

b. As these upper harmonics may properly be considered as stationary waves as well as the fundamental oscillation, we have the following equations for wave-length and frequency:

$$\text{Fundamental: } \frac{\lambda}{2} = l; N = \frac{3 \times 10^{10}}{2l_{cm.}} \cdot \frac{1}{\text{sec.}}$$

$$\text{First Upper Harmonic: } \frac{\lambda_1}{2} = \frac{l}{2}; N_1 = \frac{3 \times 10^{10}}{l_{cm.}} \cdot \frac{1}{\text{sec.}}$$

$$\text{Second Upper Harmonic: } \frac{\lambda_2}{2} = \frac{l}{3}; N_2 = 3 \cdot \frac{3 \times 10^{10}}{2l_{cm.}} \cdot \frac{1}{\text{sec.}}$$

Hence the frequencies of the upper harmonics are simple multiples of the fundamental frequency.

c. The conditions for the *electromagnetic field* are similar to those of the fundamental oscillation. Here especially we have a portion of the electric lines of force separating and passing off into space.²⁶ This also results in a continued radiation of energy with the consequent radiation damping.

23. Coils.²⁸—In the first place it is very probable that natural oscillations of the kind described in Art. 17, *et seq.*, can occur in a wire even if it is wound in a cylindrical coil instead of being stretched out in a straight line.

a. The *current and potential distribution* for the fundamental and upper harmonic oscillations is qualitatively the same as for straight wires: the fundamental wave has a current anti-node and a potential node at the center of the coil and current nodes with potential anti-nodes at either end, while the first upper harmonic has current nodes and potential anti-nodes both at the middle and at the ends. Quantitatively, however, the relations differ in several respects from those of straight wires.

b. Comparing the frequency of the fundamental oscillation of a coil of wire with that of a lineal oscillator of the same length of wire, we have the following: With long, narrow coils the frequency may be as much as one and one-half times as great as for the straight oscillator of the same wire length and the wave length correspondingly only two-thirds that of the straight wire. For short, wide coils, however, the frequency is always less* (the wave-length always greater) than for a straight oscillator of the same wire length; in fact the coil frequency may be very much lower (the wave-length very much greater).

Hence the frequency of the fundamental oscillation† of a coil is not directly proportional to its wire length, as for straight oscillators, and must be determined experimentally, unless the frequency can be determined by the methods already described.²⁸

c. A characteristic difference between relatively long thin coils and the straight lineal oscillator is in their effective capacity [Art. 27], which is much smaller for a long thin coil than for a straight wire of the same length. As a result, with such coils a very slight change in the capacity has a very marked effect on the frequency. A small piece of metal, in fact even of insulating material, brought near the ends of the coil is sufficient to produce a noticeable change in the frequency (“*capacity-sensitiveness*” of coils).

d. A further characteristic difference lies in the *extremely low radiation of coils* as compared to straight lineal oscillators. Hence radiation plays but a very slight part in the damping of coils, so that as long as there is no leakage discharge the damping of coils is determined almost entirely by the Joulean decrement. For coils without a spark gap, whose wires are massive but neither extremely thick nor thin, the decrement is of about the same order of magnitude as for a condenser circuit with spark gap. By the use of flat copper strip or of braids whose strands are individually insulated [Art. 36*d*] and by proper design of the coils, the

* If the coil length is about twice its diameter, then the wave-length is approximately the same as for the straight wire oscillator, *i.e.*, it is twice the wire length.

† And also of the upper harmonics.

decrement can be brought just as low as for condenser circuits without a spark gap.²⁹

No systematic investigations have as yet been made as to just how the decrement of coils is affected by *leakage discharge*. Such observations as have been made, however, indicate that the effect is quite marked.³⁰

2. GENERAL PROPERTIES OF OPEN OSCILLATORS

24. Current and Potential Distribution Along a Wire.—Consider a portion of an oscillator of any kind and any frequency to consist of a straight or at least not extremely bent (*e.g.*, wound in coil form) wire. Then the following holds approximately true for the distribution of current and potential along the wire:³⁰

a. The curve of current distribution is a part of the sine curve representing the current distribution of a straight lineal oscillator of the same frequency [Art. 18]. The same applies to the potential curve.

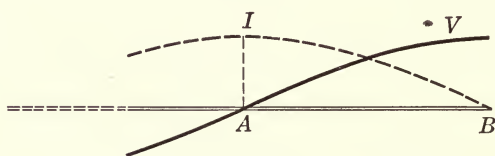

FIG. 36.

That is, in accordance with Art. 19, the current and potential curves for the wire are parts of sine curves, whose nodes (or anti-nodes) have a distance apart (which is a half wave-length) as given by the relation

$$\frac{\lambda}{2} = \frac{V_L}{2N} \quad (1)$$

in which N is the frequency of the oscillator.

b. Just as for the straight lineal oscillator (Figs. 23, 33, 34, 35), the current anti-nodes coincide with potential nodes and *vice versa*. The relation between the current amplitude $|I_0|$ at the current anti-node to that of the potential $|V_0|$ at its anti-node depends mainly upon the dimensions of the wire. We have

$$\frac{|I_0|}{|V_0|} = \sqrt{\frac{C^{(1)}}{L^{(1)}}} \quad (2)$$

in which $C^{(1)}$ and $L^{(1)}$ indicate the capacity and coefficient of self-induction respectively of the length of wire considered as a unit.

c. Whether any nodes and anti-nodes of current and potential exist at all on the wire, and if so, at what points, depends on the shape of the entire oscillator and the nature of its oscillations. If one end of the wire

is free, there must necessarily be a current node (potential anti-node) at that end, as the current must be constantly zero at this point.

Thus if B in Fig. 36 is the free end of a wire oscillator, the current and potential distribution must be about as shown in the figure. Here the portion $AB =$ one-fourth of the wave-length according to equation (1).

If the oscillator consists of two symmetrical halves, the fundamental oscillation must have its current anti-node (potential node) at the center of the oscillator.*

25. The Electromagnetic Field at Great Distances from the Oscillator.

—*a.* Consider the straight wire oscillator AB , shown in Fig. 37, to have a length l , very short in comparison to the wave-length of the oscillation,† so that the current amplitude is practically the same at all points of the wire. Then the relations determining the electromagnetic waves radiated by such an oscillator become very simple, if we limit ourselves to distances, r , from the wire which are very great as compared to the wave-length.



FIG. 37.

It should be noted that the relations which follow are quite different from those which apply to static fields. We have then:

1. At any point, P (whose distance r from AB is much greater than the wave-length) the *direction* of the electric field lies in the plane containing P and the wire AB . In Fig. 37 this is the plane of the page. It is perpendicular to the radius r . The magnetic flux M is perpendicular to the plane of the page at P .

2. The respective *amplitudes* of the electric and magnetic fields are:

$$\left. \begin{aligned} E_0 &= \pi \cdot V_L \cdot \frac{l}{\lambda} \cdot \frac{I_0}{r} \sin \vartheta = 2\pi N \cdot l \sin \vartheta \frac{I_0}{r} \text{ C.G.S.} \\ M_0 &= \pi \cdot \frac{l}{\lambda} \cdot \frac{I_0}{r} \sin \vartheta = 2\pi N \cdot l \sin \vartheta \frac{I_0}{r} \cdot \frac{1}{3 \times 10^{10}} \text{ C.G.S.} \end{aligned} \right\} \quad (1)$$

* For example, this would apply to a condenser circuit as shown in Fig. 1, in which the current node occurs at F . From what has been said it follows that the statement [Art. 18*a*] that the current amplitude is the same at all points of a condenser circuit holds true only as long as the length of the circuit is very small as compared to $\frac{\lambda}{2}$. To be sure, this is probably always the case for condensers as used in practice.

† This can be accomplished by placing bodies of relatively large capacity at the ends A and B [Art. 28].

That is, the field strength is proportional to the current amplitude, I_0 , the frequency, N , of the oscillation and to the projection, $A'B'$, of the wire length, l , on a line perpendicular to r ($A'B' = l \sin \vartheta$ in Fig. 37).

3. The **phase** of the electric and of the magnetic fields is the same.* The difference in phase with the current depends on the distance r .³³ It increases as for all advancing waves [Art. 20b], proportionally to r ; if r is increased by an amount x , the phase difference increases by $\frac{2\pi x}{\lambda}$. Hence the oscillations at two points at respective distances r_1 and r_2 may be considered as having the same phase only if $r_1 - r_2$ is very small as compared to λ .

b. The results stated above may be used for calculating the *electromagnetic field of any oscillator* at any point, P , whose distance from the oscillator is great compared to the wave-length.³⁴ The correct value of the field can be obtained by applying the following rule: Consider the oscillator subdivided into small elements l_1, l_2 , etc., sufficiently short to have the current amplitudes (I_{10}, I_{20} , etc.), constant throughout each length. Then calculate the field strength for each element from equation (1), given in *a*. The partial fields so obtained are then combined, giving the total resultant field.†

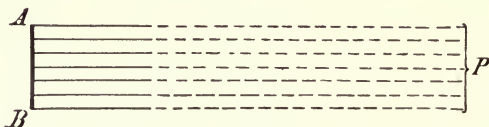

FIG. 38.

c. This method becomes very simple if the oscillator is unidirectional (AB in Fig. 38) and if the field is to be calculated for a very distant point in or very close to the equatorial plane.

We then have the angle ϑ [a] = 90° for all the current elements, so that the individual partial fields have the same direction. Also the distance r of the different current elements is practically the same and hence the partial fields all have the same phase. Hence, under these conditions the amplitude of the resultant field equals the sum of the amplitudes of the partial fields, *i.e.*,

$$\left. \begin{aligned} E_0 &= \frac{2\pi V_L}{\lambda} \cdot \frac{1}{r} (l_1 I_{10} + l_2 I_{20} + \dots) \\ M_0 &= \frac{2\pi}{\lambda} \cdot \frac{1}{r} (l_1 I_{10} + l_2 I_{20} + \dots) \end{aligned} \right\} \quad (2)$$

* Assuming that E and M are considered positive in the directions of the arrows in Fig. 37.

† Allowance must be made not only for the difference in direction of the partial fields, but also for their phase differences.

The factor $(l_1 I_{1_0} + l_2 I_{2_0} + \dots)$ means the sum of the products of the length and the corresponding current amplitude of each element.

This result may be expressed in various ways:

1. The summation factor in parentheses is nothing other than the product of the oscillator length and the *average value*, \bar{I}_0 ,³⁵ of the current amplitude in the oscillator equation (2) may therefore also be written:

$$\left. \begin{aligned} E_0 &= 2\pi V_L \frac{l}{\lambda} \cdot \frac{\bar{I}_0}{r} = 2\pi N \cdot l \cdot \frac{\bar{I}_0}{r} \\ M_0 &= 2\pi \frac{l}{\lambda} \cdot \frac{\bar{I}_0}{r} = \frac{2\pi}{V_L} N \cdot l \cdot \frac{\bar{I}_0}{r} \end{aligned} \right\} \quad (3)$$

2. As the average value of the current amplitude along the entire length of the oscillator can not be measured directly, it is more con-

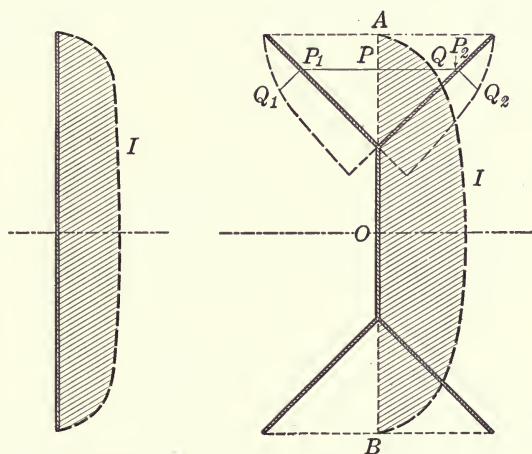

FIG. 39.

FIG. 40.

venient to introduce the maximum current amplitude $|I_0|$ at the anti-node. For the given current distribution \bar{I}_0 is proportional to $|I_0|$, i.e.,

$$\bar{I}_0 = \alpha |I_0|$$

The factor α , which is determined by the nature of the current distribution, is called the **“form factor”** of the oscillator.

If the current amplitude is the same at all points along the oscillator [Art. 28] $\alpha = 1$, which of course is its maximum value. As the other extreme, we have the case of the current distribution curve on each half of the oscillator being practically a straight line passing through the end of the oscillator [Art. 31a]; here $\alpha = 1/2$.³⁶ If the current distribution curve is a pure sine curve as in Fig. 23, then $\alpha = 2/\pi$.^{*37}

* This value of α substituted in equation (4) page 38 gives the equations in Art. 20d, remembering that $l = \lambda/2$ [Art. 19b].

Introducing the form factor into equations (3), we obtain:

$$\left. \begin{aligned}
 E_0 &= 2\pi V_L \cdot \frac{\alpha l}{\lambda} \cdot \frac{|I_0|}{r} = 2\pi \frac{\alpha l}{\lambda} \cdot \frac{|I_0|}{r} 3 \times 10^{10} \text{ C.G.S.} \\
 &= 60\pi \frac{\alpha l}{r} \cdot \frac{|I_0|_{amp}}{r_{cm}} \cdot \frac{\text{volts}}{\text{cm}} = 2\pi N \cdot \alpha l \cdot \frac{|I_0|}{r} \\
 M_0 &= 2\pi \frac{\alpha l}{\lambda} \cdot \frac{|I_0|}{r} = \frac{2\pi N}{3 \times 10^{10}} \cdot \alpha l \cdot \frac{|I_0|}{r} \text{ C.G.S.}
 \end{aligned} \right\} \quad (4)$$

3. Interpreting this geometrically, if we plot the curve of current distribution by plotting the current values as ordinates at each current element and connecting the points thus obtained (dotted curve in Fig. 39*), then the area (shaded in Fig. 39) included by this curve and the oscillator = ($l_1 I_{10} + l_2 I_{20} + \dots$). Hence it follows from equation (2) that *the area included by this curve is a measure of the amplitude of the electromagnetic field in distant parts of the equatorial plane.* That is, the current distribution field curve is also characteristic of the effect at remote distances.

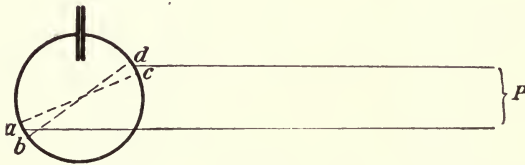

FIG. 41.

d. This construction can easily be applied to *more complicated oscillators* (e.g., of the form shown in Fig. 40†) in which the individual current elements have different directions. A straight line, *AB*, is drawn through the middle point, *O*, of the oscillator, perpendicular to the equatorial plane. At each point, *P*, of this line ordinates, *PQ*, are erected equal to the sum of the current amplitudes of all the points (current elements) of the oscillator which lie in the plane containing *P* and parallel to the equatorial plane. Thus at *P* in Fig. 40 we have $PQ = P_1Q_1 + P_2Q_2$.

The area (shaded in Fig. 40) between the curves (dotted in Fig. 40) thus obtained and the straight line *AB* is proportional to the amplitude of the electromagnetic field at very distant points in the equatorial plane.‡

* The curve of Fig. 39 has been purposely chosen of arbitrary form; it would be a sine curve for a straight lineal oscillator.

† Oscillator consisting of simple straight wire at the center with two branched wires at each end.

‡ However, this construction is justified only if the width of the oscillator is very small as compared to the wave-length. In that case the justification of this construction follows from *b* and *c*.

e. If the procedure given in *b* is applied to a *closed oscillator*, *e.g.*, to the simplest form of condenser circuit (Fig. 41), whose dimensions are very small as compared to the wave-length of the oscillation, it is found that this oscillator does not give a powerful field at distant points as, say, at *P*. The partial fields of the individual current elements (*e.g.*, those of *ab* and *cd*, Fig. 41) practically neutralize each other.

Much the same is true of coils.

26. The Radiation of an Oscillator.—In Art. 25 it was shown how to determine the amplitude of the electric and magnetic field at distant points in the equatorial plane of any oscillator. The amplitude of this electromagnetic field is to a certain extent a measure of the energy radiated by the oscillator.

a. Imagine a sphere whose center is that of the oscillator and whose radius is very large compared to the wave-length; then the amount of energy passing through 1 sq. cm. of the surface of the sphere during each cycle or period is

$$\frac{1}{8\pi} E_0 M_0 T$$

E_0 and M_0 representing the amplitude of the electric and magnetic fields respectively at the point in question.^{37a}

If the amplitude at all points were as great as in the equatorial plane, then the quantity of energy passing through the total surface F of the sphere, per cycle, which is also the total radiation per cycle, would be

$$\frac{1}{8\pi} |E_0| |M_0| \cdot T \cdot F$$

in which $|E_0|$ and $|M_0|$ represent the field amplitude in the equatorial plane. As a matter of fact, however, the field strength decreases from the equator to the poles, and the actual total radiation per cycle is

$$\frac{\gamma}{8\pi} |E_0| |M_0| \cdot T \cdot F$$

the factor γ being less than unity and depending upon the nature of the decrease of the field strength from the equator to the poles. While this factor varies with different types of oscillators, the variation is so small as to be negligible for qualitative considerations.* From the foregoing, we may therefore conclude: *The greater the amplitude of the electric and magnetic fields at distant points in the equatorial plane, the greater is the radiation of the oscillator.*†

b. According to Art. 25 both E_0 and M_0 are proportional to $|I_0|$.

* For sinusoidal current distribution $\gamma = 0.61$, while for even distribution, *i.e.*, the same current amplitude at all points along the oscillator, $\gamma = 0.67$.³⁸

† The amplitude of the electromagnetic field in the vicinity of the oscillator is absolutely no indication of the amount of radiation.

Hence the energy radiated per cycle varies as $|I_0|^2 \times T$ and the energy radiated per second, that is, the radiation, Σ [see Art. 21a], is proportional to $|I|_{eff}^2$, if $|I|_{eff}^2$ is the average time value of $|I|^2$. Hence we may write the energy radiated per second

$$\Sigma = R_{\Sigma} \cdot |I|_{eff}^2 \quad (1)$$

The expression for the energy lost by radiation thus arrived at is entirely analogous to that for the energy lost as heat developed by the resistance of the circuit ($= R|I|_{eff}^2$ [Art. 27a]). In view of this analogy R_{Σ} is called the “**radiation resistance**” of the oscillator.

From this definition and from the relations explained in Art. 25, it follows that $R_{\Sigma} \propto l^2 \propto N^2$ or $1/\lambda^2$. Approximately (R. RÜDENBERG³⁹) we have:

$$\begin{aligned} R_{\Sigma} &= \frac{8\pi^2 V_L}{3} \cdot \left(\frac{\alpha l}{\lambda}\right)^2 = \frac{8\pi^2}{3} \cdot \left(\frac{\alpha l}{\lambda}\right)^2 3 \times 10^{10} \text{ C.G.S.} \\ &= 80\pi^2 \left(\frac{\alpha l}{\lambda}\right)^2 \text{ ohms [see Table XIII]} \end{aligned} \quad (2)$$

At one limit (same current amplitude throughout the entire oscillator) $\alpha = 1$ [Art. 25c], and

$$R_{\Sigma} = 80\pi^2 \left(\frac{l}{\lambda}\right)^2 \text{ ohms} = \text{approx. } 800 \left(\frac{l}{\lambda}\right)^2 \text{ ohms}$$

while for the other limiting case $\alpha = 0.5$ and

$$R_{\Sigma} = 20\pi^2 \left(\frac{l}{\lambda}\right)^2 \text{ ohms} = \text{approx. } 200 \left(\frac{l}{\lambda}\right)^2 \text{ ohms.}$$

For the case of sinusoidal current distribution of the form shown in Fig. 23 ($\alpha = 2/\pi$, $l = \lambda/2$) equation (2) gives $R_{\Sigma} = 80$ ohms. Actually, however, as shown by a more accurate calculation²⁶ the radiation resistance in this case is

$$R_{\Sigma} = 73.2 \text{ ohms.}$$

27. Effective Capacity and Effective Self-induction of an Oscillator.—

a. It is frequently convenient to express the frequency, N , the wavelength, λ , and the Joulean decrement, d_j , of an oscillator similarly to the expressions for a condenser circuit, viz.,

$$N = \frac{1}{2\pi\sqrt{LC}}; \quad y = 2\pi V_L \sqrt{LC} \quad (1)$$

$$d_j = \frac{R}{2NL} = \pi R \sqrt{\frac{C}{L}} = 2\pi^2 V_L \frac{RC}{\lambda} \quad (2)$$

* Or [Art. 8d].

$$d_j = 600\pi^2 \frac{R_{\text{ohms}} C_{MF}}{\lambda_{\text{meters}}} = \text{approx. } \frac{2}{300} \frac{R_{\text{ohms}} C_{cm}}{\lambda_{\text{meters}}}$$

The quantities designated herein by R , L and C are called the “effective resistance,” “effective coefficient of self-induction” and “effective capacity” respectively.

R may be defined as being that value in the expression $R|I|_{eff}^2$ when this is equal to the energy dissipated as (Joulean) heat per second,⁴⁰ if $|I|$ is the current at that point of the oscillator at which the maximum current amplitude occurs.* L and C are then defined by equations (1) and (2).

From this definition of R it follows that R —the same being true also of L and C —depends not only on the dimensions of the oscillator, but also on the frequency and on the resulting *distribution of current and potential*. For example, these quantities will have different values for the fundamental and for the upper harmonic oscillations.

If $|V_0|$ is the maximum potential amplitude occurring at any point of the oscillator, and if $|I_0|$ is the maximum current amplitude, then we have

$$|I_0| = \beta \cdot \omega C |V_0| = \beta \cdot \sqrt{\frac{C}{L}} \cdot |V_0|$$

in which β is a factor whose value for the majority of cases encountered in practice differs only slightly from 1.

b. Just as the Joulean decrement is determined by the ohmic resistance, so the radiation decrement d_z may be expressed in terms of the radiation resistance:

$$d_z = \frac{R_z}{2NL} = \pi R_z \sqrt{\frac{C}{L}} = 2\pi^2 V_L \frac{R_z C \dagger}{\lambda} \quad (3)$$

3. VARIOUS FORMS OF COMPLEX OSCILLATORS

28. Lineal Oscillator with Two Equal Capacities, One at Each End (Hertz Oscillator).—*a.* The effective capacity of the oscillator is increased by the conductors‡ attached at the ends. Hence the frequency will be lower and the wave-length greater than for a simple wire of the same length. The difference is the greater as the end capacities are greater in proportion to effective wire capacity.

b. The distribution of current and potential must be as shown in Fig. 42.§ The greater the attached end capacities are as compared to

* Generally this is the current value at the anti-node.

† Or [Art. 8d]

$$d_z = 600\pi^2 \frac{R_{\Sigma ohms} C_{MF}}{\lambda_{meters}} = \text{approx. } \frac{2}{300} \frac{R_{\Sigma ohms} C_{cm.}}{\lambda_{meters}}$$

‡ It is assumed that the conductors mentioned here and in what follows have dimensions so small in comparison to the wave-length that the potential may be considered as the same at all parts of the conductor. This is largely, though not entirely true of spheres, circular or rectangular sheets of metal or wire meshes.

§ In regard to shaded portion of this and following figures, see Art. 33.

the effective wire capacity, the nearer does the minimum current amplitude at any point of the wire approach the current amplitude at the anti-node, *i.e.*, the curve of current distribution approaches a straight line parallel to the oscillator, and the form factor approaches 1.0 in value.

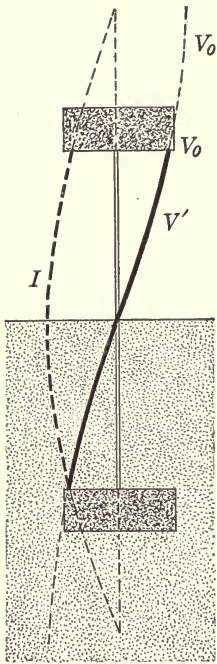

FIG. 42.

The current amplitude at its anti-node is determined by the potential amplitude at its anti-node from equation (2) Art. 24. As a matter of fact the highest potential on the oscillator occurs at the end capacities. Hence the current amplitude is much greater in relation to the maximum potential amplitude than it would be for a simple wire of the same length.

c. If we compare such an oscillator, as regards effectiveness at a distance, with a lineal oscillator of the same length, the former (HERTZ transmitter) has the advantage of its high current value at the current anti-node and the high value of its form factor [Art. 25c]. On the other hand, from equation (2) Art. 25 the longer wave-length of the HERTZ oscillator would be unfavorable. However,⁴¹ in spite of this latter condition, the effectiveness at a distance of a HERTZ oscillator is greater than that of a

lineal oscillator of the same wire length, assuming that the maximum potential amplitude is the same on both oscillators.

29. Lineal Oscillator with Capacity at One End.—

a. Current and potential distribution are shown in Figs. 43 and 44, for a moderate capacity in Fig. 43, for a very large* capacity in Fig. 44. The larger* the capacity attached at one end is, the greater is the wave-length of the oscillation and the farther from the middle of the wire does the current anti-node (and node of potential) occur, coming nearer to the end capacity.

If the attached end capacity is extremely great as compared to the effective capacity of the wire, then the current anti-node (also the node of potential) is but very slightly displaced from the end capacity; hence the wire length is about equal to one-quarter of the wave-length (Fig. 44).

b. The following will explain why the potential node and current

* In comparison to the effective wire capacity.

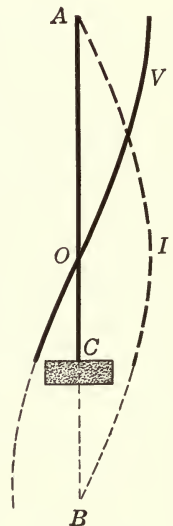

FIG. 43.

anti-node must necessarily occur at the capacity in the last-mentioned case. The relation between potential, V_0 , and current, I_0 , amplitudes at any point is given by

$$I_0 = \omega CV_0$$

Hence if the capacity, C , of the attached conductor is very large, V_0 must be very small for a given value of I_0 .* It follows that, if a conductor of very great capacity is attached to an oscillator at any point, a node of potential and a current anti-node will occur at or very near to this point. If a potential node (current anti-node) already existed at this point, the addition of capacity will not change the distribution of current and potential from the previous condition.

c. The conditions indicated in Figs. 43 and 44 may also be conceived in a somewhat different way. Given the portion OA in Fig. 43 and the current and potential distribution along OA . This distribution can be obtained by the addition of a symmetrical portion, OB , forming a straight lineal oscillator. However, the portion OB can be replaced by a shorter portion, OC , and a capacity C , so chosen that the current and potential distribution on OA as well as the frequency remain just the same as for the symmetrical oscillator AOB . The shorter OC is in relation to OA , the greater must be the capacity C .

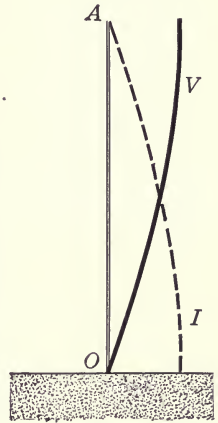

FIG. 44.

30. Lineal Oscillator Containing Series Condensers.⁴²—*a.* Assume two condensers of the same size inserted one at each side of, and at a distance a from the middle point of a lineal oscillator. We may then, with sufficient accuracy, conceive the condenser capacities and the effective capacity of the wire as being simply connected in series. As a matter of fact the introduction of the condensers does reduce the effective capacity of the oscillator. The result is an increase in frequency and thereby a *shortening of the wave length*, which is the more marked the smaller the introduced capacity is in proportion to the effective capacity of the wire.

The distribution of current and potential must be approximately as shown in Fig. 45. This follows partly from the effect of the frequency upon current and potential distribution discussed in Art. 24, partly from the relation between the current amplitude I_0 at the condenser of capacity C and that of the potential, $V_1 - V_2$, between the condenser coverings, viz.,

$$I_0 = \omega C(V_1 - V_2)_0$$

* $\omega (= 2\pi N)$ does *not* become very small at the same time.

b. If the two condensers are brought nearer together at the center of the oscillator until they may be replaced by a single condenser, the current and potential distribution will be as shown in Fig. 46.

c. If the inserted condenser or condensers have very great capacity, as compared to the effective capacity of the wire, their introduction has no appreciable effect upon the characteristics of the oscillation, independently of the point at which the condensers are added.

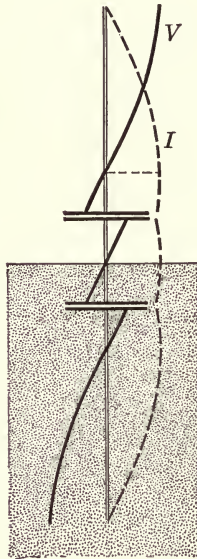

FIG. 45.

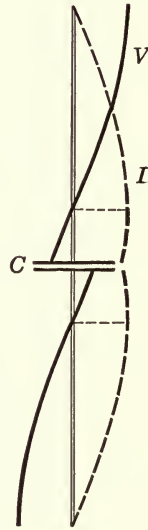

FIG. 46.

31. Lineal Oscillator Containing Series Inductance.⁴²—*a.* The introduction of coils increases the effective coefficient of self-induction of the oscillator. The result is reduced frequency with increased wave-length. The extent of the change depends upon the dimensions of the coil as compared to those of the rest of the oscillator. For a given oscillator the coefficient of self-induction of the coil is a good measure for the change in wave-length:* the greater the coefficient of self-induction of the coil is, the greater will be the change in wave-length caused by its introduction.

The distribution of potential and current must be as shown in Fig. 47, assuming that the length $AC = \frac{1}{4}$ wave-length. Only that portion of the current curve which is near the current node lies on the wire. Hence the average current amplitude is comparatively low and also the maximum current amplitude occurring on the oscillator is much less than it would be for a straight lineal oscillator corresponding to the same potential amplitude.

* At least for such cases as are encountered in practice.

The greater the self-induction of the inserted coil, the greater will be the wave-length of the oscillations as compared to the length of the oscillator and the more will the curve of current distribution on each half of the oscillator approach a straight line passing through the end of the oscillator, the form factor α approaching $\frac{1}{2}$ in value.

b. The coil adds nothing appreciable to the distance effect [Art. 25e]; the current distribution along the straight part of the oscillator, with its low form factor is very unfavorable for distance effect, while the increase in wave-length due to the coil has the same unfavorable tendency. All these factors tend jointly to considerably reduce the distance effect, as well as the radiation resistance of such an oscillator, as against a straight lineal oscillator of the same length and potential.

Moreover, as the effective capacity of an oscillator of the form shown in Fig. 47 is practically the same as that of a lineal oscillator of the same length, while the effective coefficient of self-induction is much greater, it follows, from equation (3) Art. 27, that the *radiation decrement* is *much smaller* for an oscillator containing a series coil than for a straight oscillator of the same length.

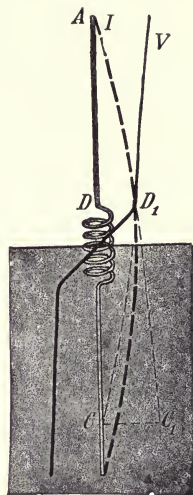

FIG. 47.

32. Lineal Oscillator with Both Inductance and Capacity.—a. The decrease in frequency caused by the introduction of coils can be either entirely or partly compensated for by the introduction of condensers, or converted into an increase in frequency [Art. 30].

Just which of these three possibilities will result depends upon the relative values of the self-induction and the capacity, other things being equal. If the coils have the greater effect, the distribution of current and potential will be similar to that shown in Fig. 47, while if the condenser effect is the greater, the distribution will be as shown in Fig. 45 or 46.



FIG. 48.

If the effect upon the frequency of the coils is exactly compensated for by that of the condensers, then the current and potential distribution along the straight portion of the oscillator (Fig. 48) is about the same as for an ordinary straight oscillator of the same length.

b. In one respect, however, the oscillator of Fig. 48* differs very materially from a simple straight oscillator of the same length, viz., the *radiation decrement* of the former is much

* The reader must imagine a symmetrical lower half for Fig. 48.

less than for the latter as obtained from the relations given in Art. 26 and 27*b*. Hence oscillators of the form shown in Fig. 48 are frequently referred to as "**oscillators with reduced radiation damping.**"

33. Grounded Oscillators.—It was shown in Art. 29 that one-half a straight lineal oscillator may be replaced by a capacity connected* at the center (current anti-node) without noticeably changing the distribution of current and potential for the fundamental oscillation of the remaining half of the oscillator. This is by no means restricted to the plain lineal transmitter, but holds equally good for any of the classes of oscillator discussed in the preceding paragraphs.

The earth may, within certain limits, be considered as such a large capacity on condition that it is *highly conductive* at the point in question. If then, in the oscillators previously described, we assume a half of each removed and the remaining half directly connected to a conductive portion of the earth, *i.e.*, "**grounded,**" the current and potential distribution in each case will remain unchanged. The distribution curves of Figs. 42 to 48 therefore are also correct if only the upper half of each oscillator remains and the lower half, shown in the shaded area, is replaced by a "good ground." Moreover, what has been stated in the preceding in regard to the *frequency* and *wave-length* of the fundamental oscillation of symmetrical oscillators holds equally true for the grounded half.

* *i.e.*, directly connected by actual contact, not by any means through a wire connection of any material length.

CHAPTER III

THE HIGH FREQUENCY ALTERNATING-CURRENT CIRCUIT

1. RESISTANCE, SELF-INDUCTION AND CAPACITY

34. Current Distribution in Cross-section of Solid Wires.—For direct currents and also approximately for alternating currents of such frequencies as are used for commercial power and lighting purposes, the current per unit area is the same at all parts of the cross-section of the conductor. But with the high frequencies customarily employed in wireless telegraphy, the current density is always greatest in the parts nearest the surface of the wire. It decreases as the center of the wire is approached, the decrease being most rapid for higher frequency, higher conductivity and higher permeability of the material of the wire. This

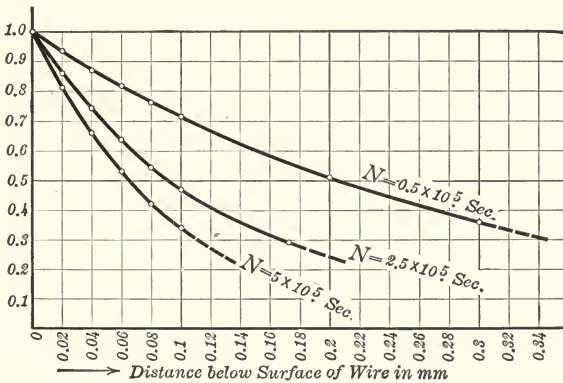

FIG. 49.

decrease may be so rapid that practically the entire current is restricted to a very thin outer sheath of the wire (the so-called “skin effect”).

Fig. 49* shows the drop in current density in copper wire as the depth from the surface is increased, for various frequencies.

35. Coefficient of Self-induction.⁴⁴—If the skin effect is very decided, there is practically no magnetic field within the wire. While for direct currents the coefficient of self-induction of the circuit is made up of two parts, one originating from the field inside of the wire, the other from the

* The minimum wire radius for which the curves of Fig. 49 still hold good, at $N = 0.5 \times 10^5$ /sec., is about 3 mm.; at $N = 2.5 \times 10^5$ /sec., about 1.6 mm.; and at $N = 5.0 \times 10^5$ /sec., about 1.1 mm. With thinner wires, the drop in current density is not so rapid.

field without the wire, for high frequency alternating currents the first part (which for non-ferromagnetic straight wires of length l cm. amounts to $\frac{l}{2}$ C.G.S. units) practically disappears. No great error will be made if for straight or nearly straight solid wires the first part is neglected and the "effective coefficient of self-induction," L , for high frequencies is calculated by deducting $\frac{l}{2}$ C.G.S. units from the value applying to direct currents (see Table VI). For wires which are much bent, however, the relations are not so simple* (see Art. 37).

If the development of a skin effect is prevented by the use of properly woven and twisted braid, consisting of individually insulated wires [Art. 36*d*], the effective coefficient of self-induction, L , for oscillating currents will not differ materially from that, L_s , for direct current, this being true not only of straight wire circuits, but also of coils wound in a single layer.⁴⁵

36. Resistance of Straight Wires.—A further result of the uneven distribution of the current is that the cross-section of the thin outer sheath, in which the flow of current is concentrated, rather than the section of the entire wire, determines its resistance to high frequency currents. In fact the so-called "effective" resistance, R , of a wire also called the **alternating-current resistance** for high frequency oscillations [Art. 8*a*], is something quite different from the resistance for direct current. This difference increases as the frequency, the radius of the wire, its conductivity and its permeability become greater.⁴⁶

a. Table VII at the end of the book gives the resistance of copper wires of various sizes and for different frequencies encountered in radio practice. The resistance of iron wire is much higher on account of high permeability so that for this reason alone its use in practice is forbidden.

b. For very thin wires, particularly when made of metal having low conductivity, the effective resistance at radio frequencies is but little different from that for direct current, the difference decreasing as the size of wire decreases. In Table VIII are given those sizes of wire of different material and at different frequencies for which this variation from the direct-current resistance is just 1 per cent.

Resistances⁴⁷ which are practically non-inductive and practically independent of the frequency can be made up of thin wires of constantan, manganin and nickelin for small currents, while braids of these wires individually insulated, arc lamp carbons, graphite rods and also glass tubes containing an electrolyte, such as CuSO_4 solution, serve for larger currents.

* The coefficient of self-induction of coils made of heavy wire may be about 20 per cent. less for high frequency oscillations than for direct current.⁴⁵ Formulæ for the coefficient of self-induction, L , of coils are given in Table VI.

c. The following conditions are closely associated with the skin effect:

1. A copper tube with walls not extremely thin has, to all intents and purposes, the same resistance as a solid wire of the same diameter and material (*i.e.*, of course, for high frequency currents).

2. Tinned copper wire is not desirable, as the current is carried mostly by the poorly conducting tin, making the resistance higher than for the untinned wire.

3. Copper-clad steel wires have a resistance only very little higher than copper wires, and combine the high conductivity of the copper with the greater tensile strength of the steel, which is very advantageous for antennæ submitted to high wind stresses.*

d. An important difference between the resistance for direct currents and that for high frequency currents lies in the relation to the wire radius, r , for in the first case the resistance $\propto \frac{1}{r^2}$, while in the latter case (for wires not too thin) it $\propto \frac{1}{r}$.

In other words the direct-current resistance simply depends on the total cross-section of the conductor, whether this is a single wire or made up of a number of wires in parallel giving the same total cross-section.

For oscillating currents it is preferable to replace heavy solid wires or tubes by *braids of very thin individually insulated wires* or flat bands made up of such braids woven together.† But care must be taken that the current does not distribute itself much the same as it would in a solid wire, *i.e.*, mainly in those of the smaller wires lying near the outer surface. This is provided for by so twisting and interweaving the component wires that each of them lies at the outside just as many times as on the inside of the circuit, resulting in a uniform current amplitude in all the wires.

Furthermore, while for direct currents the resistance, aside from the specific conductivity of the material, depends only on the *area* of the cross-section, the *form* of the section also plays a part in determining the effective resistance of a conductor carrying high frequency oscillations, *e.g.*, thin copper bands⁴⁹ in general have a lower resistance than cylindrical copper wire of the same cross-sectional area, though the resistance of the bands also increases rapidly with increasing frequency unless they are exceedingly thin.

* For example, the antenna of the Eiffel Tower has galvanized steel wires.

† The first suggestion to use woven ropes of thin insulated wires for high frequency circuits probably originated with N. TESLA.⁵⁰ F. DOLEZALEK was the first to introduce them into actual practice. Braided wire of this kind is furnished by many manufacturers, but by no means always of equal value. Braids of enameled wire (*i.e.*, wire having very thin enamel insulation) of 0.07 mm. diam. are very satisfactory.

37. The Resistance of Coils.⁴⁵—The only conductors having appreciable self-induction encountered in radio circuits are usually in the form of either “cylindrical coils” (Figs. 50 and 51) or “flat spirals” (Figs. 52, 53 and 54; see also the much used form in Fig. 236 marked “28”).

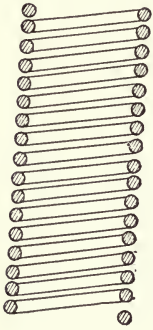

FIG. 50.

a. If these coils are made of solid wire the current distribution over the cross-section is subjected to a further complication as compared to the simple straight solid wire. The current amplitude is no longer distributed symmetrically to the wire's axis but is considerably greater on the inner side of the coil than on the outer side. This results in a further increase of the resistance, so that the effective resistance of coils as

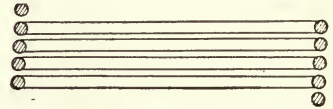

FIG. 51.

used in radio work is apt to run as high as one and one-half to two times that of the same wire when unbent.

The dissipation of energy and hence the effective resistance of coils is considerably increased if they are so constructed that a large propor-

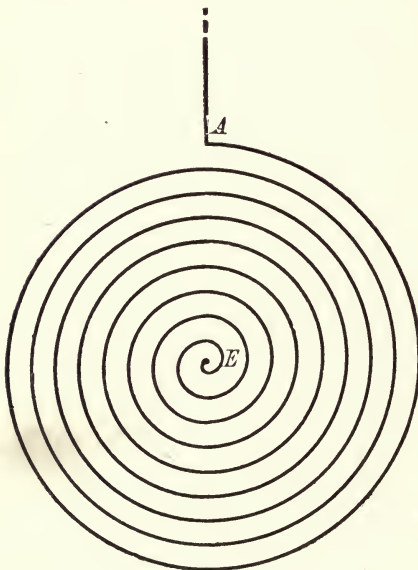

FIG. 52.

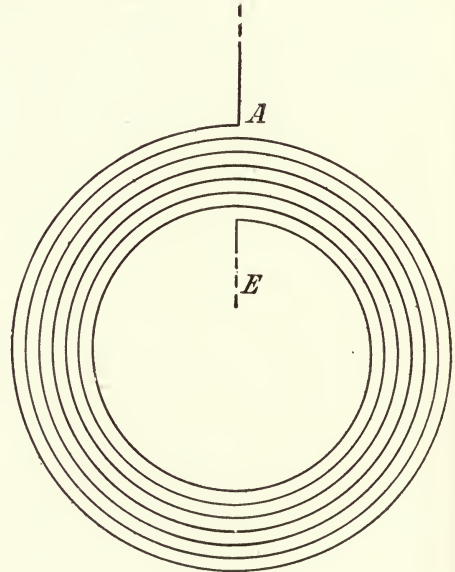

FIG. 53.

tion of the magnetic force cuts the turns of the wire (as for example at the ends of the coil).

In this case, however, the effective resistance may often be reduced by the use of a wide copper strip or band in place of wire having a

circular section, or better yet, conductors made up of small, individually insulated twisted wires (or braids or bands woven out of such conductors), the thinness of the individual wires, the method of twisting and interweaving them and the form of the coil determining the resultant effective resistance.

b. With coils wound in several layers a further loss due to dielectric

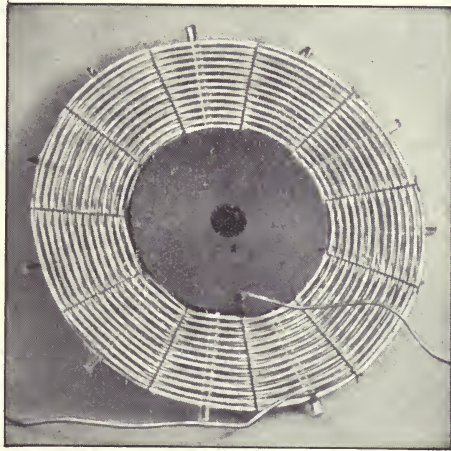

FIG. 54.

hysteresis may be added. With alternating current a relatively high difference of potential exists between adjacent layers, causing a correspondingly intense alternating electric field which may result in energy losses in the insulating material affected. For this reason and also because they otherwise tend to increase the energy losses, coils wound in several layers are not generally desirable.

38. Coils having Variable Self-induction.⁵²—*a.* Changes of the self-induction in large steps are most easily attained by varying the number of turns connected in circuit, say through the use of plug or clip contacts; thus in Fig. 55 the current enters through *A* and leaves the coil either at *B* or *C* or *D*.

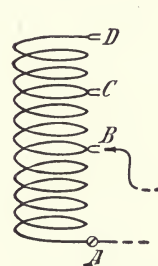

FIG. 55.

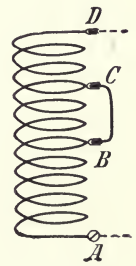

FIG. 56.

If the plug contact is at *B*, then the portion *BD* together with parts of the current circuit may constitute an oscillator which is directly coupled [Art. 52*b*] with the current circuit; the oscillations of this system may at times produce undesirable disturbances. Furthermore, losses may result from eddy currents induced in the free portion (*BD*) through which flows the magnetic flux generated in the connected portion (*AB*). It is

therefore advisable to so choose coils that the free end, BD , does not become too long.

Under no circumstances should the variation of the self-induction be obtained by short-circuiting a number of the turns (e.g., BC , Fig. 56). Heavy currents would be induced in the short-circuited portion, causing a large energy loss.

b. Self-induction variations in small steps may be obtained by the use of sliding con-

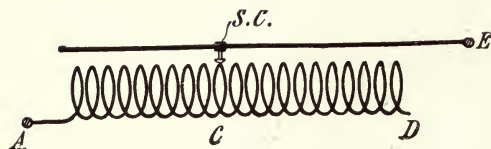

FIG. 57.

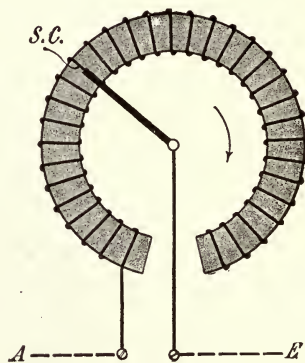

FIG. 58.

tacts. Fig. 57 shows this method as applied to a cylindrical coil and Fig. 58 to a modification of this, the "ring coil." The latter has the advantage of enclosing practically all its lines of magnetic force, thereby minimizing eddy current losses in neighboring conductors and disturbances in near-by circuits. The ring coil, however, involves greater construction difficulties.

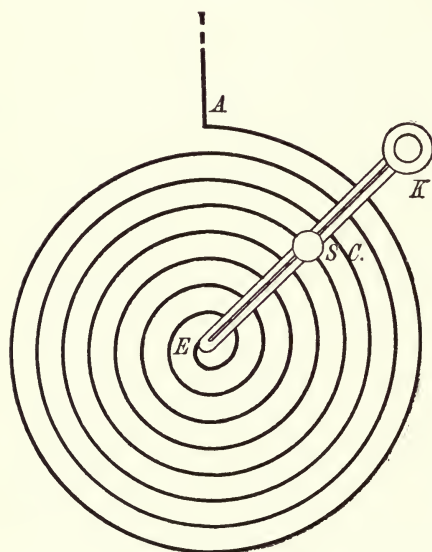

FIG. 59.

Care must be taken with coils of the form of Figs. 57 and 58 that the sliding contact provides good conductivity and that it does not touch more than one wire at the same time, thereby short-circuiting the turn included between them.

c. A uniformly gradual change of the self-induction is attainable in a particularly simple manner with flat coils (Fig. 59) which are provided with a rotating arm, K , and a movable sliding contact, SC , for this purpose.

Cylindrical coils may also be so arranged, in that the coil is rotated about its axis, the turning causing

a sliding contact to move up and down along its length as in the *Kohlrausch* bridge or by having the wire of the coil, which is bare and flexible, wound and unwound to any desired extent on a bare metallic cylinder or roll, as in the *Wheatstone* resistances.

The arrangement used most widely for gradual variation of the self-induction (called "variometer" in radio practice) consists of two coils connected either in series or in parallel and whose relative position to

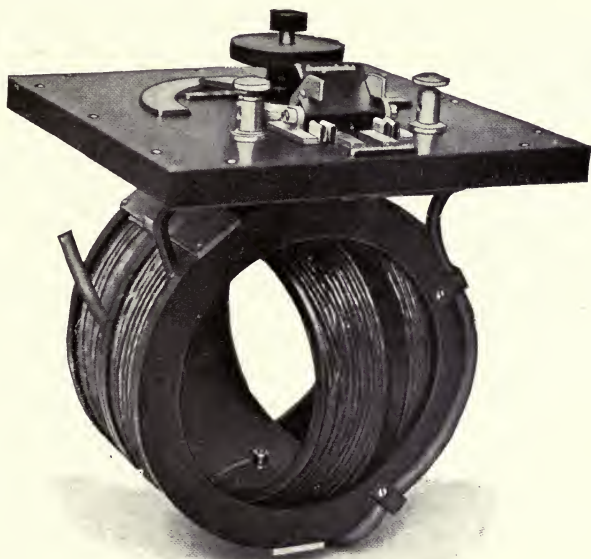

FIG. 60.

each other may be varied. Fig. 60 shows a variometer designed by G. SEIBT and C. LORENZ, in which one of the coils is turned around inside of the other. The self-induction of these is a maximum when the two coils stand parallel to each other and the current flows through both in the same

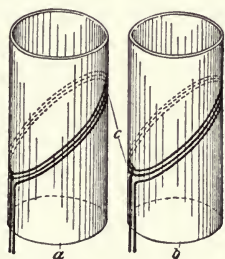

FIG. 61.

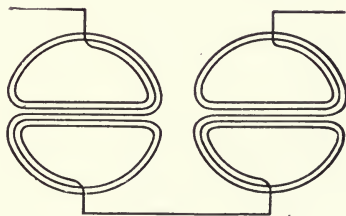

FIG. 62.

direction, and is a minimum when the coils are still parallel but carry the current in opposite directions. Another similar method is sketched in Fig. 61; the two cylinders shown are intended to be placed one inside of the other, one of them being turned on its axis. A widely used arrange-

ment is shown in Fig. 236 (TELEFUNKEN*) in which the middle one of the three flat coils (marked "28" in Fig. 236) can be swung from side to side.†

A particularly elegant construction is found in the variometer devised by R. RENDAHL,⁵³ (Telefunken). Two flat coils wound as shown in Fig. 62 are mounted face to face on a common axis (in Fig. 62 they are shown next to each other instead of face to face).

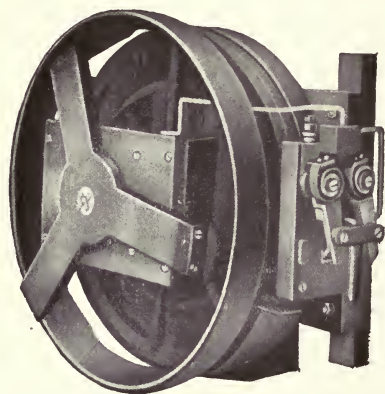

FIG. 63.

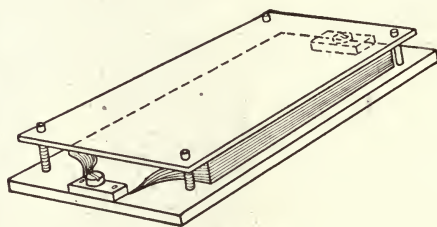

FIG. 64.

One of them turns on its axis. If it is turned so that those halves of the two coils carrying the current in the same direction are superimposed, the coefficient of self-induction will be at its maximum. If turned 180° from this position, the coefficient of self-induction becomes a minimum. The advantage of this variometer lies in its compactness (Fig. 63 shows the manufactured instrument for heavy currents and rather high potentials) and in the low stray magnetic field outside of the coils; by alternate series and parallel connection of the coils a very wide range in the self-induction can be obtained.

39. Condensers of Constant Capacity.⁵²—*a. Plate Condensers.*—Plate condensers for large capacities with *paper* as the dielectric are adaptable only for low voltages, unless a sufficient number are joined in series. Otherwise *mica* (Fig. 64) or *glass plate* condensers with coatings of tin-foil or thin sheet metal are used. Mica as the insulating mate-

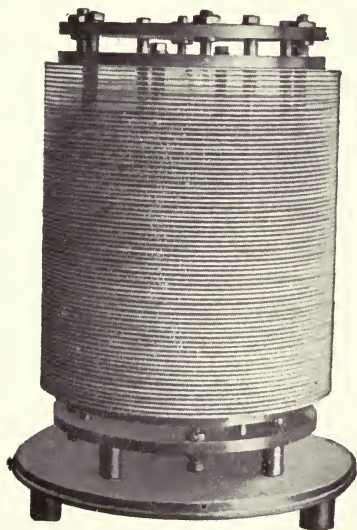

FIG. 65.

* "Telefunken" is the trade-name of the German Company of Wireless Telegraphy—"Gesellschaft fuer drahtlose Telegrafie, m.b.H.," Berlin.

† Translator's Note: This is sometimes referred to as the "butterfly" type of variometer coil.

rial, in view of its very high resistance and its comparatively high dielectric constant, permits of very small dimensions* but causes quite heavy losses through dielectric hysteresis if the load is not kept very low.

If the condenser losses are to be minimized, *air* or *oil* must be used as



FIG. 66.

the insulating material. Two constructions of air condensers are shown in Fig. 65 (GIEBE) and Fig. 66 (E. HUTH) respectively. A somewhat different arrangement is shown diagrammatically in Fig. 67 for an oil condenser as designed by J. A. FLEMING. With air condensers great care must be taken that the advantage of practically no energy dissipation is not lost by leakage discharge (of the first kind described in [Art. 14a]) or poor insulation of the non-conducting parts which serve to hold the plates in position. It is advisable to enclose these condensers in containers of glass or the like and to dry the air within thoroughly by means of metallic sodium.

An air condenser for high pressures (*compressed air condenser*) as built by the National Electric Signalling Co., at the suggestion of R. A. FESSENDEN is represented in Figs. 68 and 69. (See *b* for the advantages of compressed air.)

b. Cylindrical condensers.

The best-known form of cylindrical condenser, the *Leyden* (also the

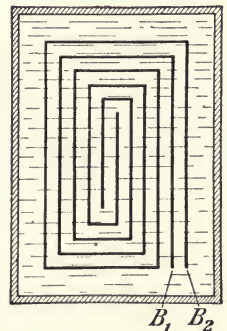

FIG. 67.

* The dimensions of a mica condenser for a breakdown potential of 1000-1500 volts for example are 26 × 54 × 8 mm. for about 0.01 MF., 26 × 54 × 14 mm. for about 0.2 MF. (C. LORENZ).

Kleit) jar, has glass for its dielectric. Glass is chosen in view of its low (dielectric) hysteresis losses and its low conductivity, while the form of the jar is chosen on account of its low leakage discharge [Art. 86]. In this connection a *long narrow form* of jar is always the most advantageous (note the battery of jars, as built by TELEFUNKEN, in Fig. 70).

The Leyden jars of J. MOSCICKI* (Fig. 71) in which the upper ends are made narrower and heavier than the main body (Fig. 72) are particularly

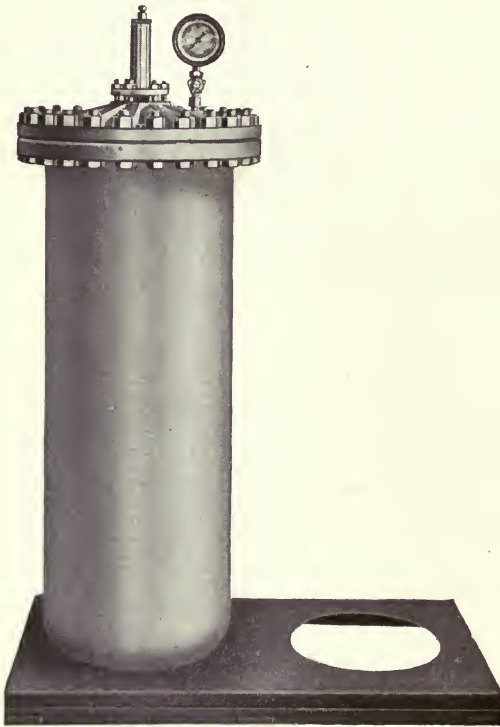

FIG. 68.

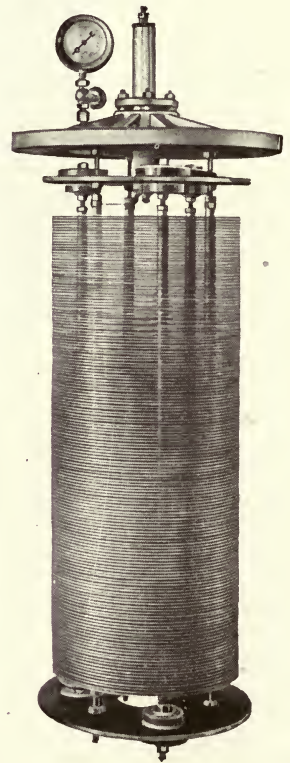

FIG. 69.

effective in minimizing the leakage discharge. The thickening of the glass at the top also increases the breakdown voltage as experience has shown that Leyden jars mostly break down at the top edge of the coatings.

The construction of these jars is evident from Fig. 72, in which P_1 and P_2 are the terminals of the two coatings, L is a metal tube, b is a rubber stopper and I is a porcelain insulator. The coating consists of a thin layer of silver chemically deposited and covered by a thicker

* Manufactured by Messrs. WOHLLEBEN & WEBER, in Saarbrücken, from whose descriptive pamphlets Figs. 71 and 72a and b are taken.⁵⁶

layer of copper. The jars are filled with a mixture of distilled water and glycerine having a low freezing point and serving to secure a good contact between the terminal P_1 and the inner coating. This also prevents a too rapid heating of the jar.

Another method for raising the breakdown voltage and minimizing

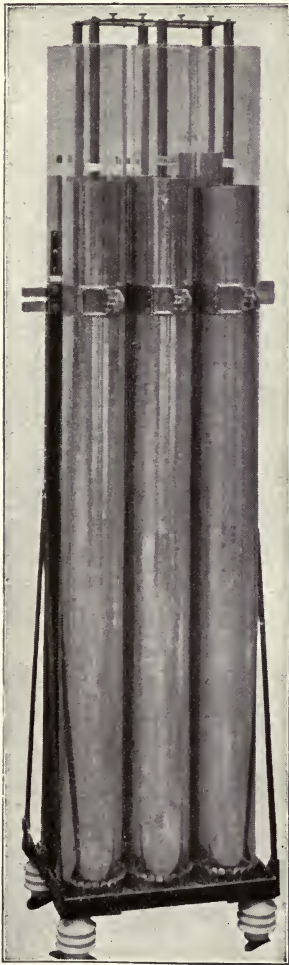

FIG. 70.

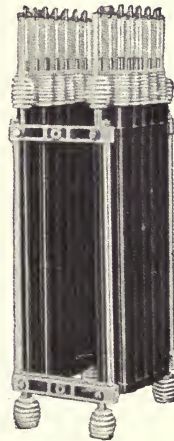

FIG. 71.

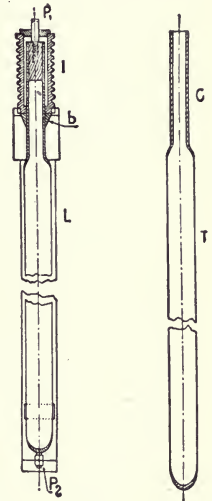

FIG. 72a. FIG. 72b.

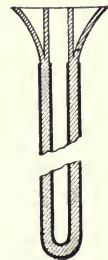
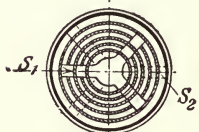
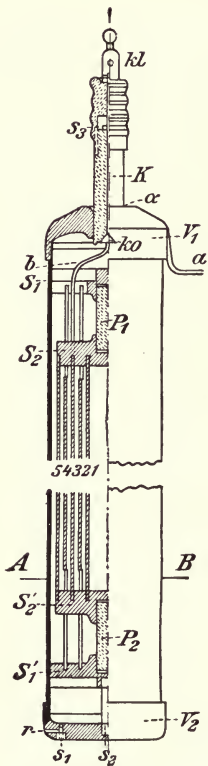

FIG. 73.

the effect of leakage discharge is shown in Fig. 73 (Allgemeine Elektrizitätsgesellschaft). The dielectric is split into two parts at the top, the outer part being bent out like an umbrella.

For purposes requiring particularly low energy loss the very handy *compressed gas condensers* as designed by M. WIEN¹⁷ are very convenient. Their design is shown in Fig. 74. The use of carbonic acid gas,



Section A-B
FIG. 74.

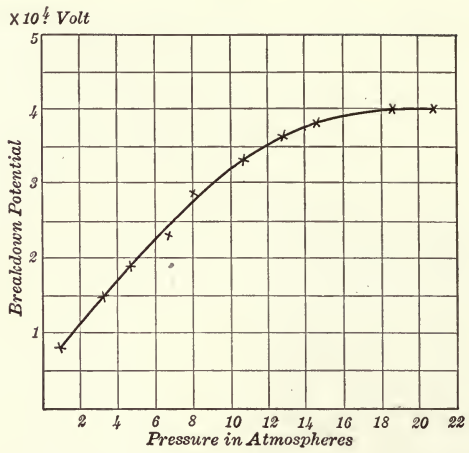

FIG. 75.

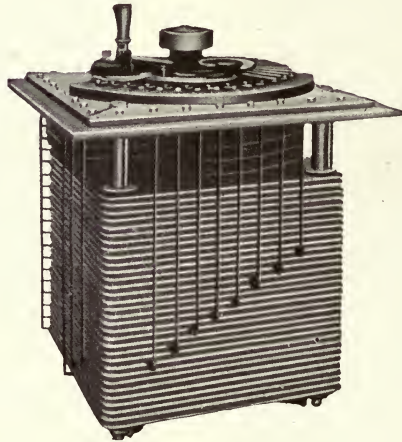

FIG. 76.

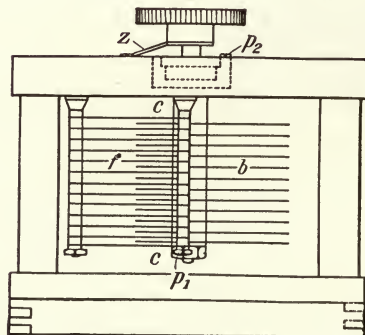

FIG. 77.

under a pressure of twenty atmospheres, greatly raises the breakdown voltage, bringing this even higher than for oil filling, so that these condensers may be used without difficulty up to about 35,000 volts, in spite of the very small space (3 mm.) between the cylinders. (See the curve in Fig. 75 for the relation of breakdown voltage to gas pressure in condensers of this type.) The high pres-



FIG. 78.

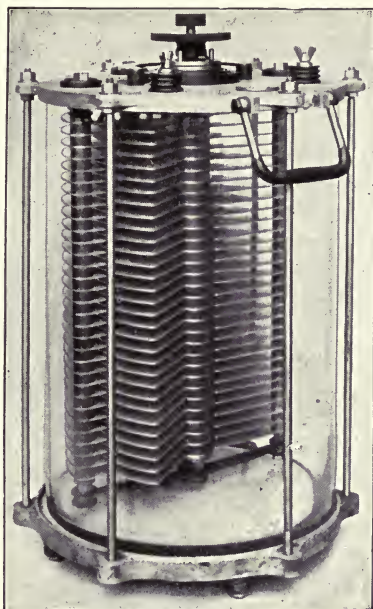

FIG. 79.

sure also reduces the leakage discharge to such an extent that it has not been possible to measure it up to potentials of about 35,000 volts.⁵⁷

40. Variable Condensers.⁵²—Condensers whose capacity is changed in steps, as that shown in Fig. 76, are seldom used. Instead of this, it is customary to use bat-

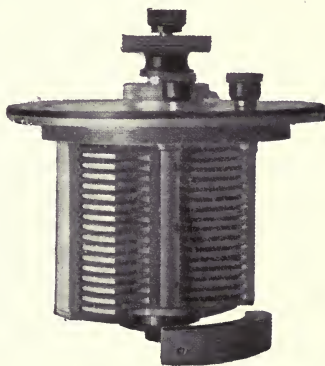

FIG. 80.

teries of Leyden jars, and vary their number according to the required capacity.

a. Continuous variation in the capacity of condensers is usually ac-

complished by varying the relative position of the two coatings or conducting plates. This form of condenser was probably first introduced into radio practice by A. KÖPSEL^{57a} in the form represented by Fig. 77.

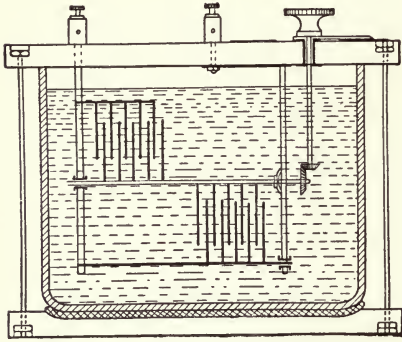

FIG. 81.

The conducting elements are made up of sets of semicircular plates or discs of which one is stationary and the other rotated into the spaces between the plates of the former. A pointer moving over a circular scale (see Fig. 77) indicates the position of the movable element. The first form of this type of condenser built by TELEFUNKEN is shown in Fig. 78. They are now made by many firms. For instance, Fig. 79 shows a construction developed by

C. LORENZ, Fig. 80 represents a precision condenser of G. SEIBT, and Figs. 81 and 82 show an arrangement with vertical plates made by C. LORENZ. The latter is said to allow of a better circulation of the

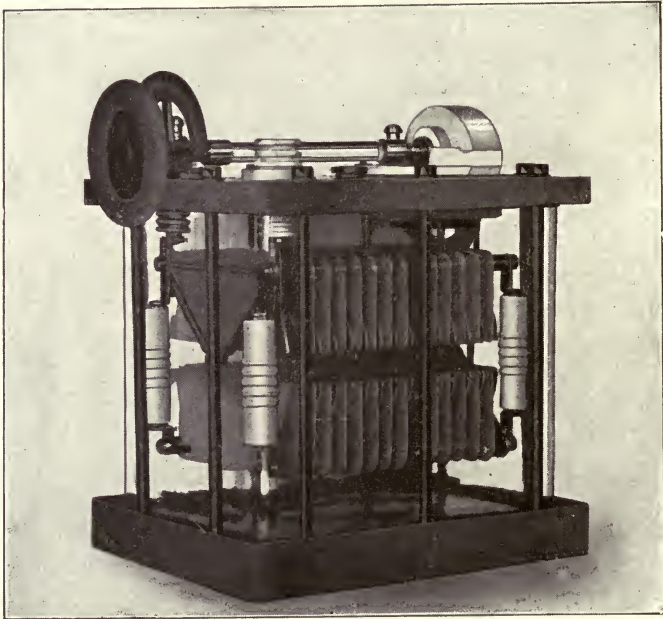

FIG. 82.

oil and to prevent air bubbles from collecting on the plates. The condenser plates as made by H. BOAS (Fig. 83) are also vertical, but cylindrical in shape.

The desire to combine maximum capacity with minimum space underlies the design of Fig. 84, C. LORENZ. It consists of a combination of two (or three) condensers of the form of Fig. 77 in such manner that the two movable sections *g* and *h* occupy a common space in one position.

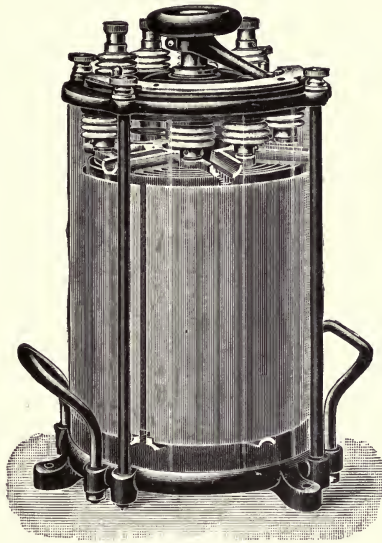

FIG. 83.

The problem of minimizing space is solved with particular nicety in the condensers of the Marconi Co. These also have the movable section made up of semicircular plates, similar to those of Fig. 77, but differ

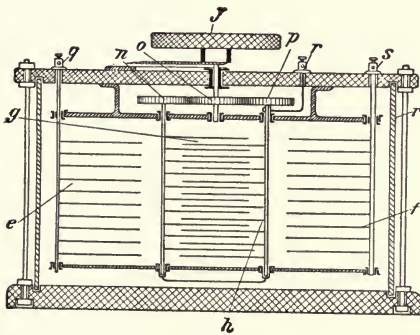

FIG. 84.

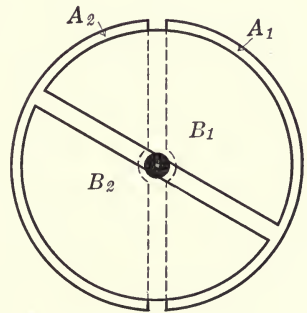

FIG. 85.

in having *two stationary* (A_1A_2 , Fig. 85) and two rotating (B_1B_2 , Fig. 85) sections arranged as shown. One stationary and one rotating set, say A_1 and B_1 , are connected to one terminal, while the others, A_2 and B_2 , are joined to the other pole. Then the capacity is greatest

when B_1 entirely covers A_2 , B_2 covering A_1 . This capacity, for the same total volume occupied and the same distance between plates, is double that of a similar condenser having only one stationary and one movable section of plates.

2. CURRENT AND VOLTAGE

41. Relation between Current and Voltage Amplitudes.—*a.* For undamped sinusoidal oscillations the relation is given by

$$I_0 = \frac{V_0}{\sqrt{R^2 + (\omega L)^2}} \tag{1}$$

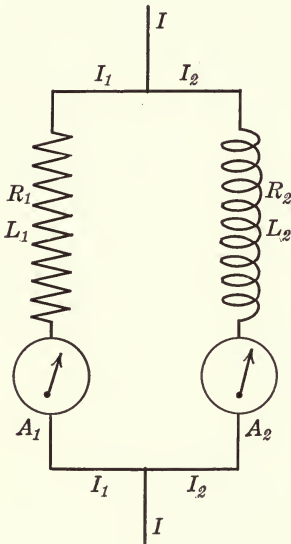

FIG. 86.

in which R and L are the resistance and coefficient of self-induction respectively of the circuit whose end-points have a difference of potential V_0 .

For damped oscillations within the limits encountered in practice,* this relation also holds approximately. It assumes an even simpler form for all wire circuits, unless these consist of particularly thin wires of low conductivity, as in these the inductance, in view of the high frequencies customary in radio practice, increases much more rapidly than the resistance. We may therefore write approximately:

$$I_0 = \frac{V_0}{\omega L} \tag{2}$$

b. If a current I (Fig. 86) divides itself into two paths one having a resistance R_1 and a coefficient of self-induction L_1 , the constants of the other being R_2 and L_2 , then we have for the ratio of the currents I_1 and I_2 in each of the parallel paths

$$\frac{I_{10}}{I_{20}} = \frac{I_{1eff}}{I_{2eff}} = \frac{\sqrt{R_2^2 + (\omega L_2)^2}}{\sqrt{R_1^2 + (\omega L_1)^2}} \tag{3}$$

If both branches are made of fairly heavy wire, then the lower the resistance is in comparison to the inductance, the more nearly accurate will be the approximate relation

$$\frac{I_{10}}{I_{20}} = \frac{I_{1eff}}{I_{2eff}} = \frac{L_2}{L_1}$$

so that the splitting of the current depends not upon the resistance but upon the coefficients of self-induction of the branches.

* *i.e.*, d is much less than 2π .

† It is assumed that the two branches do not affect each other inductively.

The two branches may be intentionally so adjusted that the resistance of one of them, say R_1 , is much greater than its self-induction while the reverse is true of the other branch. We then have:

$$\frac{I_{10}}{I_{20}} = \frac{I_{1eff}}{I_{2eff}} = \frac{wL_2}{R_1}$$

This gives a simple measure of ω and the frequency N^* from the ratio of the branch currents.

It has been frequently suggested to make use of this relation for measuring the frequency by noting the current indicated by ammeters, A_1 and A_2 , in each branch circuit. This scheme is very neatly carried out in

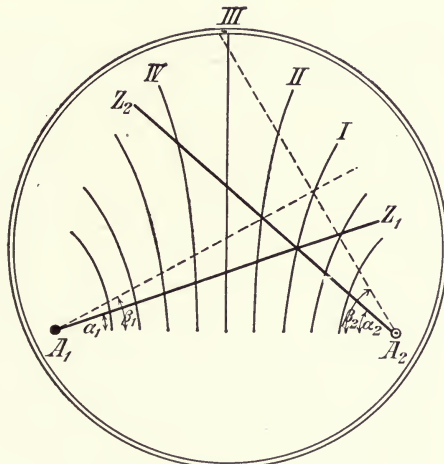

FIG. 87.

FERRIÉ'S "frequency-meter," which gives direct readings of the frequency.⁶²

The two ammeters are so arranged that their pointers A_1Z_1 and A_2Z_2 (Fig. 87) cross each other. At a given frequency, N , for any deflection, α_1 , of the pointer of A_1 only one definite deflection, α_2 , of the other instrument, A_2 , will correspond, so that the pointers will intersect at a definite point. For another current of the same frequency passing through the system, other deflections, β_1 and β_2 (dotted lines in Fig. 87), and another definite point of intersection correspond. By thus varying the current at a constant frequency, the successive points of intersection develop a curve (I in Fig. 87) which geometrically locates the frequency N on the face of the instrument. By repeating this process with other frequencies, individual curves (II , III , etc., Fig. 87) are obtained for each frequency. These curves once determined to measure an unknown

* The same in fact is true of the more general equation (3).

frequency it is only necessary to observe on which curve the instrument pointers intersect, which will indicate the desired frequency.

If one of the paths contains a *coil of very high self-induction*, while the other path contains neither high self-induction nor high resistance, then the oscillations will flow through the second path almost entirely. The first path is said to be "choked" (high frequency "choke coil").

c. In applying equation (2) to an entire condenser circuit (*AFB*, Fig. 1) the difference of potential between the condenser coatings* must be taken for V and the coefficient of self-induction of the entire circuit substituted for L .

If capacity is introduced in place of self-inductance, we have:

$$I_0 = \omega C.V_0^{63} \quad (4)$$

To illustrate the application of this formula, consider the condenser circuit formerly installed at the German station in Nauen (TELEFUNKEN). Its effective capacity was 0.44 *MF.*, the frequency about 1.5×10^5 /sec. With 60,000 terminal volts, we have

$$\begin{aligned} I_0 &= 2\pi \times 1.5 \times 10^5 \times 0.44 \times 10^{-15} \times 60,000 \text{ C.G.S. units} \\ &= \text{approx. } 2500 \text{ C.G.S. units} = 25,000 \text{ amp.} \end{aligned}$$

It should be noted that the current amplitude is very great, even from the standpoint of commercial light and power circuits.

d. Equation (4) holds in general for any condenser in the circuit, if C is its capacity, V the potential difference of its coatings and I is the current in the circuit. If the capacity C is very great, V_0 becomes very small; in this case the condenser acts as a *short circuit* for the oscillations, while it would offer an infinitely great resistance to a direct current. It may therefore be used to "block" or protect the circuit against a direct current without appreciably affecting the oscillations.

42. The Breakdown Voltage and Gap Length.⁶⁴—A given voltage, V , say that existing across the plates of a condenser, may be measured by its "*breakdown gap*," *i.e.*, the length of a gap in air or gas over which the voltage V would just discharge itself.† The relation between the length of the gap and the breakdown potential depends on the form of the electrodes (on their radius in case of spheres), on the particular kind of gas in the gap as well as its condition, and the method of charging the electrodes, *i.e.*, whether a static charge has been supplied by a friction or influence machine, or whether the charge is produced by oscillations or by an induction coil.

* For several condensers in series this would be the sum of their potential differences.

† This is also known under various other names such as "*discharge voltage*," "*rupture voltage*," and is also identical with the "*ignition voltage*," V_z , mentioned in Art. 129.

a. The relation of gap length and breakdown voltage for air and static charges is given in Table IX.

From these curves it will be noted that for short gaps the size of the electrode (radius of the sphere) has but little effect. Its importance increases, however, with each increase in gap length, so that with very small spheres the breakdown voltage increases only very slowly for increasing gap length, while with large spheres it remains in approximate proportion to the gap length up to much greater distances. With plate or disc electrodes (Fig. 88) the relations are similar to those for spheres of very large diameter.

b. If the charge on the electrodes is produced by *oscillations*, the relation between breakdown potential and gap length is also affected by the frequency. The higher the frequency, the higher is the voltage necessary to jump a gap of given length.⁶⁵



FIG. 88.

This is due to the fact that when the voltage is reached at which a discharge would finally occur if this voltage were maintained, *i.e.*, the *normal breakdown voltage* (Table IX), the discharge does not take place immediately and the voltage will have risen above the normal discharge value at the instant at which the discharge actually takes place.* This phenomenon is called "**retardation**" or "**lag of the discharge**" (E. WARBURG).⁶⁶ It plays an important part in wireless telegraphy, as in radio practice the high potential usually exists only for very brief periods (*e.g.*, in induction coil interrupters, alternating-current transformers and even more so with high frequency oscillations). The cause of this phenomenon lies in the low number of ions contained by the gas in the gap. Its occurrence can be prevented by providing a sufficient quantity of ions in the gas. This is most easily attained by subjecting the negative electrode (both electrodes in the case of alternating-current operation) to ultraviolet light, thereby inducing the emission of negative electrons. This method is advisable wherever it is important that the spark discharge occur always at the same potential. In fact, if properly applied even for radio frequencies the breakdown voltages and gaps will be practically the same as for static charging, and the values of Table IX may be applied without appreciable error.⁶⁵

c. The discharge voltage is *reduced* under the conditions encountered in radio practice by heating the electrodes, in fact by any strong ionization of the gas. In practice ionization is usually produced by immediately preceding discharges. If a number of spark discharges are passed over a gap in rapid succession, the voltage may be reduced very considerably from that required for the initial discharge.

The breakdown potential may be *increased* by raising the pressure

* Apparently the phenomenon described in *c* is also due to this condition.

above atmospheric. Up to about 10 atmospheres the discharge voltage is approximately proportional to the pressure [see Art. 39b].

The breakdown potential is not much different for *various gases* such as air, nitrogen, oxygen, carbon dioxide, etc. However, it is only about one-half as great for *hydrogen* as for those mentioned, and much lower still for helium and argon.

d. So-called "**micrometer gaps**" as illustrated in Fig. 89 serve for *measuring the breakdown gap*. K_1K_2 are the spherical electrodes, G_1G_2 good insulators of glass or, better yet, porcelain, S_1 a micrometer screw, S_2 the lever head of a set screw, not otherwise visible in the illustration. If S_2 is loosened the electrode on the left can be moved away from or nearer to the other electrode, while the micrometer screw, S_1 , serves for the fine adjustments.

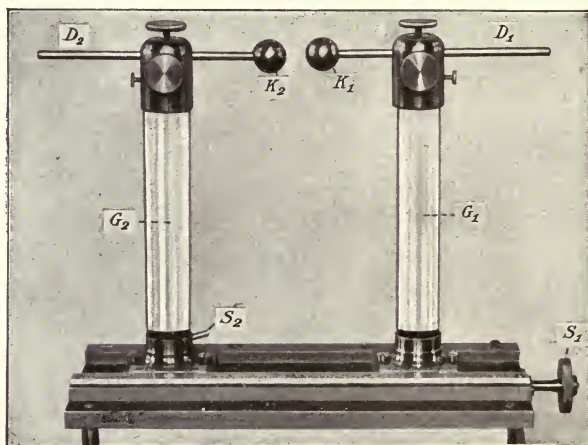

FIG. 89.

The radius of the spheres K_1 and K_2 should be chosen at least as great as the gap length being measured. Moreover, the field between the electrodes must not be disturbed by any conductors in its vicinity if results for general comparison are desired and the values of Table IX are to be used.

43. Insulation of Conductors.—*a.* In view of the high voltages which occur when working with damped oscillations, there is often great danger of a spark discharge between two points of the circuit. Hence *the conducting circuit must be carefully insulated against spark discharges*. For example, if a spark jumps across from A to B in the condenser circuit shown in Fig. 90, practically the entire current will flow via AF_1B , as this path offers a much lower impedance than the path ADB , and thus the entire oscillation will be changed.

b. On the other hand, *insulation against current losses* in circuits

charged by *damped oscillations* is not so essential⁶⁷ as it is for high tension direct current or commercial alternating current or even for *undamped* high frequency current.

For instance, if *A* and *B* in Fig. 90 were joined by a poor insulator, say a wooden strip, this would not perceptibly impair the oscillations, in spite of the high voltage developed between *A* and *B*, for the length of time during which the potential between *A* and *B* is at all high is so short for damped oscillations of such decrements as come into question in practice that the loss across the strip of wood becomes very small—unless the number of discharges per second is extremely great.

Nevertheless, to insure against unnecessary energy losses the best insulating materials (porcelain and, second in rank, oil and hard rubber) should always be used.

c. All parts subjected to high voltages from the induction coil or transformer must be insulated with the greatest care, otherwise very heavy losses may result.⁶⁷ In circuits having several condensers in series, only the portions *FC*₁ and *FC*₂ (Fig. 11) require heavy insulation; but if there is only one condenser or there are several in parallel in the circuit, then the entire circuit requires careful insulation. In this respect the connection of condensers in series may at times offer a considerable advantage.

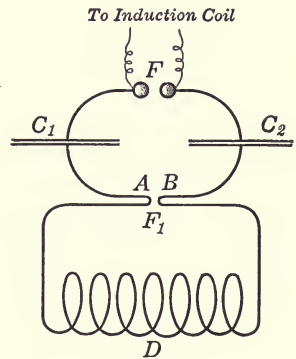

FIG. 90.

3. MEASUREMENT OF CURRENT

44. The Indications of Hot-wire Instruments.—*a.* Under hot-wire instruments, in the broadest sense, should be understood those instruments whose deflection is caused by the development of heat due to the current passing through a wire.

The deflection of such an instrument is a measure of the average quantity of heat, *Q*,* developed per second. In general, the heat developed per second in a wire of effective resistance *R* is

$$Q = RI_{eff}^2 \tag{1}$$

in which *I*_{eff}² is the mean value of *I*², the **current effect**.⁶⁸

For *undamped* sinusoidal oscillations

$$I_{eff}^2 = \frac{1}{2} I_0^2 \tag{2}$$

so that

$$Q = \frac{1}{2} RI_0^2.$$

* The deflection need not be *proportional* to *Q*, but is approximately so in most instruments.

For *damped* oscillations whose amplitude curve is of the *exponential form*, the heat developed during one discharge

$$= R \frac{I_0^2}{4Nd}$$

If then there are ζ discharges per second, the total quantity of heat developed in 1 *second*

$$Q = R \frac{\zeta}{4Nd} I_0^2 \quad (3)$$

Comparing this with equation (1) we obtain

$$I_{eff}^2 = \frac{\zeta}{4Nd} I_0^2 \quad (4)$$

For *damped oscillations* whose amplitude curve is a *straight line*⁷⁰

$$I_{eff}^2 = \frac{\zeta}{6Na} I_0^2 \quad (5)$$

in which a is the lineal decrement [Art. 9a].

b. As the effective resistance, R , of a wire depends on the frequency, the same is true of the indications of hot-wire instruments. These, however, can be made *independent of the frequency* (also usually making calibration with direct current possible at the same time) by the use of very thin wires [Art. 36*b*] whose diameter is less than that given in Table VIII.*

c. A hot-wire instrument calibrated with direct current gives direct readings for the *current amplitudes* of *undamped* oscillations, if the latter are approximately sinusoidal [equation (2)].

This is not the case with *damped* oscillations, as here not only the current amplitude but also the decrement, d , the frequency, N , and the number of discharges per second, ζ , enter as factors [equation (3)]. Only when these are known is it possible to calculate the current amplitude from the indication of a hot-wire instrument.

d. A method for determining the frequency and the decrement for the case of exponential decrease of the amplitude will be given later [Art. 74, *et seq.*]. The number of discharges per second, when using induction coils or some form of motor-driven interrupter, is easily determined from the speed, on condition that each interruption corresponds to only *one* discharge, so that the number of interruptions and the number of discharges are identical. The same relation holds between the number of alternations and the number of discharges when operating with alternating current. In general, the number of discharges and the number of interruptions (or of alternations) are not identical. If the

* The instrument's independence of the frequency is again destroyed as soon as a shunt is connected to the instrument for adjusting its sensibility.

primary current is sufficiently strong, each interruption (or each half period of alternating current) will be accompanied by several "partial discharges" or "partial sparks." Whether or not this is occurring is easily determined by observing the spark image in a rotating mirror. If this appears as shown in the photograph reproduced in Fig. 91, there



FIG. 91.

are no partial discharges, while an image as shown in Fig. 92 indicates the presence of partial discharges.*

If the image of the spark gap in a rotating mirror is photographed,



FIG. 92.

then the number of discharges per second can be calculated from the distance between the successive images on the photograph, the speed of the mirror and the dimensions of the outfit. If the spark itself is invisible, an oscillograph (with incandescent lamp) or a Braun tube can be used in conjunction with a rotating mirror to count the discharge frequency. A more convenient indicator for this purpose is the *discharge analyzer*† of J. A. FLEMING, which consists of a GEISSLER (helium or neon) tube attached to the armature of a small motor.

Fig. 93 shows the construction, Fig. 94 a finished instrument, as made by C. LORENZ. If the two terminals P_1 and P_2 are respectively connected to two points of a condenser circuit or other oscillator, a high frequency current will pass through the helium tube (d , Fig. 93‡) which lights at each discharge. The speed of the motor is regulated to a point at which the image of the tube appears stationary to the eye. If it appears as shown in Fig. 95, it follows that there are four discharges during every complete revo-

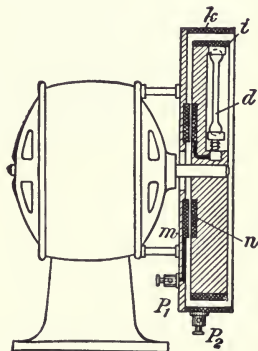

FIG. 93.

* With a little practice this can also be determined from the *sound* of the spark, which for partial discharges tends to become hissing rather than crackling.

† Also frequently called "oscillation analyzer."

‡ The metal rings m and n form the electrodes of a condenser, the rings k and i forming another. The tube is connected between these two.

lution of the motor,^{51a} while if it has the appearance of Fig. 96, there are four groups of three partial discharges each per revolution.



FIG. 94.



FIG. 95.



FIG. 96.

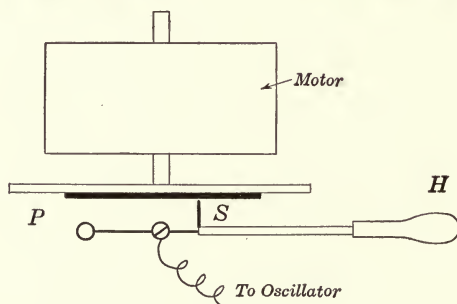

FIG. 97.

Another simple and convenient method is that sketched in Fig. 97.⁷¹ On the shaft of a small motor a photographic plate or film, *P*, is attached. Very near to this is a metallic point, *S*, which is conductively

connected to a point of the oscillator and is quickly moved across the plate by means of the handle *H*. Each oscillation is accompanied by a discharge between the point *S* and the plate, which, when developed, shows a series of dark points arranged on a spiral, each point representing a discharge. From these points, knowing the speed of the motor, the number of discharges per second is easily obtained, independently of the velocity at which *S* is moved over *P*.

45. Commercial Hot-wire Instruments.—Some hot-wire ammeters may be used for high frequency oscillations, **without any shunt**. It is preferable, however, to use instruments especially made for high frequency currents, as those, for instance, of HARTMANN AND BRAUN⁷² (FRANKFORT A. M., Bockenheim, Germany).

The type shown in Fig. 98 is intended for heavy currents, that

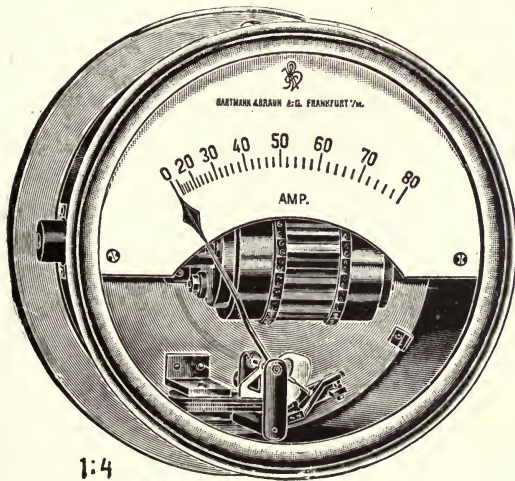

FIG. 98.

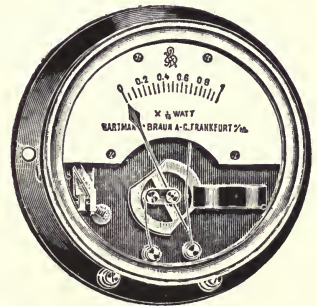

FIG. 99.

shown in Fig. 99 being designed for a minimum energy consumption. The scale of the former gives the value of I_{eff} in amperes, while the latter indicates the energy used in the instrument in watts,* which is proportional to I_{eff}^2 . In the latest and most sensitive instruments of this type, the energy consumed amounts to only about 0.015 watt.

46. The Hot-wire Air Thermometer.—The *air thermometer* or *hot-wire air thermometer* devised by RIESS (Figs. 100 and 101) and brought into radio practice by F. BRAUN is a particularly simple laboratory instrument. It consists of a glass cylinder provided with an alcohol manometer and a glass stopcock, by means of which the difference between the pressure within and the outside atmospheric pressure can be

* This is not a sufficient excuse for the common misnomer of "hot-wire wattmeter" so frequently applied to this instrument.

equalized. The hot wire, H , is at the bottom of the glass cylinder,⁷³ between two heavy entrance wires which are led in through a stopper, the glass cylinder usually being surrounded by a vacuum chamber and sometimes in addition by a silver coating. Current passing through H heats this and also the air in the glass cylinder, causing an increase in the pressure, which is indicated by the manometer. These instruments are best calibrated with direct current.

47. Bolometer, Barretter.⁷⁴—The hot wire, w , in Fig. 102 is connected as one arm of a *Wheatstone Bridge*, which is adjusted until no current flows through the galvanometer, g . If now we send an alternating current, i , through w (AB), this wire becomes hot and its resistance increases, and the galvanometer deflection caused thereby is pretty nearly in exact proportion to the current effect of i .

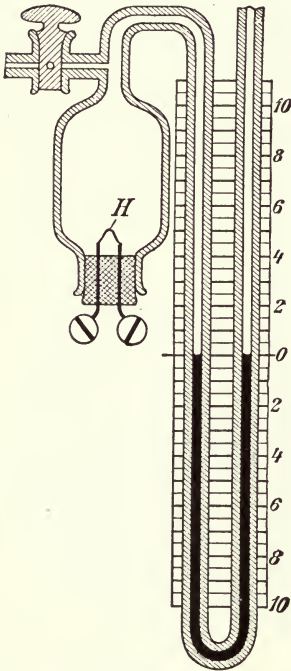

FIG. 100.

A somewhat different arrangement of this device, which is called a bolometer, is shown in Fig. 103. The branches pqr s and $p_1q_1r_1s_1$ which replace w and c in Fig. 102, respectively, are made of thin iron or platinum wire and as nearly alike as possible, and the arms pqr and s are so equalized that if direct current is applied at E and F , the galvanometer g shows no deflection, so that the points C and D have the same potential with direct current.

This arrangement has the following advantages: (1) The bolometer is less affected by variations in the room temperature, as pqr s and $p_1q_1r_1s_1$ are subjected to the same influence; (2) at most, only a very small portion of the alternating current led in through A and

B flows into the other circuits of the bridge or into the galvanometer,* as the points C and D remain at practically equal potential even with a variable current.

On the other hand, the simpler arrangement shown in Fig. 102 has the advantage that the hot wire can easily be put into a vacuum in a glass tube. This greatly reduces the heat lost by convection, considerably increasing the sensitiveness (FESSENDEN, TISSOT). Similarly, the use of extremely thin wires in this arrangement is advantageous as compared to the method of Fig. 103. This also tends toward high sensitiveness. The calibration curve shown in Fig. 104 is that of a bolometer

* Choke coils must be connected at each end of the hot wire for this purpose in the arrangement of Fig. 102.

of BÉLA GÁTI,⁷⁴ having a gold wire* of 0.002 to 0.003 mm. diam., while a bolometer with a 0.0005 platinum wire gave a deflection of ten scale divisions for 0.034 milliampere, with the same galvanometer. B. S.

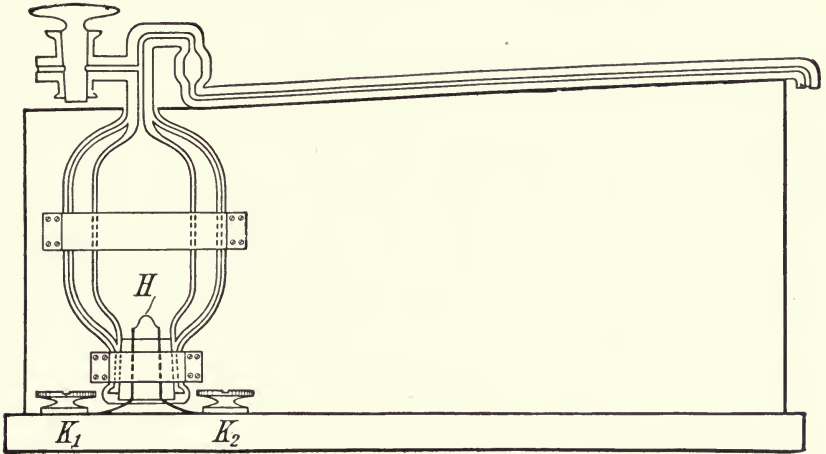

FIG. 101.

COHEN⁷⁴ was able to measure currents as low as 5×10^{-3} milliamperes by means of a carbon filament in a vacuum.

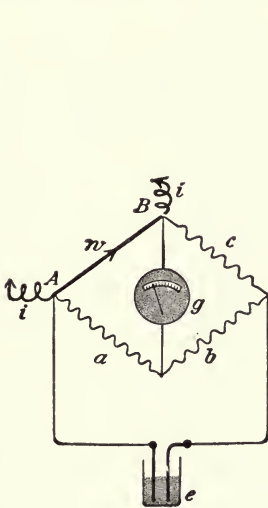

FIG. 102.

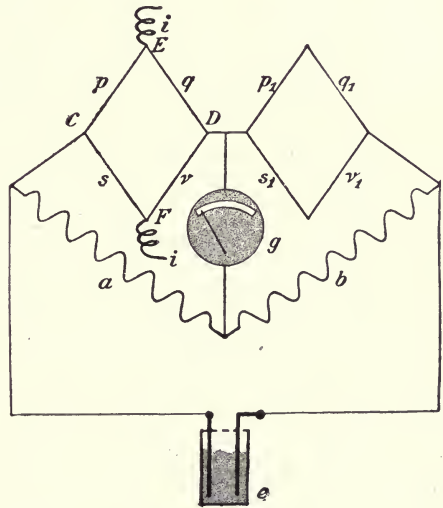

FIG. 103.

* Galvanometer = movable coil galvanometer, direct reading; one scale division = 1×10^{-6} amp. BÉLA GÁTI makes use of a special compensation method of connection instead of the complete bridge arrangement. Using a single pivot galvanometer made by PAUL (London) ($1^\circ = 1 \times 10^{-7}$ amp.) he obtained a deflection of 5° at 0.001 milliampere with the 0.0005 mm. platinum bolometer.

48. **Thermoelement⁷⁵ or Thermocouple.**—*a.* KLEMENČIČ adopted the form illustrated in Fig. 105* for the thermoelements used in the measurement of electric oscillations. *A* and *B* are thick wires through which the oscillations are led in, while the wires *c* and *d* connect to a galvanometer. *a*₁*a*₂ and *b*₁*b*₂ are very thin wires of different material (e.g., constantan and iron or

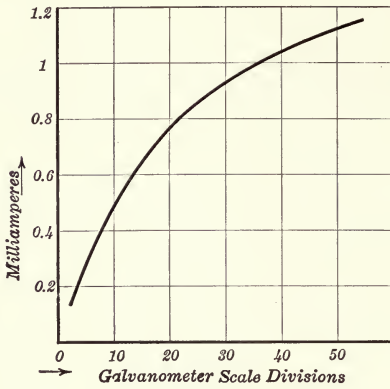

FIG. 104.

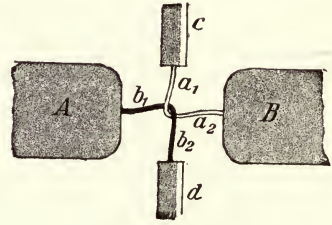

FIG. 105.

constantan and platinum). If oscillations pass through the wires *AB*, the wires *b*₁*a*₂ become heated as do also the points of contact of the wires *a*₁*a*₂ and *b*₁*b*₂, the heat developed at these points of contact being

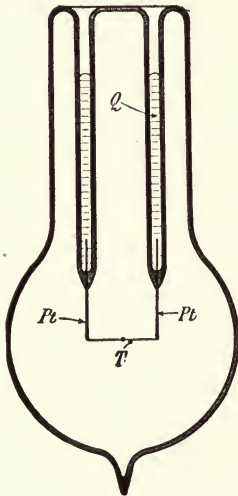

FIG. 106.



FIG. 107.

greater than at the soldered points *a*₁*c* and *b*₂*d*. This uneven heating produces a thermoelectric EMF and a deflection of the galvanometer.

* Greatly enlarged.

b. The sensitiveness of these thermoelements is greatly increased by enclosing them in a *high vacuum*, as shown by P. LEBEDEV. H. BRANDES⁷⁵ has designed a very simple construction for this, shown in Fig. 107, while Fig. 106 shows a diagrammatic cross-section through two of the four wires.*

A particularly good thermoelement is obtained by the combination of tellurium with constantan or tellurium with platinum (say a thin platinum wire sweated on to a small ball of tellurium) (L. W. AUSTIN).⁷⁵

c. An advantage of the thermoelement as compared to the bolometer is that no auxiliary cell (*e*, Fig. 103) and no equalizing of the bridge are necessary.

Both bolometer and thermoelement require only a very small amount of heat and hence only a very small amount of energy to produce a considerable deflection, particularly if a highly sensitive galvanometer is used, wherein lies their great advantage over hot-wire air thermometers or the commercial hot-wire instruments. For many purposes the very convenient direct-reading movable coil galvanometers are sufficient; however, if measurements necessitating the lowest possible energy consumption are to be made, a good mirror galvanometer, not too extremely damped, is more suitable.

Calibration of these is best obtained with alternating current and an electrodynamic precision voltmeter without a multiplier.

49. The Thermogalvanometer.—There is one instrument even more sensitive than either the thermoelement or the bolometer of usual design, viz., the *thermogalvanometer*, constructed by H. DUBDELL⁷⁶ following an arrangement of C. V. BOYS for measurements with high frequency oscillations.

The principle is as follows: Between the poles *N* and *S* (Fig. 108) of a horseshoe magnet a movable wire frame *L* is suspended similarly to a movable coil galvanometer. A thermocouple (antimony-bismuth) is attached at the lower end of the suspended frame, giving a very high EMF. At one junction point a hot wire or thin strip of gold-leaf or strip of a platinum mirror on glass is attached, through which the oscillations are passed. This heats the strip and thereby also the junction point, producing an EMF and a current in the frame. The latter is thereby

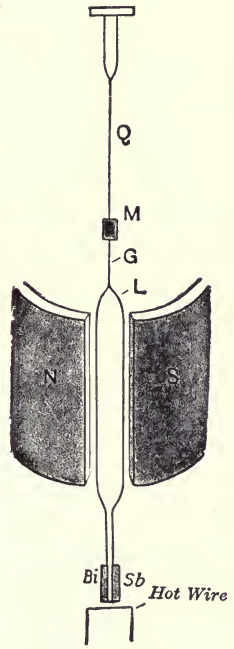

FIG. 108.

* Thermoelements and bolometers are disadvantageous when a vacuum is used, in that they cannot be repaired when they burn out, which occurs frequently as it is difficult to provide reliable fuses. When no vacuum is used, it is a simple matter to replace the burned wire.

deflected just as in a movable coil galvanometer, a mirror and scale serving to measure the deflection.

Fig. 109 illustrates a construction of such an instrument* said to be characterized not only by its sensitiveness, but also by its convenience.

W. GERLACH⁷⁷ has devised an arrangement similar to the thermogalvanometer, having the highly sensitive thermocouple, which is acted upon by the hot-wire strip, connected to a separate sensitive galvanometer.

50. Comparison of the Sensitiveness of Various Measuring Instruments.⁷⁸—The following table gives the energy consumption at a deflec-

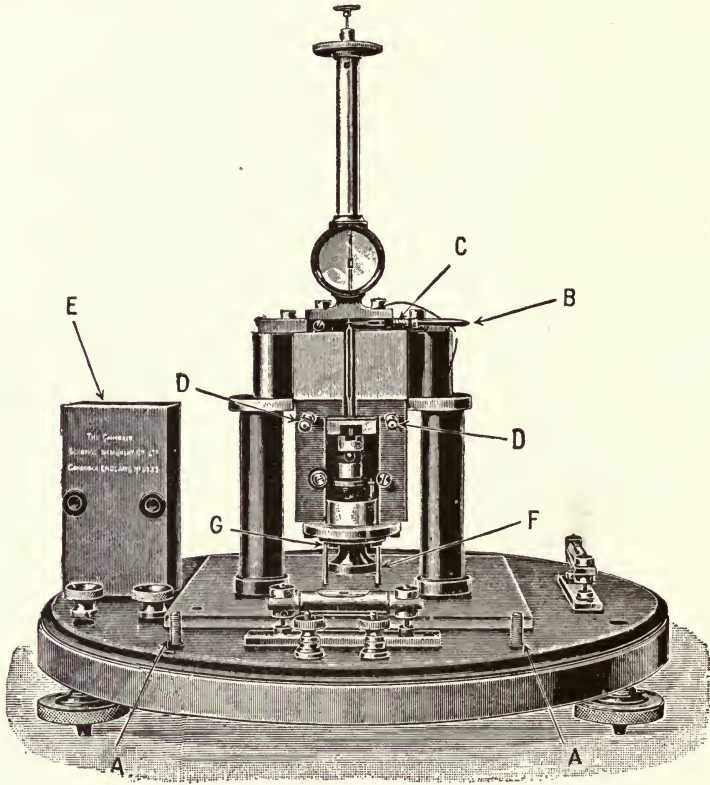

FIG. 109.

tion of 100 mm. or 100 scale divisions for various instruments, this serving as a measure of their sensitiveness. This, however, is not by any means a measure of their practical usefulness, which depends on quite other properties.

51. Measurement of Very Small Currents.⁷⁹—For the measurement of *very* small currents the various detectors discussed later (*e.g.*, galena-

* As made by the Cambridge Scientific Instrument Co. Figs. 108 and 109 are taken from a pamphlet issued by this company.

Kind of instrument	Constants of galvanometer used	Method of reading	Resistance in ohms	Corresponding values of current and deflection	Watts consumed for deflection of 100 mm. or 100 scale divs.
Hot-wire air thermometer. Copper wire of 0.02 mm. diam., 1 cm. long. ¹	Direct reading	0.78	100 mm. deflection 0.178 amp.	247×10^{-4}
Hot-wire air thermometer. Manganin wire of 0.02 mm. diam., 3.6 cm. long. ¹	Direct reading	34.0	100 mm. deflection 0.024 amp.	200×10^{-4}
Hot-wire instrument of Hartmann and Braun (most sensitive type). ²	Direct reading	9.37	Entire scale = approx. 45 cm. 0.04 amp.	333×10^{-4}
Bolometer of Béla Gáti. Platinum wire of 0.0025 mm. diam. ³	Resistance = 60 ohms Sensitivity: 1° = 10^{-6} amp.	Direct reading	44.0	10° deflection 0.001 amp.	4.4×10^{-4}
Bolometer without vacuum. Iron wire of 0.02 mm. diam. ⁴	Resistance = 225 ohms Sensitivity: 1 mm. = 8.55×10^{-9} amp.	Mirror ⁵ reading	1.8	100 mm. deflection 0.0117 amp.	2.46×10^{-4}
The same with vacuum ⁴	Resistance = 225 ohms Sensitivity: 1 mm. = 8.55×10^{-9} amp.	Mirror ⁵ reading	2.2	100 mm. deflection 0.002 amp.	0.088×10^{-4}
Thermoelement of Voege. Iron and constantan 0.02 mm. diam., vacuum. ⁶	Resistance = 30 ohms Sensitivity: 1 sc. div. = 2.5×10^{-8} amp.	Mirror ⁵ reading	3.6	100 mm. deflection 0.0126 amp.	5.68×10^{-4}
Brandes thermoelement. Iron and constantan 0.025 mm. diam., no vacuum. ⁷	Resistance = 60 ohms Sensitivity: 1 mm. = 8.55×10^{-9} amp.	Mirror ⁵ reading	5.1	100 mm. deflection 0.036 amp.	66.1×10^{-4}
The same with vacuum ⁷	Resistance = 60 ohms Sensitivity: 1 mm. = 8.55×10^{-9} amp.	Mirror ⁵ reading	5.1	100 mm. deflection 0.006 amp.	2×10^{-4}
Duddell-thermogalvanometer. Gold heater ⁸	Mirror ⁵ reading	18.0	100 mm. deflection 320×10^{-6} amp.	0.046×10^{-4}
Duddell-thermogalv. Platinum on glass ⁸	Mirror ⁵ reading	103.0	100 mm. deflection 138.4×10^{-6} amp.	0.049×10^{-4}
Duddell-thermogalv. Platinum on glass ⁸	Mirror ⁵ reading	202.5	100 mm. deflection 110×10^{-6} amp.	0.061×10^{-4}
Duddell-thermogalv. Platinum on glass ⁸	Mirror ⁵ reading	363.0	100 mm. deflection 92.4×10^{-6} amp.	0.077×10^{-4}
Duddell-thermogalv. Platinum on glass ⁸	Mirror ⁵ reading	1,071.0	100 mm. deflection 48.4×10^{-6} amp.	0.063×10^{-4}
Duddell-thermogalv. Platinum on glass ⁸	Mirror ⁵ reading	3,367.0	100 mm. deflection 33.2×10^{-6} amp.	0.104×10^{-4}
Duddell-thermogalv. Platinum on glass ⁸	Mirror ⁵ reading	13,910.0	100 mm. deflection 12.4×10^{-6} amp.	0.055×10^{-4}

¹ Tests in the Physik. Institut Braunschweig (for form of the instrument see Fig. 88). ² According to Messrs. Hartman and Braun. ³ According to Mr. Béla Gáti; Bridge current 0.02 amp. (see Art. 47). ⁴ Tests in the Physik. Institut Braunschweig; Bridge current 0.09 amp., current in bolometer wire 0.04 amp. ⁵ With mirror readings a distance of 1 m. from the scale is assumed throughout. ⁶ E.T.Z., 1906, p. 467. ⁷ Tests in the Physik. Institut Braunschweig. ⁸ As constructed by the Cambridge Scientific Instrument Co., according to their pamphlet.

graphite [Art. 150], or red zinc oxide-copper pyrites [Art. 160], or the audion detector [Art. 161c]) can be used to advantage.

They are used in connection with a galvanometer (arranged for instance as shown in Fig. 375 in the circuit S_2C' , by substituting the galvanometer for the telephone) or with a telephone (as in Fig. 375). In the first case the galvanometer deflection gives a direct measure of the alternating current* passed through the circuit, while in the second case there are two methods for arriving at the current value.*

Either an adjustable resistance is connected in parallel to the telephone and varied until the sound heard in the telephone becomes just audible—the smaller the resistance necessary, the greater is the alternating current measured—(the so-called “*parallel-resistance*” method), or the unknown alternating current is caused to induce current through an adjustable coupling [Art. 54] in a circuit containing the detector and telephone—the looser the coupling for a just disappearing sound, the greater is the measured current.

Such devices must always be calibrated before being used, and even then are adapted for accurate measurements only if the detector can be relied upon for entirely constant action. Their great advantage, however, lies in that their sensitiveness is of quite another order⁷⁹ than that of the apparatus described in Arts. 47–49.

* That is, the effective current value, when thermodetectors are used.

CHAPTER IV

COUPLED CIRCUITS

1. COUPLING IN GENERAL

52. Magnetic, Galvanic, Electric Coupling.—Two electromagnetic systems (oscillators or closed current circuits) are said to be “coupled” if they are so arranged that oscillations in one of the systems always cause oscillations in the other. That system or circuit in which the energy is first supplied, say from an induction coil or similar source, is called the “primary circuit,” the other being called the “secondary circuit.”

a. Magnetic or Inductive Coupling.—In this case the mutual action of the two systems is procured only through their magnetic field: mutual induction* of the two circuits. Fig. 110 illustrates a case of this kind

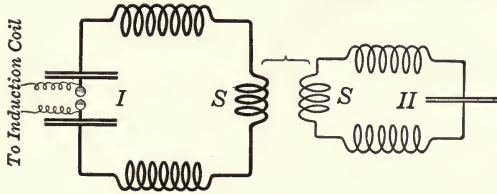

FIG. 110.

for two condenser circuits; the bracket between the two coils *SS* is intended to indicate, here and in following diagrams, that the coils are mutually inductive.

b. Galvanic or Conductive Coupling.—In Fig. 111, which shows a case of this kind, the parts drawn in heavy lines may be considered as constituting the primary circuit, while the fainter lines together with the coil *S* form the secondary system; the coil *S* is therefore common to both circuits. The arrangement of Fig. 111 may be conceived as having been developed from that of Fig. 110 by first winding the two coils *S* of Fig. 110 next to each other on a common core, as illustrated by the coils *S*₁ and *S*₂ of Fig. 112, and finally superimposing them until they become a single winding. It is evident that in this case there is a magnetic coupling of the two circuits just as there is in Fig. 110—the

* For the electromotive forces E_{i1} and E_{i2} induced in *I* by the secondary circuit and in *II* by the primary circuit, we have, as is well-known:

$$E_{i1_0} = \omega L_{1_0} \times I_{2_0}; \quad E_{i2_0} = \omega L_{2_1} \times I_{1_0} \text{ } ^{80}$$

current I_1 in the primary circuit produces a magnetic flux in the coil S , which flux in turn induces an EMF in the secondary circuit which also contains S .

However to the magnetic coupling there is here added another kind of coupling. Even if S in Fig. 111 were a non-inductive (*e.g.*, electrolytic) resistance and both circuits were so arranged that absolutely none of the magnetic lines of force of one could pass through the other (that is their mutual inductance were zero), there would nevertheless exist a coupling of the two circuits. The current in the primary circuit would cause a difference of potential between the ends of S which would in turn cause a current to flow in the secondary circuit. This kind of coupling is called "galvanic" or "conductive."

Fig. 111 therefore illustrates a *combination of magnetic and galvanic coupling*, which is frequently referred to as "direct coupling."⁸¹

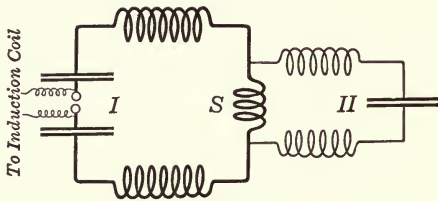

FIG. 111.

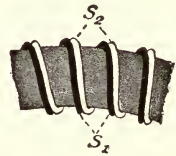

FIG. 112.

In this case to the electromotive forces E_{i1} and E_{i2} produced in the primary and secondary circuits by their magnetic coupling there are added the electromotive forces E_{g1} and E_{g2} caused by their galvanic coupling, the various values being:⁸¹

$$\begin{aligned} E_{g1_0} &= RI_{2_0}; & E_{i1_0} &= \omega L \times I_{2_0} \\ E_{g2_0} &= RI_{1_0}; & E_{i2_0} &= \omega L \times I_{1_0} \end{aligned}$$

(R and L are the effective resistance and coefficient of self-induction of the coil S in Fig. 111). It follows that

$$\frac{E_{i1_0}}{E_{g1_0}} = \frac{E_{i2_0}}{E_{g2_0}} = \frac{\omega L}{R}$$

i.e., the ratio of the amplitudes of the electromotive forces due to magnetic coupling to those due to galvanic coupling is equal to the ratio of the inductance of the coil S to its resistance. However, according to Art. 41a, the inductance of wire circuits (such as are generally used in radio-telegraphy), if not made of extremely thin or very poorly conducting wires, is usually much greater than the resistance.

Hence in all practical cases of importance involving a combined magnetic and galvanic (direct) coupling, *the effect of the magnetic coupling only* need be considered. The connections shown in Fig. 111 may therefore be considered as practically identical with those of Fig. 110.⁸¹

c. *Electric or Capacity Coupling.*—The mutual effect of the two condenser circuits in Fig. 113 is brought about by the *electric field* between the condenser plates. As soon as an electric field exists between the plates of C_1 , a difference of potential is produced between the plates of C_2 . Oscillations in the primary circuit therefore necessarily cause oscillations in the secondary.

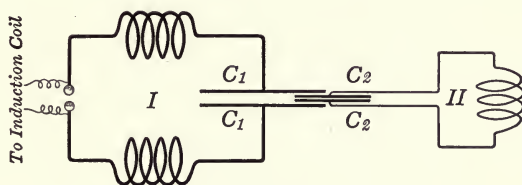

FIG. 113.

Variations of the arrangement of Fig. 113 are shown in Figs. 114 and 115, which also have electric coupling. Here, as in all practical cases, the electrical coupling consists in having one (Fig. 115) or several (Fig. 114) *condensers* common to both circuits (“*capacity*” coupling).

53. *Loose and Close Coupling.*—a. Any coupling between two circuits involves not only an action or effect of the primary upon the secondary, but also a reaction of the secondary upon the primary circuit. If the reaction is so slight as to have very little effect upon the oscillations in the primary circuit, the coupling is said to be

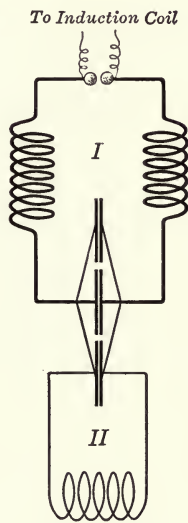

FIG. 114.

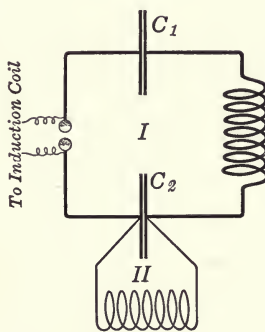

FIG. 115.

“loose,” or if the reaction is not noticeable the coupling is said to be “*extremely loose.*” If the reaction is very marked, we speak of a “*close coupling.*” A magnetic coupling becomes looser, the farther apart the two circuits are brought, other things remaining equal; a combined magnetic and galvanic (direct) coupling becomes looser, the more the portion common to the two circuits is reduced.

b. To a certain extent* the “Coefficient of Coupling” gives a measure of the extent of a magnetic coupling.

If both primary and secondary circuit have quasi-stationary current (two condenser circuits or one condenser circuit and one open oscillator, in which the current amplitude is practically the same throughout), then the coefficient of coupling

$$K = \sqrt{\frac{L_{s1_2} \times L_{s2_1}}{L_1 L_2}} = \frac{L_{s1_2}}{\sqrt{L_1 L_2}}$$

in which the coefficient of mutual induction L_{s1_2} (or L_{s2_1}) has practically the same value as for slowly changing currents.

If the current amplitude varies along different points of one of the circuits, then

$$K = \sqrt{\frac{L_{1_2} L_{2_1}}{L_1 L_2}} = \frac{L_{1_2}}{\sqrt{L_1 L_2}}$$

Here L_1 and L_2 are the respective effective coefficients of self-induction and L_{1_2} and L_{2_1} are respectively the “effective coefficients of mutual induction.” The value of the latter depends on the distribution of the current and on the point or portion at which the circuits are coupled.† The difference between L_{1_2} or L_{2_1} and L_{s1_2} or L_{s2_1} (for quasi-stationary currents) becomes less as the point of coupling comes nearer to the current anti-node and as the current distribution becomes more even.

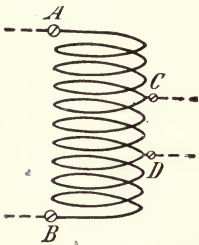

FIG. 116.

54. Methods of Coupling.⁵²

—a. Direct coupling is usually obtained by tapping off the secondary from a portion CD (Fig. 116) of a coil AB in the primary circuit or *vice versa*. If either or both the taps at

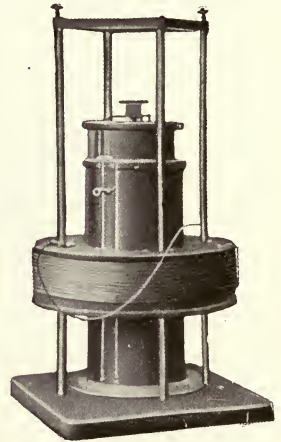

FIG. 117.

C and D are clips or sliding contacts, the coefficient of coupling can be varied in steps or continuously.

b. For magnetic coupling, the well-known “Tesla transformer,” consisting of two concentric cylindrical coils (Fig. 117) was formerly in general use. If one of the coils is *movable* (the outer coil in Fig. 117)

* See foot-note to Art. 68a.

† If the current distribution in one of the circuits is sinusoidal [Art. 18]

$$L_{1_2} = L_{2_1} = \cos \frac{2\pi x}{\lambda} L_{s1_2}$$

in which x is the distance of the point of coupling from the current anti-node and λ the wave-length of the oscillations.

a continuous variation of the coefficient of coupling may be obtained. Two flat coils, movable toward or from each other, form another coupling arrangement, convenient for the laboratory.

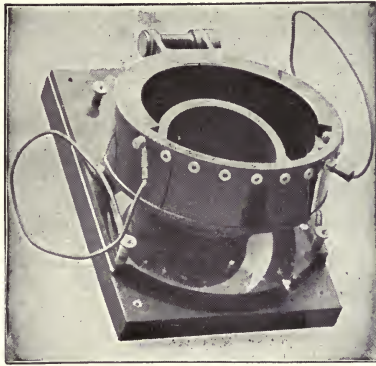

FIG. 118.

More recently, arrangements in which one of the coils can be *turned or rotated* have been preferred. All forms of variometer [Art. 38c] can



FIG. 119.

serve as such coupling devices by connecting one coil into the primary, the other into the secondary circuit. A widely used construction

(Telefunken) is shown in Fig. 118. The upper coil in the device shown in Fig. 119 (C. LORENZ) can be turned and displaced sideways at the same time.

2. LOOSE COUPLING OF DAMPED OSCILLATING CIRCUITS

55. Coupling of Oscillator to Closed Circuit.—*a.* Assume an oscillator, e.g., the condenser circuit *I*, Fig. 120, to be very loosely coupled to a closed circuit (*II*, Fig. 120). Oscillations in the condenser circuit immediately induce oscillations of the same frequency and the same damping in the closed circuit. The amplitude of the current in the closed circuit, however, instead of immediately starting at its maximum value must first rise up to its maximum, as shown for a particular case in Fig. 121.*

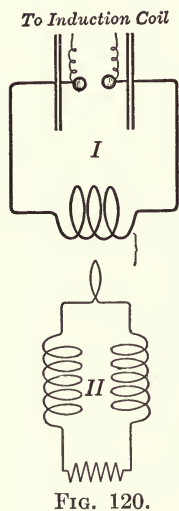

FIG. 120.

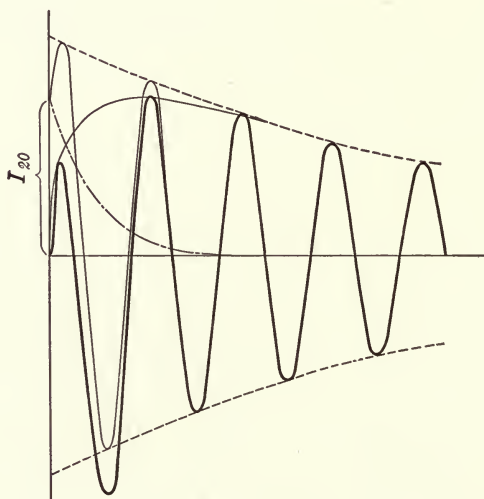

FIG. 121.

b. The arrangement of Fig. 120 finds frequent application in practice for the connection of a *measuring instrument* in the closed circuit, instead of placing it directly in the oscillator. The requirements for correct indication in such measurements are:

1. Q , the heat developed in the instrument must be proportional to Q' , the heat which would be developed in the same instrument if the latter were connected in the oscillator itself, *i.e.*,

$$Q = AQ'$$

2. The factor A must be independent of the frequency.†

* Mathematically expressed the current induced in the closed circuit $I_2 = I_{20}e^{-\frac{R}{L}t}$ (t = time, R = resistance and L = coeff. of self-induction of the closed circuit).

† The second condition is eliminated if the arrangement is used for measurements at a single frequency.

Both conditions are fulfilled, though at the expense of the current amplitude, if the inductance of the closed circuit is made very large as compared to the resistance.

c. If the coupling is loose, but not extremely loose, so that there is a slight but appreciable reaction upon the oscillator, we are justified in concluding that the reaction causes an apparent reduction of the self-induction and an apparent increase of the resistance in the oscillator. According to Art. 3 and 8*d*, this results in increased frequency and decrement.

For some purposes it is convenient to substitute an "equivalent resistance" R , for the closed circuit, under the condition that RI^2_{eff} (I = current in the oscillator) is equal to the energy transferred from the oscillator to the closed circuit per second. R increases as the coupling is made closer in the proportion $R \propto K^2$.⁸³

56. Extremely Loose Coupling of Two Oscillators (V. BJERKNES⁸⁴).—*a*. In our conception of very loose coupling, the oscillations in the primary circuit remain practically unaffected by the coupling with the secondary circuit. In the secondary there are produced in general, two distinct oscillations:

1. One having the same frequency and damping as the oscillation of the primary—the so-called "forced" or "impressed oscillation."

2. The other having the characteristic frequency and damping of the secondary circuit—the "free" or "natural oscillation."

b. The amplitudes of both the forced and natural oscillations become a maximum when the natural frequency of both primary and secondary circuits is the same, *i.e.*, when the two circuits are "tuned" or "in resonance." Then the forced and natural oscilla-

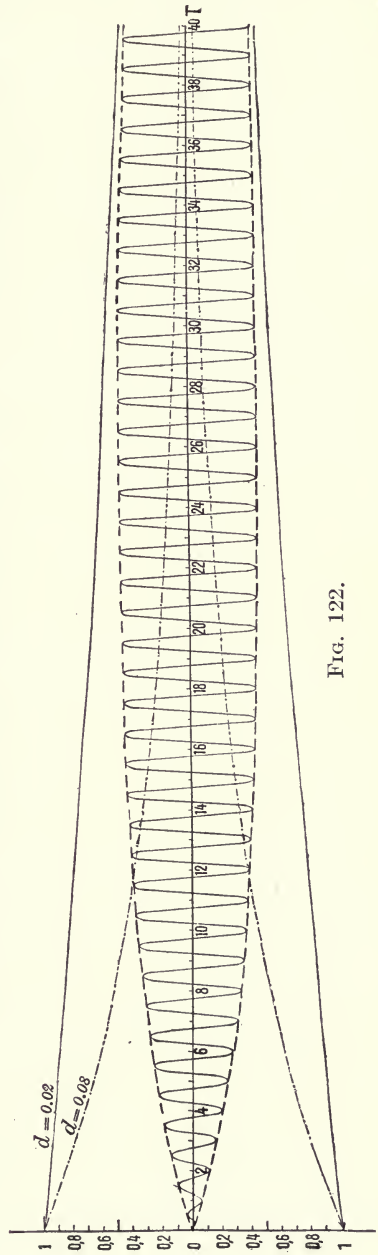

FIG. 122.

tions have the same frequency and may be considered as constituting a *single* oscillation.

The *amplitude curve* of this single oscillation, assuming that that of the primary circuit is an exponential curve, is determined as follows. First the amplitude curve of the forced oscillation (with the decrement d_1) of the primary circuit (*e.g.*, the dash and dot exponential curve in Fig. 122) is plotted, then the amplitude curve of the natural oscillation (with the decrement d_2) of the secondary circuit (*e.g.*, the full-line curve in Fig. 122) is plotted, starting the latter with the same initial amplitude as the former. Then the difference of these two curves (dashed line in Fig. 122) is the amplitude curve of the resultant oscillation.⁸⁵

In Fig. 122 $d_1 = 0.08$ and $d_2 = 0.02$, while in Fig. 123 $d_1 = 0.08$ and $d_2 = 0.2$. The former corresponds roughly to the coupling of a condenser circuit with spark gap to a condenser circuit without spark gap but containing a measuring instrument of moderate sensitiveness. The other case corresponds approximately to the coupling of a condenser circuit with spark gap⁸⁵ to a straight lineal oscillator.

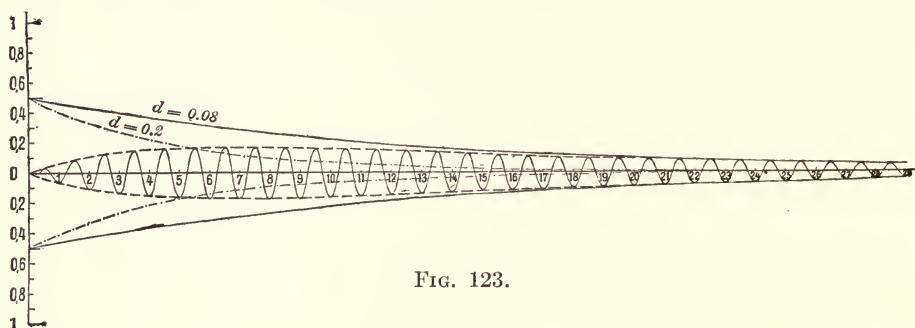

FIG. 123.

If the *decrements* of the two oscillations are widely *different*, the amplitude curve of the resultant oscillations quickly tends to become identical with that of the oscillation having the lower damping; the result, in short, is much the same as if the weakly damped oscillation alone existed. It follows that:

1. In case the primary has a much lower decrement than the secondary circuit, the oscillations obtained in the secondary will be practically as slightly damped as those in the primary.

2. In case the primary has a much higher decrement than the secondary circuit, the oscillations obtained in the latter are as slightly damped as if only the slightly damped natural oscillations of the secondary were present. The primary circuit simply serves to excite or set into motion the natural oscillations of the secondary.

- c. From the construction of the amplitude curve given in *b*, it follows that the highest value which the amplitude of the resultant oscillation can in any case assume, the so-called "maximum amplitude" (I_{max}),

can never be greater than the amplitude I_0 of the impressed oscillation. For the latter with two circuits having quasi-stationary* currents,⁸⁵ we have:

$$I_0 = \pi \cdot \frac{L_{s21}}{L_2(d_1 - d_2)} I_{10}$$

and for the maximum amplitude:

$$I_{max} = \frac{\pi}{d_2} \cdot \left(\frac{d_1}{d_2}\right)^{\frac{d_1}{d_2 - d_1}} \cdot \frac{L_{s21}}{L_2} I_{10}$$

57. Loose Coupling of Two Oscillators (M. WIEN).⁸⁶—If the coupling is not extremely loose, yet sufficiently loose to make $K^2 < \left(\frac{d_1 - d_2}{2\pi}\right)^2$, a slight reaction becomes noticeable. Consequently there is a change in the *damping* of the two oscillations. The decrement of the more weakly damped oscillation is increased and that of the more highly damped oscillation is reduced, that is the two decrements come nearer to each other in value.

The following are the equations for the new decrements d^I and d^{II} with primary circuits having *no spark gap*:

$$\left. \begin{aligned} d^I &= \frac{1}{2}(d_1 + d_2 + 2\pi K_1) \\ d^{II} &= \frac{1}{2}(d_1 + d_2 - 2\pi K_1) \end{aligned} \right\} K_1^2 = \left(\frac{d_1 - d_2}{2\pi}\right)^2 - K^2$$

or, as long as K is small as compared to $\frac{d_1 - d_2}{2\pi}$

$$\begin{aligned} d^I &= d_1 + \frac{\pi^2 K^2}{d_2 - d_1} \\ d^{II} &= d_2 - \frac{\pi^2 K^2}{d_2 - d_1} \end{aligned}$$

3. CLOSE COUPLING OF TUNED, DAMPED OSCILLATING CIRCUITS

58. Form of the Oscillations.—Assume two tuned oscillators, say two condenser circuits, which before coupling had the frequency N and wavelength λ and the respective decrements d_1 and d_2 , to be coupled. The coupling is not made loose, so that in any case

$$K^2 > \left(\frac{d_1 - d_2}{2\pi}\right)^2 \dagger$$

* For currents not quasi-stationary L_{s21} should be replaced by L_{21} in the equations for I_0 and I_{max} , which latter are to be understood as values at the current anti-nodes.

† In the very unfavorable case of $d_1 = 0.08$, $d_2 = 0.2$, K must > 0.02 to meet this condition; for $K > 0.1$, K' becomes practically identical with K in all cases encountered in actual practice.

whence

$$K'^2 = K^2 - \left(\frac{d_1 - d_2}{2\pi}\right)^2 > 0 \quad (1)$$

Whenever the coupling is fairly close, K^2 is considerably greater than $\left(\frac{d_1 - d_2}{2\pi}\right)^2$, so that the quantity K' is not much different from the coupling coefficient K . (See note †, p. 87.)

Under these conditions there are in general⁸⁷ **two distinct oscillations** the so-called "**coupling oscillations**" ("**coupling waves**") produced *in both the primary and the secondary circuit*, having *two distinct frequencies*, N^I and N^{II} , and *two distinct decrements*, d^I and d^{II} .

If, as heretofore, we use I_1 and V_1 to indicate current and voltage in the primary circuit, I_2 and V_2 the same in the secondary then I_1 (and V_1) as well as I_2 (and V_2) are the results of two oscillations. Hence we may write:

$$\left. \begin{aligned} I_1 &= I_1^I + I_1^{II} \\ V_1 &= V_1^I + V_1^{II} \end{aligned} \right\} \text{for the primary circuit.}$$

$$\left. \begin{aligned} I_2 &= I_2^I + I_2^{II} \\ V_2 &= V_2^I + V_2^{II} \end{aligned} \right\} \text{for the secondary circuit.}$$

The various oscillations have the following frequencies, wave-lengths and decrements.

$$\left. \begin{aligned} I_1^I \text{ (and } V_1^I) \\ I_2^I \text{ (and } V_2^I) \end{aligned} \right\} N^I, \lambda^I \text{ and } d^I.$$

$$\left. \begin{aligned} I_1^{II} \text{ (and } V_1^{II}) \\ I_2^{II} \text{ (and } V_2^{II}) \end{aligned} \right\} N^{II}, \lambda^{II} \text{ and } d^{II}.$$

59. The Frequency of Coupling Waves.—*a. Primary Circuit without Spark Gap.*—Let the index I refer to the oscillation having the higher frequency and shorter wave-length. Then we have:

$$\left. \begin{aligned} N^I &= \frac{N}{\sqrt{1 - K'}} \\ N^{II} &= \frac{N}{\sqrt{1 + K'}} \end{aligned} \right\} \frac{N^I}{N^{II}} = \sqrt{\frac{1 + K'}{1 - K'}} \quad (1)$$

and

$$\left. \begin{aligned} \lambda^I &= \lambda \sqrt{1 - K'} \\ \lambda^{II} &= \lambda \sqrt{1 + K'} \end{aligned} \right\} \frac{\lambda^I}{\lambda^{II}} = \sqrt{\frac{1 - K'}{1 + K'}} \quad (2)$$

Hence, the greater K' , *i.e.*, the closer the coupling, the more will the frequencies (wave-lengths) of the coupling waves differ from each other and from the original common frequency (wave-length).

b. Primary Circuit with Spark Gap.—In this case also the relations between the frequencies before and after coupling are of the form of equations (1). It is not definitely known, however, though this is of no prac-

tical importance, whether the factor K' has the relation to the coefficient of coupling, K , and the decrements given by equation (1) of Art. 58. The quantity which actually determines the extent of the coupling and which may be directly measured by test [Art. 87] is the factor K' for circuits with spark gap also.

K' is called the "degree of coupling." Its value is frequently expressed in percentage, thus: "3 per cent. coupling" means $K' = 0.03$. The relation between N^I , N^{II} and N , as well as λ^I , λ^{II} and λ is given in Table X for different values of K' .

c. The *resultant oscillation* produced from the two coupling oscillations of different frequency is of the form shown diagrammatically in Fig. 130, and shown in Fig. 124 as obtained with an oscillograph (H. DIESELHORST⁸⁸) and in Fig. 125 as photographed from the spark discharges (H. RAU⁸⁸). The resultant oscillation may be conceived as having the frequency N and an amplitude which periodically increases and decreases, similarly to the *beats* or *pulsations* of a tone which are observed in acoustics.



FIG. 124.



FIG. 125.

The greater the difference between the frequencies of the two oscillations, *i.e.*, the closer the coupling, the greater is the number of pulsations obtained per second. This number, S , which is the number of times per second that the amplitude passes through zero, is given by

$$S = N^I - N^{II} = \text{approx. } NK'$$

Hence the duration of one beat or pulsation is approximately $= \frac{1}{NK'}$ seconds $= \frac{1}{K'}$ periods.

d. The *energy relations*, as is evident from Fig. 130, are as follows: Originally the entire energy resides in the primary circuit. After half of one pulsation the amplitude of the oscillation in the primary circuit is

zero, while that in the secondary is a maximum and the entire energy has been transferred to the secondary circuit. After another half pulsation all the energy is again back in the primary and the secondary is at zero, etc., etc. In short, the energy continues to swing back and forth between the primary and secondary circuits.

60. The Decrements of the Coupling Waves.—*a. Primary Circuits without Spark Gap* (P. DRUDE⁸⁹).—The relations of the decrements before and after coupling are expressed by:

$$\left. \begin{aligned} d^I &= \frac{d_1 + d_2}{2} \cdot \frac{N^I}{N} = \frac{d_1 + d_2}{2} \cdot \frac{\lambda}{\lambda^I} \\ d^{II} &= \frac{d_1 + d_2}{2} \cdot \frac{N^{II}}{N} = \frac{d_1 + d_2}{2} \cdot \frac{\lambda}{\lambda^{II}} \end{aligned} \right\} \begin{aligned} d^I &= \frac{N^I}{N} = \frac{\lambda^I}{\lambda} \\ d^{II} &= \frac{N^{II}}{N} = \frac{\lambda^{II}}{\lambda} \end{aligned}$$

So that while for low degrees of coupling the decrements of the two oscillations are approximately equal to the average value of the decre-

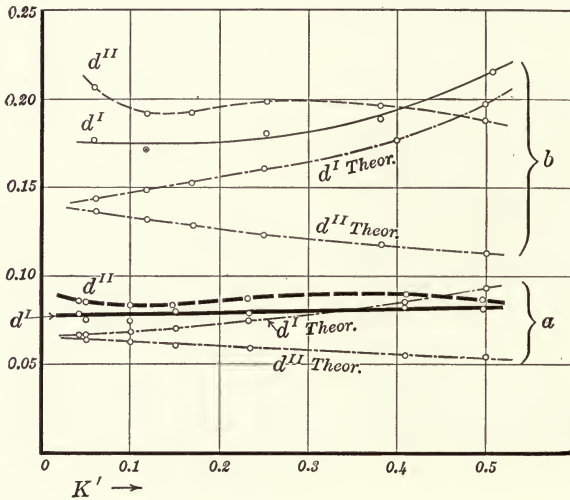

FIG. 126.

ment before coupling, as the coupling becomes closer, the decrement of the oscillation having the shorter wave-length increases and that of the oscillation having the longer wave becomes less than the average value mentioned above.

Theoretically the closest possible coupling exists when $K' = 1$; in practice about the highest value obtainable is approximately $K' = 0.6$. For this latter value, we have:

$$\begin{aligned} N^I &= 1.6 N & d^I &= 0.8 (d_1 + d_2) \\ N^{II} &= 0.8 N & d^{II} &= 0.4 (d_1 + d_2) \end{aligned}$$

Hence in practice the frequency and decrement of the oscillation of shorter wave-length will at most be twice what they are for that of the longer wave.

b. *Primary Circuit with Spark Gap.*—(C. FISCHER⁹⁰).—In this case the relations of *a* do not hold.

1. The decrements of both oscillations, particularly if the coupling is loose, are greater than would follow from *a*.

2. It is by no means always the oscillation of shorter wave-length which is the most highly damped. *On the contrary, this usually is more slightly damped than the oscillation of greater wave-length.*

The conditions obtained by coupling a condenser circuit containing a spark gap with another having no gap, were observed by C. FISCHER, whose results are shown in Figs. 126 and 127. Fig. 126 refers to the case of primary and secondary capacities being practically equal* while

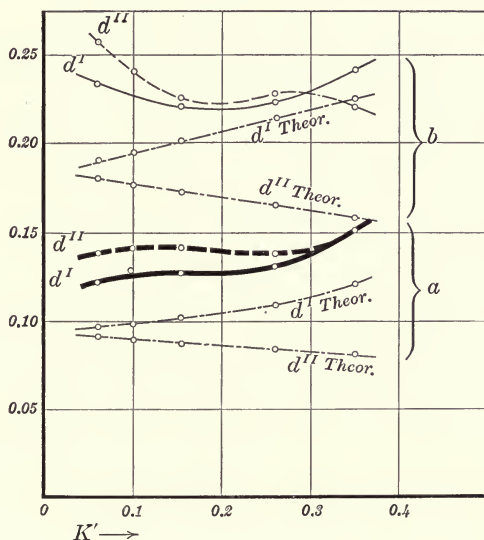

FIG. 127.

in Fig. 127† the capacity in the primary circuit is much greater than that in the secondary.

61. Amplitude and Phase of the Oscillations.⁹¹—*a. Amplitude.*‡—The current amplitudes of the individual oscillations have the same relation, approximately, as their frequencies, *i.e.*,

$$\frac{I}{I_{10}} = \frac{I}{I_{20}} = \frac{N}{N} = \frac{\lambda}{\lambda}$$

* $C_1 = C_2 = 0.85 \times 10^{-3}$ MF. $L_1 = L_2 =$ approx. 22,000 C.G.S. Length of gap = 6 mm.

† $C_1 = 5.29 \times 10^{-3}$ MF. $L_1 = 6230$ C.G.S. Gap = 6.8 mm. approx. $C_2 = 0.45 \times 10^{-3}$ MF. $L_2 = 73,000$ C.G.S.

‡ If the current in one of the circuits is not quasi-stationary, the current amplitude is to be understood as the value at the current anti-node.

The current amplitude of the oscillation having the shorter wave-length is therefore greater than that of the longer wave oscillation.

Assume a given known value for the initial potential V_{1_0} of the primary circuit, then we have the following expressions for the current and voltage amplitudes in a secondary circuit having quasi-stationary current:*

$$V_{2_0}^I = V_{2_0}^{II} = \frac{1}{2} \sqrt{\frac{C_1}{C_2}} \cdot V_{1_0} = \frac{1}{2} \sqrt{\frac{L_2}{L_1}} \cdot V_{1_0}$$

$$\bar{I}_{2_0}^I = \pi N^I \sqrt{C_1 C_2} \cdot V_{1_0} = \sqrt{\frac{C_2}{C_1}} \cdot I_{1_0}^I = \sqrt{\frac{L_1}{L_2}} \cdot I_{1_0}^I$$

$$I_{2_0}^{II} = \pi N^{II} \sqrt{C_1 C_2} \cdot V_{1_0} = \sqrt{\frac{C_2}{C_1}} \cdot I_{1_0}^{II} = \sqrt{\frac{L_1}{L_2}} \cdot I_{1_0}^{II}$$

b. *Phase.*—If we consider as positive the direction of the oscillating current I (one) in both circuits, the vector diagram will have the form of Fig. 128. The angles of phase displacement φ^I and φ^{II} are given approximately by

$$\tan \varphi^I = \frac{d_2 - d_1}{2\pi} \cdot \frac{1}{K'} \cdot \frac{N}{N^I}$$

$$\tan \varphi^{II} = \frac{d_2 - d_1}{2\pi} \cdot \frac{1}{K'} \cdot \frac{N}{N^{II}}$$

In all practical cases, as long as the coupling is fairly close† these angles are very small. We may therefore state roughly: of the oscillations in the primary and secondary circuits having the same frequency, the

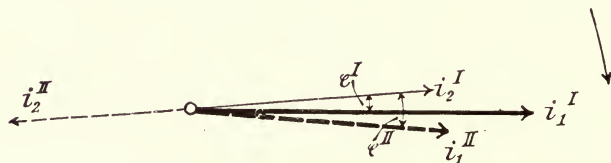

FIG. 128.

one pair (I_1^I , and $I_2^{I\dagger}$) are almost in phase, while the other pair (I_1^{II} and $I_2^{II\dagger}$) are approximately 180° apart.

c. The maximum amplitude of the resultant oscillation in the secondary circuit depends not only upon the amplitude of the two component oscillations, but also upon their phase and damping.

* If neither primary nor secondary circuit has quasi-stationary current, these relations, to the extent of their involving the voltage, hold only approximately; those independent of V_{1_0} are correct if the value of the current anti-node is taken as the current amplitude.

† Assume $d_1 = 0.08$ and $d_2 = 0.2$; then K' need only be large as compared to 0.02. If the secondary circuit is less damped the conditions become still more favorable.

‡ i is used in Fig. 128 instead of the capital I .

If the primary circuit contains *no* spark gap, we have, for quasi-stationary current in the secondary (P. DRUDE⁸⁹):

$$V_{2max} = f \sqrt{\frac{C_1}{C_2}} \cdot V_{1_0} = f \sqrt{\frac{L_2}{L_1}} \cdot V_{1_0}$$

$$I_{2max} = 2\pi Nf \sqrt{C_1 C_2} \cdot V_{1_0}$$

in which f is a factor which depends upon the sum of the decrements previous to coupling, $d_1 + d_2$, and upon the degree of coupling as shown in Fig. 129.

For primary circuits *with* a spark gap these curves for f are somewhat different. The difference, so far as this question has been investigated

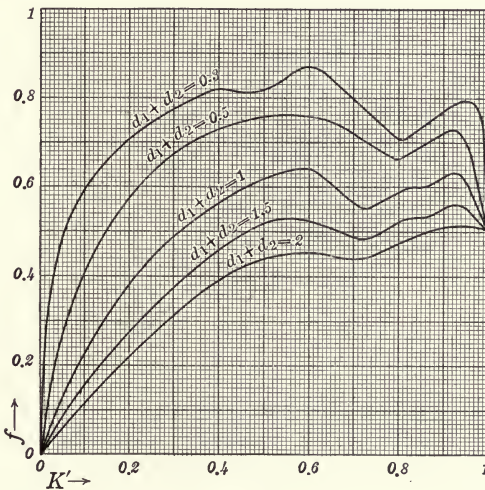

FIG. 129.

to date (J. ZENNECK^{91a}, C. FISCHER⁹⁰), seems to consist mainly in that the curves have either a true maximum or at least do not increase beyond the value reached between $K' = 0.2$ and $K' = 0.4$.

4. QUENCHING ACTION IN COUPLED CIRCUITS (M. WIEN⁹²)

62. Form of the Oscillations.—In Art. 59 it was stated that under the conditions therein specified the oscillations in the primary and secondary circuits would be of the nature illustrated in Fig. 130.* In the primary circuit, after lapse of half a pulsation, the amplitude of the oscillation is zero or nearly zero. It then increases again, this being due to the fact that the secondary, whose amplitude is at its maximum at that moment, induces an EMF in the primary, producing a difference of potential between the electrodes of the spark gap.

* Assumption: $d^I = d^{II} = 0.08$; $K' = 0.16$.

The conditions may be such, however, that the spark gap, during the time in which the amplitude in the primary circuit is very small, becomes

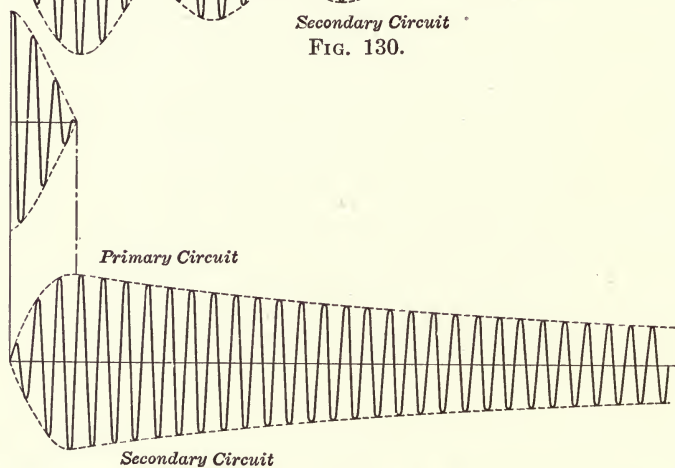
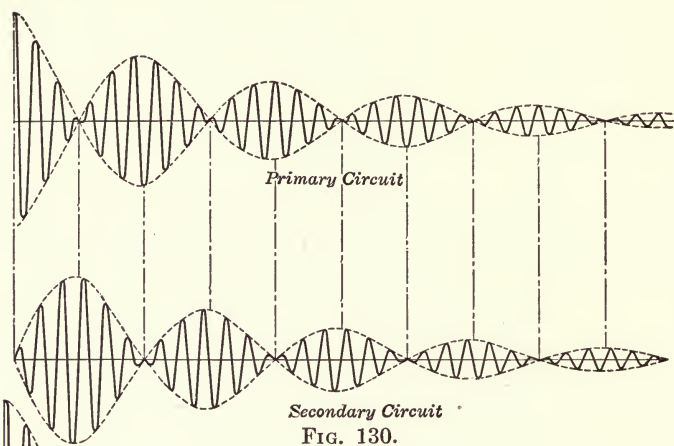

so deionized, that the EMF induced by the secondary is no longer sufficient to start or "ignite" a spark discharge across the gap. As a result the spark gap remains quenched—whence the terms "quenching

action" or "quenched gap." The oscillations in the primary then discontinue entirely and the secondary circuit continues to oscillate with its natural damping and at its natural frequency just as if the primary circuit did not exist. (Compare the diagrammatic Fig. 131* and the spark photograph Fig. 132 [H. RAU⁸⁸].)

63. Various Types of Quenched Gaps.—*a. Very short metallic spark gaps* (M. WIEN) are of special importance in practice.

Not only the *material* of which the electrodes are made but also the *gas* in the gap between them is of importance. Particularly good quenching action is obtained with silver and copper, aluminium is less satisfactory and zinc, tin and magnesium do not give good quenching (M. WIEN⁹²); platinum-iridium alloy is also quite effective with short gap lengths (H. BOAS⁹³). The quenching action is increased if the sparks are passed through *hydrogen* instead of air (A. Espinosa de los Monteros⁹⁴) †

b. For laboratory purposes the so-called *mercury-arc lamp*, *i.e.*, an exhausted glass tube with mercury electrodes (R. RENDAHL⁹⁵) is very well adapted. Apparently the only essential element in the form of this lamp is the provision of a sufficiently large space over the electrodes for cooling and condensing the mercury vapor. Moreover the tube must have a high vacuum and pure mercury must be used.

c. With primary circuits having long gaps, which in themselves would have no quenching action, it is possible to secure quenching by greatly increasing the damping of the primary circuit through an inserted resistance, or better still, by inserting a glass tube filled with gas at very low pressure (*e.g.*, 3 mm. mercury) and having metallic electrodes—a so-called "quenching tube" (M. WIEN⁹²).

64. Requirements for Good Quenching.—*a. Time-lapse of One Pulsation.*—In view of the fact that the primary circuit consumes less energy the sooner the oscillations in it are quenched, ‡ *i.e.*, for the sake of efficiency, it is desirable to make the coupling as close as possible. The closer the coupling, the shorter will be the time-lapse or duration of one pulsation, which is the time during which the primary circuit remains active [59c].

On the other hand, however, the time during which the amplitude in the primary remains very small and, hence, the time during which the spark gap is subjected to deionization becomes shorter as the coupling is made closer. If this time is made too short, "pure" quenching is no longer obtained, *i.e.*, the primary oscillation is not suppressed after one-half a pulsation. Either coupling oscillations result or intermediate conditions between distinct coupling oscillations and pure quenching

* Assumption: $d_2 = 0.03$; otherwise just as for Fig. 130.

† In regard to hydrogen quenched spark gaps [see Art. 109c].

‡ For the same decrement; this also affects the efficiency [b].

are obtained; thus the primary oscillations disappear only after one and one-half or two and one-half pulsations (Fig. 133, H. RAU⁸⁸).

Hence close coupling is desirable for efficiency, while loose^{95a} coupling is needed for pure quenching. It follows that for every spark gap there must exist a "**critical degree of coupling**," at which pure quenching is still just obtainable. This is of course always used in order to secure as high efficiency as possible. The higher the critical percentage of coupling, the better will be the quenching action of the given spark gap.

b. Pureness of the Pulsations.—It is most favorable for the quenching action if the amplitude of the resultant oscillation in the primary circuit really becomes zero after the first half pulsation, that is, if the pulsations are *pure*. The essential condition for this, however, is that both oscillations, after half a pulsation, have the same amplitude but are opposite in phase.

Whether this condition obtains depends upon the accuracy of the tuning between the primary and secondary circuits; the more exact the tuning, the purer will be the pulsations, other things being equal.

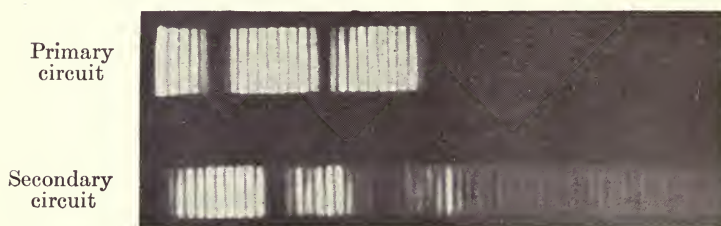

FIG. 133.

Moreover, even with perfect tuning, it is evident that the pureness of the pulsations depends upon the initial amplitude of the two oscillations and their *decrements*. In this connection, therefore, the decrement of the primary and secondary circuits becomes of importance. As the decrements of the coupling oscillations also depend on the degree of coupling, the latter affects the quenching action in this way also.

Apparently this effect of the degree of coupling plays a part in connection with the following phenomenon (H. RIEGGER⁷). If the degree of coupling is gradually increased a *first* critical coupling is reached, beyond which pure quenching is no longer attainable. If, however, we proceed to make the coupling much closer, a degree of coupling is reached at which pure quenching is again obtained (*second* critical percentage of coupling). In fact, under certain conditions, a *third* critical coupling may occur. The critical degree of coupling of a quenched gap is therefore by no means always a single definite quantity.

The pureness of the pulsations probably also plays a part in the explanation of the fact that by bringing the primary and secondary cir-

cuits slightly out of resonance, a pure quenching can be obtained, after the quenching had been spoiled with primary and secondary entirely in tune (H. RIEGGER⁷).

c. The magnitude of the EMF induced in the primary by the secondary circuit is also affected by the degree of coupling; in fact, is proportional to the coefficient of coupling, other things being equal. Hence the greater the coefficient, so much greater is the danger that a discharge will pass across the spark gap after half a pulsation.

d. Lastly, the *temperature of the electrodes*, that is, not the average temperature, but the maximum at any point (*local heating*) affects the quenching, as when the temperature becomes very high the gas is highly ionized, thereby greatly reducing the quenching action as well as the discharge voltage. This makes it easier for another spark to jump across the gap after the first half pulsation. Hence, care must be taken that the temperature does not rise too high at any part of the gap electrodes.⁹⁶

65. Concerning the Nature of the Quenching Action.—*a.* The general requirement for the best quenching action is identical with the requirement for the quickest possible deionization of the spark gap. The deionization may have several causes, viz.:

1. The *recombining* of the positive and negative ions; when two ions of opposite charge collide, this may result in a neutralization of their charges.

2. *Diffusion* of the ions from the gap space between the electrodes into space without; just as a gas (*e.g.*, illuminating gas), pouring out from some opening will spread out in all directions (diffuse) in the surrounding medium (*e.g.*, air), so the ions diffuse from the space in which they were formed into the surrounding gas.

3. *Absorption* of the ions at the gap electrodes. If an ion comes close to a piece of metal, the latter will have the same effect upon it as any uncharged conductor has on a charged body, viz., an attractive force. Consequently the ion comes into contact with the metal and gives its charge up to it.

This last kind of deionization is also influenced by the diffusion of the ions. The faster new ions are diffused from the outer space to the surface of the gap electrodes, the quicker will deionization take place, corresponding to a greater coefficient of diffusion.*

4. *Deionization by the Electric Field between the Gap Electrodes.*—If an electric field exists between the gap electrodes, the positive ions are attracted to the negative electrode, the negative ions to the positive electrode, where they give up their charge. In the case in point a field

* The coefficient of diffusion D is defined as follows: If c' is the concentration factor (= change in the number of ions present in 1 cc., along a length of 1 cm.), then the number of ions diffused through a section 1 cm. sq. per sec. is Dc' .

exists between the gap plates both before and after the moment at which the amplitude of the oscillation in the primary is zero. The field existing after the zero amplitude is induced by the oscillations in the secondary circuit.

5. *Deionization by Chemical Changes.*—The conductivity of the gap is due mainly to the ions of the metallic vapor formed by the heating of the electrodes. It is possible that deionization results from a chemical combination of the metallic vapor and the gas in the gap. These changes, however, are at present but little understood.

b. With *short metal spark gaps* deionization through recombination and diffusion of the ions in the outer space can hardly play an important part. This is borne out by the facts that the quenching action increases very rapidly with decreasing distance between the electrodes and that it is particularly good in spark gaps having plate or disc electrodes arranged to make diffusion into the outer space very difficult.

Here then—aside from possible chemical action—the deionization must result mainly from the electric field and absorption.

If v is the mean specific velocity of an ion, *i.e.*, the velocity which it obtains in an electric field of 1 volt/cm., then the ^{voltage!} \underline{V} velocity, V , required to move the ion over a distance d between the electrode in one-half a period = $\frac{d^2}{v} \cdot 2N$. Hence, V being proportional to the square of d , would be only one-hundredth in value for $d = 0.1$ mm., what it would be for $d = 1$ mm. Taking the normal value of \mathcal{V} at atmospheric pressure as 1.5 cm./sec., taking 0.1 mm. as the distance between the electrodes (gap length) and the frequency $N = 3 \times 10^8$ /sec., which corresponds to a wave-length of 1000 meters, V is found to be 40 volts; for a wave-length of 3000 m., V is only 13 volts. Hence under these conditions very low voltages suffice to produce complete deionization within one-half a period.

Similarly the time required to reduce the number of ions between the electrodes to a given fraction of the original number is reduced as the gap length is decreased.*

From the foregoing, it is easily comprehensible that the quenching action of gaps increases very rapidly as the gap length decreases, and that series spark gaps [Art. 12] have a decided advantage in this respect over a single gap of the same initial voltage (*A. Espenosa de los Monteros*⁹⁴): a series gap of ten units each 0.1 mm. long must be much more effective than a single gap 1 mm. long. Presumably, this deionization by means of the electric field of the discharge, perhaps also in conjunction with the absorption, is the cause of the very high spark decrement [Art. 11*d*] characteristic of metallic spark gaps and explains the ease⁹⁷ with which the oscillations are abruptly discontinued in such gaps [Art. 9*d*].

c. The effectiveness of *hydrogen* as the gap medium, and also of gases under low pressure (quenching tubes) may be explained on the assumption that either diffusion or deionization by the electric field is the principal

* This time $\propto d$ or $\propto d^2$ (d = gap length) in accordance with original distribution assumed for the ions.

cause. The coefficient of diffusion for hydrogen is about four times that for air under the same conditions; furthermore, it is inversely proportional to the pressure. However, very much the same is true of the specific velocity of the ions.*

5. THE COUPLING OF UNDAMPED OSCILLATING CIRCUITS

66. **Coupling with a Closed Circuit.**—In a closed circuit coupled loosely to a circuit with undamped oscillations, there will also be obtained undamped oscillations. Immediately upon starting, however, the same complications described for damped oscillations [Art. 55] arise.

But in contrast to the conditions holding for damped oscillations, the indications of a measuring instrument connected into the closed circuit

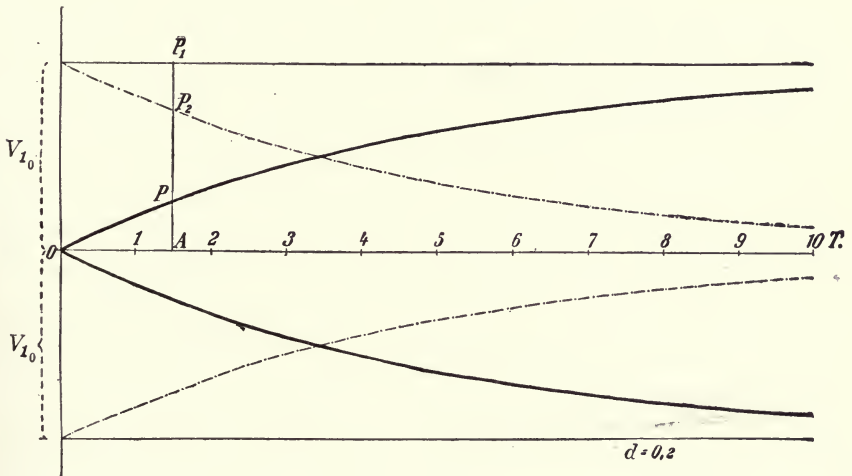

FIG. 134.

will not be affected by these complications when the oscillations are undamped. It is assumed that the oscillations are sinusoidal and that the heat, Q , developed in the instrument is *always* proportional to the heat, Q' , which would be developed in the same instrument if it were connected directly into the primary circuit. That is

$$Q = AQ' \text{ always.}$$

Here, just as for damped oscillations, the inductance of the closed circuit must be large in comparison to its resistance to make the proportionality factor A independent of the frequency.

* The good heat conductivity of hydrogen probably comes into secondary consideration only, in that it causes a more rapid cooling of the gap electrodes and the metallic vapors.

67. Loose Coupling with an Oscillator.—*a.* As with damped oscillations [Art. 56] two oscillations are obtained in the secondary circuit, viz.:

1. A forced or impressed oscillation of the same frequency as the primary.

2. The damped natural oscillation of the secondary circuit.

b. The *amplitudes* of both oscillations are a *maximum* when the *secondary is in resonance with the primary circuit*. Then both oscillations may be considered as a single resultant oscillation.

What was stated in regard to the *amplitude curve* for damped oscillations [Art. 56*b*] holds equally well here; the relations, however, are now somewhat simpler as the amplitude curve of the impressed oscillation is a straight line. The construction is shown for a given case, Fig. 134,* the oscillation curves being drawn out in Fig. 135.*

As may be seen from these curves, the amplitude in the secondary first increases gradually from zero. The time required for this increase up to the final maximum value is the time required for the natural oscillation to die out, hence is longer for low than for high damping. But the less the damping, so much greater will be the final value of the amplitude, the latter

being inversely proportional to the decrement. This final current amplitude after the natural oscillation has disappeared has the following value:

* Impressed oscillation: thin full line, natural oscillation: dot and dash line, resultant oscillation: heavy full line.

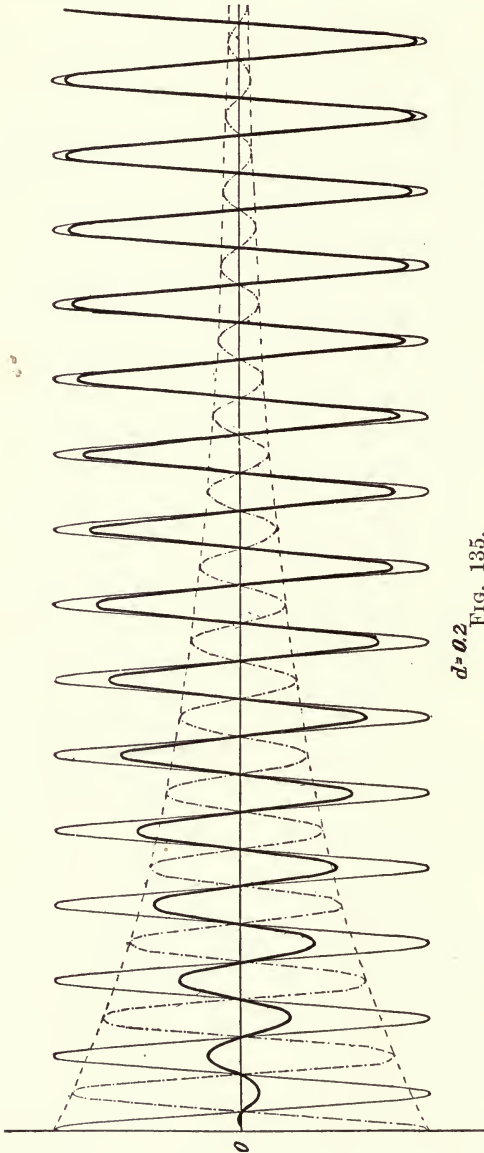

$d = 0.2$
Fig. 135.

$$I_{2_0} = \frac{E_{a_0}^*}{R_2} = \omega L_{s2_1} \cdot \frac{1}{R_2} I_{1_0} = \pi \frac{L_{s2_1}}{L_2} \cdot \frac{1}{d_2} \cdot I_{1_0} \quad (\text{See foot-note to Art. 52a.})$$

Fig. 136 shows the curve for a decrement of 0.8 under the same conditions and on the same scale as Fig. 135 in which, however, the decrement is 0.2. The impressed oscillation is in phase with E_a .

c. The final amplitude reached by the oscillation in the secondary circuit is much greater than it would be if the secondary and primary circuits were not in resonance or if the secondary were a closed circuit. This is explained as follows: With loose coupling only very little energy is transferred from the primary to the secondary during each period or cycle. But only a part of this energy is dissipated in the secondary, the rest being *stored* by it. Consequently the energy accumulated in the secondary circuit grows with each period. This continues until, due to the increasing amplitude, the energy loss in the secondary has become equal to the energy supplied by the primary circuit. This point is reached more quickly, the greater the energy consumption in the secondary circuit is in comparison to energy supplied, *i.e.* [Art. 8d] the greater the decrement is.

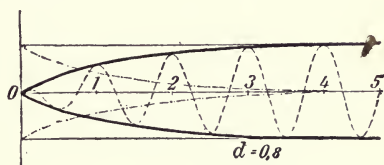

FIG. 136.

68. Close Coupling with an Oscillator.—It is very difficult to draw any general conclusions in this connection with close coupling. For undamped oscillations can be produced in a primary circuit only by constantly replenishing the energy consumed by the oscillations, and the results depend to a large extent upon *how this supply of energy is affected by the reaction of the secondary circuit.* †

a. In the simplest case the energy supply is such as to maintain a *constant current amplitude* in the primary circuit. Then the conditions in the secondary are just the same as with loose coupling. ‡

This can be secured by connecting the primary winding of an induction coil to the terminals of an alternator through a *very high* series resistance, and connecting condensers to the secondary of the induction coil; the condensers and induction coil secondary form the secondary circuit. If the series resistance is sufficiently great in comparison to the impedance of the primary of the induction coil, then the amplitude of the primary current, being determined almost entirely by the series resistance, remains unaffected by the reaction of the secondary circuit.

b. In the second case, which is of far greater importance in practice,

* $E_a = EMF$ induced in the secondary by the primary circuit.

† In regard to the arc method of coupling undamped oscillations see S. SUBKIS^{97a}.

‡ Actually there is a slight reaction of the secondary here too, even though the coefficient of coupling may be quite high under certain conditions. In such cases the coefficient of coupling gives no correct measure of the reaction.

the external (impressed) electromotive force is maintained at constant amplitude and frequency.⁹⁸ These are the conditions existing, at least approximately, when the primary of a transformer or an induction coil is joined to the terminals of an alternator, driven by a sufficiently strong motor, while the transformer or induction coil secondary is connected to condensers.

The initial increase of the amplitude is the same qualitatively as with loose coupling [Art. 67] or as in case *a*.

But there is one great difference. If the secondary frequency is varied by changing the condensers, then the amplitude of the oscilla-

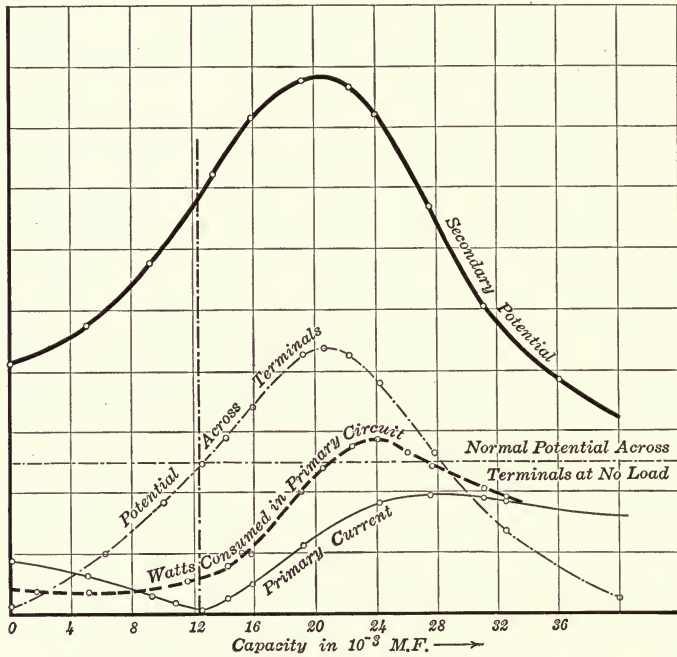

FIG. 137.

tions in the secondary circuit does not become a maximum when the natural oscillations of the secondary have the same frequency as that of the primary circuit. The maximum is obtained at a secondary frequency which is lower than that of the primary and the closer the coupling, the lower will be the frequency at which the maximum amplitude of the secondary oscillations occurs.* This is due to the simple fact that the primary current and hence also the energy supply are by no means constant, but are much greater at the lower frequency under the influence of the reaction of the secondary circuit.

* Within certain limits we may write for N_r , the frequency at which the amplitude is a maximum, approximately

$$N_r = N_1 \sqrt{1 - K^2} \quad (K = \text{coefficient of coupling})$$

This is shown by the curves of Fig. 137, taken from an article by G. GLAGE.⁹⁸ The values of the capacity in the secondary circuit are plotted as abscissæ, while the ordinates represent what is marked over each curve. The vertical dot and dash line indicates the capacity at which the natural oscillations of the secondary have the same frequency as the primary.

69. Difference between Damped and Undamped Oscillations.—

a. Looking back over the ground just covered it appears that undamped oscillations are by no means much simpler in their various relations than damped oscillations. To be sure an undamped oscillation is always obtained in the secondary circuit. But at the start, exactly the same complications arise as with damped oscillations. These complications are:

1. Secondary = a closed circuit:— a current of the form [Art. 55a]

$$I = I_0 e^{-\frac{R}{L}t} \quad (t = \text{time})$$

2. Secondary = oscillator:—damped oscillations [Art. 67 and 68].

3. Secondary = circuit with capacity and self-induction, but such high resistance that real oscillations cannot take place:—current of the form⁹⁹

$$I = I_0(e^{-a_1 t} - e^{-a_2 t})$$

or, in case the coefficient of self-induction is very small

$$I = I_0 e^{-\frac{1}{CR}t} \quad 100$$

Hence, considered from the initial conditions, the phenomena are no simpler for undamped than for damped oscillations.

b. For making *measurements* however the conditions are quite different. These disturbances are all of such short duration that they disappear in a few seconds at the very most, in fact within a few thousandths or even millionths of a second in most practical cases.

Hence, with *undamped* oscillations these disturbances have long disappeared before the instrument shows an appreciable deflection. Only the subsequent undisturbed oscillations determine the indications of the instrument.

With damped oscillations, on the other hand, the time during which these phenomena which we have designated as disturbances take place may be of considerable importance in relation to the duration of the primary oscillations, in fact they may last even longer than the latter [Art. 56b2]. Just as often as the primary oscillations are again set into motion, so often will these "disturbances" reappear. The heat developed in a measuring instrument will therefore depend upon these disturbances as well as upon the oscillations induced by the primary circuit, and the relations may become far more complicated than with undamped oscillations.

CHAPTER V

RESONANCE CURVES¹⁰¹

1. THE RESONANCE CURVE OF THE CURRENT EFFECT

70. General Remarks.—Assume two oscillators loosely coupled and let the frequency be varied in one of them. Let the current effect in the secondary circuit be determined by any suitable instrument and let there be a *constant number of discharges per second*. Plot the observed current effects, I_{eff}^2 , as ordinates and the corresponding frequencies, N_2 , or wave-lengths, λ_2 , as abscissæ. The curve thus obtained is called the “**resonance curve of the current effect.**” Theoretically its equation is

$$I_{eff}^2 = \zeta \cdot \frac{\mathcal{E}_{a_0}^2}{64\pi^2 N_1^3 L_2^2} \cdot \frac{d_1 + d_2}{d_1 d_2} \cdot \frac{1}{\left(1 - \frac{N_2}{N_1}\right)^2 + \left(\frac{d_1 + d_2}{2\pi}\right)^2} \quad (1)^*$$

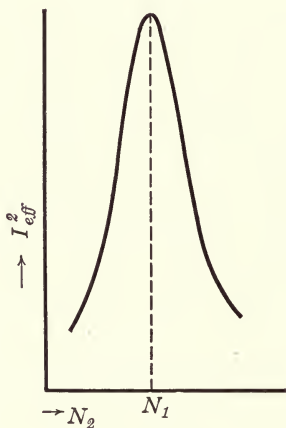

FIG. 138.

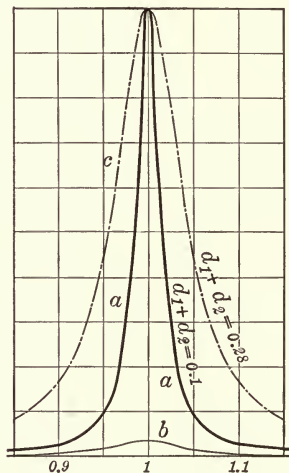

FIG. 139.

which is based on the assumption that the amplitude curve of the primary is an *exponential curve* and that both d_1 and d_2 are $\ll 2\pi$.

a. The character of these resonance curves may be seen from that shown in Fig. 138. At the point $N_2 = N_1$ ($N_1 =$ frequency of the unchanged circuit) the curve has a very distinct maximum—hence the current effect is by far greatest when both circuits have the same fre-

* \mathcal{E}_{a_0} = Amplitude of the *EMF* acting upon the secondary circuit = $\omega L s_2 \cdot I_1$

quency. The abscissa at the peak of the resonance curve is often called the "point of resonance."

b. The value of the ordinate at the peak, *i.e.*, the size which the current effect in the secondary circuit reaches, at resonance, depends upon the decrements of the primary and secondary circuits, other things being equal (similarly to the maximum amplitude [Art. 56c]). The current effect at resonance is given by:

$$I_{r\,eff}^2 = \zeta \frac{\mathcal{E}_{a_0}^2}{16N_1^3L_2^2} \cdot \frac{1}{d_1d_2(d_1 + d_2)}$$

and if the primary oscillations are undamped:

$$I_{r\,eff}^2 = \frac{\mathcal{E}_{a_0}^2}{8N_1^2L_2^2} \cdot \frac{1}{d_2^2}$$

In Fig. 139 curve *a* (as in Fig. 122) corresponds to decrements $d_1 = 0.08$, $d_2 = 0.02$, curve *b* (as in Fig. 123) to $d_1 = 0.08$, $d_2 = 0.2$. It should be noted that the current effect at resonance is much greater for the first than for the second case.

c. *The Sharpness (Radius of Curvature) of the Peak of the Resonance Curve is of Importance.*—Two curves may be compared in this respect—after adjusting the ordinate scale of one curve—by superimposing the two maximum points, assuming that the point of resonance occurs at the same frequency for both curves. If this is not the case, instead of plotting the frequency, N_2 , of the varied circuit, its ratio to the frequency N_1 of the unchanged circuit is plotted, *i.e.*, N_2/N_1 and instead of the current effect I_{eff}^2 , the values of its ratio to the current effect at resonance, $\frac{I_{eff}^2}{I_{r\,eff}^2}$, are plotted as ordinates.

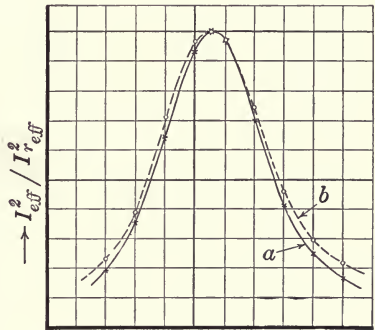

FIG. 140.

Then we may state the following: The peak of the resonance curve will be flatter—the resonance will be less sharp*—according as,

1. The sum of the primary and secondary decrements, $d_1 + d_2$, is greater.
2. The coupling of the two circuits is closer.

In Fig. 139, in which the values of N_2/N_1 are plotted as abscissæ,

* As a *measure* of the sharpness of resonance, the reciprocal value of the dissonance [see Art. 74] at which the current effect is just one-half that obtained at resonance may be used. For the sharpness of resonance, ρ , thus defined, Art. 74 gives the value $2\pi(d_1 + d_2)$ in the case of a normal resonance curve; this value is given in Table XII for different values of $d_1 + d_2$.

the curve b ($d_1 + d_2 = 0.28$) has been redrawn as the curve c by a change of scale. Its peak at resonance is much flatter than that of the curve a , which corresponds to the same coupling but has a lower sum of the decrements, $d_1 + d_2 = 0.1$. On the other hand, the resonance curves a and b of Fig. 140 represent the same decrements with different couplings. The curve b , which corresponds to the closer coupling, is somewhat flatter than a .

d . What has been stated in regard to the resonance curves also holds, at least qualitatively, if curves are plotted with the voltage effects or the maximum amplitudes* as ordinates. Moreover, in all practical cases, these curves have their maximum when the two frequencies are equal to each other.

71. Measurement of the Frequency.—*a. Principle of the Method* (O. LODGE, H. HERTZ). A condenser circuit with a known variable frequency, *i.e.*, a so-called “**measuring circuit**” is used. The oscillator whose frequency is to be determined is caused to act upon this measuring circuit, using as loose a coupling as possible, and the current indicated by a measuring instrument connected in circuit is noted at different frequencies. *That frequency at which the current effect is a maximum is the desired natural frequency of the oscillator.*¹⁰²

Just how the oscillations are produced is immaterial. If the oscillator contains a spark gap, it is simplest to use an induction coil, a transformer or an influence machine. If it contains no spark gap, and a gap is objectionable, its oscillations may be induced by means of either a quenched gap circuit or by impulse excitation [Art. 78c and d , Art. 109]. Under certain conditions it may even be more convenient to use the measuring circuit as the primary, instead of as the secondary circuit, by producing oscillations in it, allowing it to act inductively upon the oscillator through a coupling as loose as possible and varying the frequency in the measuring circuit. The measuring instrument in this case is placed in the oscillator, whose natural frequency is that giving the maximum reading on the instrument.

b . For a laboratory measuring circuit only *air or oil condensers* should be used. Air condensers of variable capacity, *e.g.*, those described in Art. 40 are the best.† Very good results are obtained by connecting two such condensers in parallel, one having large capacity for the rough adjustments to resonance, the other having small capacity for the fine adjustments and determination of the points in the resonance curve near the peak.

The circuit should consist of closely wound coils having only *one*

* These may be measured by the gap length they will jump across, though to be sure not as accurately by far as current or voltage effects.

† A condenser of fixed capacity in conjunction with a coil of variable self-induction (variometer [Art. 38c]) is less desirable.

layer of turns and only one diameter, which must not be small as compared to the length of the coil; the conductor is best made of bands of very thin copper strip or braids of individually insulated very fine (e.g., 0.07 mm.) copper wires.

By the use of several interchangeable coils the frequency may be varied in larger steps, while continuous adjustment is obtained by turning the plate condenser's movable element.

c. *The Measuring Instrument in the Measuring Circuit.*—Other things being equal, the accuracy of a frequency determination increases with the sharpness of the resonance curve. This sharpness is greatest when

1. The damping of the measuring circuit is lowest and
 2. The coupling permitted by the measuring instrument is loosest.
- For both these reasons a highly sensitive instrument is best for this

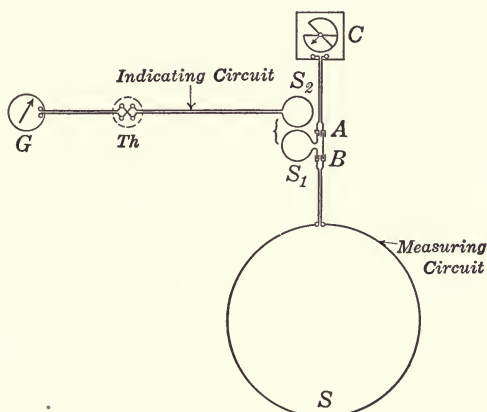

FIG. 141.

purpose, in that it requires very little energy per second to give a sufficient deflection. Hence a bolometer and a thermal element (in conjunction with a mirror galvanometer or a sensitive needle galvanometer) or a thermal galvanometer are preferable to the ordinary hot-wire meters or hot-wire-air thermometers, if great accuracy is required in the determinations. If the oscillations have *very* low amplitude [Art. 78d], it is advisable to replace these measuring instruments by a suitable detector [Art. 51] in conjunction with a telephone or a sensitive galvanometer.

d. The requirement of minimum damping usually forbids the direct connection of these instruments, which customarily have a high resistance, into the measuring circuit. Better results are obtained by causing the measuring circuit to act inductively, through as loose a coupling as possible, upon a closed circuit, the "indicating circuit," which contains the measuring instrument (Fig. 141).

It is advisable to make the distance between the coupling coils S_1 and S_2 (Fig. 141) variable, so that the coupling between the measuring and indicating circuits may be adjusted at will. Furthermore the inductive coupling between these two circuits may be replaced by a direct connection—for instance the measuring instrument is shunted across a few turns in a coil placed in the measuring circuit.

If the arrangement is to serve for all kinds of measurements,* then the inductance of the indicating circuit must be made large as compared to its resistance [Art. 55*b*].

e. In many cases, instead of an indicating circuit with measuring instrument, a well-known demonstration device, a GEISSLER tube† parallel to the condenser in the measuring circuit, will serve the purpose.

At that frequency at which the tube lights, resonance exists between the oscillator, whose frequency is being measured, and the measuring circuit. If the coupling is chosen sufficiently loose so that the tube just begins to light at resonance the determination can be made about as accurately as with a commercial hot-wire meter or hot-wire-air thermometer.

72. Calibration of the Measuring Circuit.—Before determining unknown frequencies with a measuring circuit the latter must first be calibrated, *i.e.*, its own frequency determined for each position of the variable condenser and for the different coils substituted.¹⁰⁵ The principle involved is as follows:

a. First the condenser is calibrated. Any method for measuring capacity can be used for this purpose.‡ The capacity is measured for several different positions of the pointer, and the values found arranged in tabular form or plotted as a curve, so that the value at any position of the pointer may be found by interpolation. For rotating plate condensers as usually constructed the capacity is approximately

$$C = C_0 + a\varphi = a(\varphi + \varphi_0)$$

in which C_0 , a and φ_0 are constants, while φ is the scale deflection of the pointer at any position. The calibration curve is therefore approximately a straight line.

b. The next step is to determine the frequency (wave-length) of the measuring circuit for *one* definite capacity, *i.e.*, one definite position of the pointer of the condenser.

* *e.g.*, measurements such as are discussed in Art. 87, *et seq.*

† The *helium or neon* tubes made according to E. DORN¹⁰³ for the observation of electric oscillations are well adapted for this purpose. Instead of Geissler tubes, a micrometer gap, particularly as made with two fine graphite electrode points is also serviceable.

‡ Convenient methods¹⁰⁴ are: 1. Determination with bridge and telephone, if a known capacity is available for comparison. 2. Absolute determination with tuning fork commutator or rotating commutator.

If the frequency, N (or wave-length, λ) is known for any one position of the condenser, *i.e.*, any capacity, C , then the frequency, N_1 , for any other capacity, C_1 , follows from

$$N_1 = N \sqrt{\frac{C}{C_1}}; \quad \lambda_1 = \lambda \sqrt{\frac{C_1}{C}}$$

The frequencies (or wave-lengths) are then calculated for a number of different condenser positions and a curve is plotted for each test coil, using the condenser scale readings as abscissæ and the calculated frequencies (or wave-lengths) as ordinates. The frequency or wave-length corresponding to any condenser position can then be read from these curves.*

c. The frequency of the measuring circuit for a given capacity can at times be found by *calculating* the coefficient of self-induction of the test coil.

If the test circuit consists of a coil of *one* layer of turns, the number of turns being quite large and if the connection to the condenser is as short as possible, then the self-induction of the leads to the condenser and of the flow of current in the condenser itself becomes negligible as compared to the self-induction of the coil. The latter can be calculated for direct current from well-known formulæ (Table VI) or can be determined experimentally. The coefficient of self-induction for rapid oscillations is very little different from that for direct current, if, by the use of well braided conductors of very fine individually insulated wires, the distribution of the high frequency alternating currents is kept practically the same as with direct current [Art. 39]†. This avoids variation of the coefficient of self-induction with varying frequency.

Otherwise the frequency of the measuring circuit may be *determined experimentally*. In order to apply the methods which follow, a spark gap (electrodes of magnesium, gap length at least several millimeters [Art. 5c]) may be inserted and the measuring circuit fed by an induction coil or similar source of supply (Method 1) or its natural oscillations may be induced through the use of a quenched spark-gap circuit (Methods 2 and 3). Instead of this, it is often more convenient to arrange an auxiliary condenser circuit, measure its frequency (or wave-length) by one of the following methods and then bring the measuring circuit into resonance with the auxiliary condenser circuit.

* It should not be forgotten that the indicating circuit may influence the frequency [Art. 55c]. Hence, either the coupling between S_1 and S_2 (Fig. 141) must be made extremely loose [Art. 78g] or, if this does not give a sufficient deflection to the instrument in the indicating circuit, the calibration should be carried out with the same coupling at which the measuring circuit will later be used.

† The capacity of the coil [Art. 73b] must be taken into consideration in case the condenser has relatively small capacity.

We have, then, the following methods for *determining the frequency*:

1. *For condenser circuits with spark gap: photographing the spark in a rotating mirror* [Art. 2].

2. *Stationary Waves on Lecher's Wires.*—This arrangement (shown in Fig. 142) is as follows: Two parallel wires—whose distance apart is very short compared to their length—are bridged by a fixed cross strip, *AB*. A second cross strip, *CD*, is movable along the wires, as is also a sensitive Geissler tube, *G*.

The condenser circuit, *I*, whose frequency is to be determined, is caused to act inductively upon this system of parallel wires through a very loose coupling. The bridge, *CD*, and the Geissler tube, *G*, are then moved, always keeping *G* midway between *AB* and *CD*, until the tube shows the maximum illumination, indicating that the circuit *ABCD* is in resonance with the condenser circuit. The curves of current and

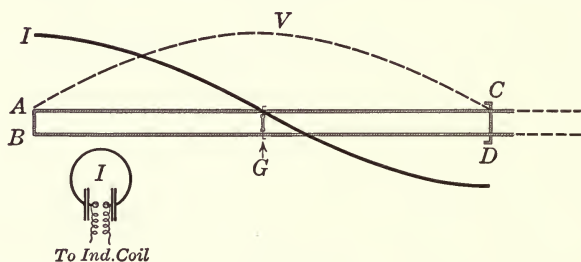

FIG. 142.

potential distribution along the wires will then be as shown by *I* and *V* in Fig. 142* and the distance $AD = BC$ will be a half wave-length.†

If the distance between the wires is chosen sufficiently large to make the inductance considerably greater than the effective resistance, then the velocity, V_L , of electromagnetic waves, advancing along the double wires is approximately ¹⁰⁶):

$$V_L = \sqrt{\frac{1}{LC}} \cdot \left[1 - \frac{1}{8} \left(\frac{R}{\omega L} \right)^2 \right] = \text{approx. } 3 \times 10^{10} \left[1 - \frac{1}{8} \left(\frac{R}{\omega L} \right)^2 \right] \text{ cm./sec.}$$

(*L*, *C* and *R* are the coefficient of self-induction, the capacity and the resistance, respectively, per unit length. From the velocity, V_L , and the wave-length, $\lambda = 2AC = 2BD$, the frequency of the auxiliary circuit follows directly [Art. 19].)

3. *Combination of Calculation and Experimental Methods.*—The main portion of the measuring circuit is arranged in the form of a rectangle

* The arrangement may be considered as a combination of two lineal oscillators [Art. 20].

† On the assumption that the fundamental oscillation (and not a partial wave) is being observed. In case of doubt, it is only necessary to move the tube, *G*, back and forth along the wires to determine this.

ABD_1E_1 ,* one of whose sides is a movable cross strip, D_1E_1 (Fig. 143). Upon this rectangle, the auxiliary condenser circuit (I , Fig. 143) is caused to act inductively and the condenser, C , is adjusted so as to bring the measuring circuit in resonance with the auxiliary condenser circuit;† let C_1 be the capacity required for resonance. Then D_1E_1 is displaced to, say, the position D_2E_2 , and C is again adjusted for resonance. Assume the capacity needed for resonance in this case to be C_2 . As the frequency was the same in both cases, namely, that of the auxiliary circuit, we have

$$\begin{aligned} L_1C_1 &= L_2C_2 \\ \frac{L_1}{L_2} &= \frac{C_2}{C_1} \end{aligned} \tag{1}$$

in which L_1 is the coefficient of self-induction of the measuring circuit, ABD_1E_1 , while L_2 is that of the circuit, ABD_2E_2 .

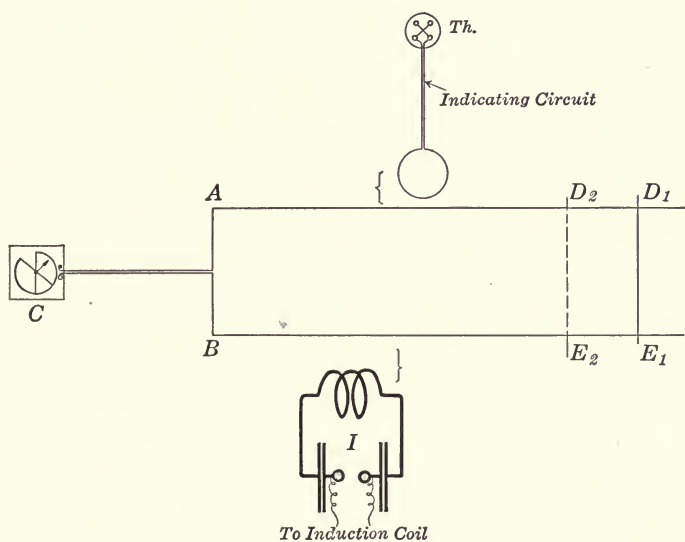

FIG. 143.

Moreover we may write with almost entire accuracy

$$L_1 - L_2 = L^{[1]} - L^{[2]} \tag{2}$$

in which $L^{[1]}$ and $L^{[2]}$ represent the coefficients of self-induction of the rectangles ABD_1E_1 and ABD_2E_2 respectively. $L^{[1]}$ and $L^{[2]}$ may be calculated

* The self-induction of this rectangle [Table VI] will be approximately the desired circuit self-inductance.

† Resonance is observed by means of the maximum indication of the measuring instrument (e.g., thermocouple) in the indicating circuit, which latter must be coupled extremely loosely with the measuring circuit.

from the dimensions (Table VI). From $\frac{L_1}{L_2}$ and $L_1 - L_2$, the values of L_1 and L_2 are then obtained, from which the frequency follows.

73. Determination of Capacities and Coefficients of Self- and Mutual Induction by Resonance.*—a. Self-inductance, Capacity and Dielectric Constants.—The resonance method offers a very valuable and, particularly with the arrangement discussed in Arts. 78*d* and 109*d*, very convenient means of determining capacities and self-inductances. Various methods of procedure are possible.

For instance, to measure the *coefficient of self-inductance*, L , of a given circuit (*e.g.*, a coil), its ends are connected to the terminals of an air condenser of known capacity, C , thus forming a condenser circuit. The natural frequency, N , of this circuit is then determined by resonance.

$$L \text{ then follows from } N = \frac{1}{2\pi\sqrt{LC}}.$$

If it is only a question of comparing the self-inductance, L_1 , of a coil with that, L_2 , of another (which, *e.g.*, might be a known standard of self-inductance) then the two coils are in turn connected to a calibrated adjustable condenser through leads as short as possible and having no appreciable self-inductance or capacity; the circuit so formed is then brought into resonance with *the same* auxiliary circuit by adjusting the condenser in each case. If C_1 and C_2 represent the two capacities, then we have

$$N = \frac{1}{2\pi\sqrt{L_1C_1}} = \frac{1}{2\pi\sqrt{L_2C_2}}, \text{ whence}$$

$$\frac{L_1}{L_2} = \frac{C_2}{C_1}$$

The *capacity* of a condenser would be obtained as follows. Its terminals are connected to a condenser circuit, through suitable leads having no appreciable capacity and a primary circuit is brought into resonance with this. Then the condenser is replaced by a variable calibrated air condenser which is adjusted until resonance is again obtained. This value of the variable air condenser is then the desired capacity of the unknown condenser.

In this way, the *dielectric constant* of a fluid, *e.g.*, an oil, may also be determined. The capacity, C , of a suitable condenser, say of the form illustrated in Fig. 79, is measured with the condenser plates submerged in the oil and then with air as the dielectric, giving a capacity C_0 . Then C/C_0 is the dielectric constant of the particular oil. Only a slight modification of this procedure is necessary to adapt it to the measurement of the dielectric constants of solid materials when used in plate or disc form.

The *main advantage of this resonance method*, which may be widely

* For a more accurate method see Art. 81.

varied for adaptation to the particular conditions of each individual case, lies in the fact that the self-inductance, capacity and dielectric constant can be measured at the *same frequency* at which they will later be used.

b. Capacity of Coils.—Just as the electric field between the coatings of a condenser results in a “capacity,” so the electric field existing between the various turns of a coil, having different potentials, must give the coil a capacity. This much capacity will therefore be added to that of the condenser circuit in which the coil is connected.

Its determination may be carried out as follows (A. MEISSNER²³): The coil is connected to an adjustable condenser whose capacity must be great as compared to that of the coil, and the condenser circuit so formed is brought into resonance with an auxiliary circuit. Then the coil is submerged entirely in a fluid whose dielectric constant, k , is known, surrounding the coil with the fluid to as great a distance in all directions as possible.* Then the variable capacity is reduced by an amount, C' , to again have resonance. It follows that the effective capacity of the coil in air is $\frac{C'}{k - 1}$.

This measurement must under all circumstances be made at the same frequency at which the coil will later be used, as the capacity of a coil depends largely upon the frequency of the alternating current passing through it.

c. The coefficient of mutual induction of two coils, S_1 and S_2 (Fig. 144) may also be found by resonance. The two coils are placed in the relative position in which their mutual induction is to be determined, connected in series (full-line connection in Fig. 144) and the coefficient of self-induction, L_1 , of the two coils thus joined is measured. Then one coil is reversed (dotted lines in Fig. 144) and the total coefficient of self-induction, L_2 , determined for this condition. Then the coefficient of mutual induction is

$$L_{12} = \frac{L_1 - L_2}{4}$$

74. Determination of the Sum of the Decrements of the Primary and Secondary Circuits (V. BJERKNES⁸⁴).—*a.* In order to determine the decrement of an exponentially decreasing oscillation, the oscillator is caused to act inductively upon a measuring circuit with variable frequency and through a very loose coupling so as to obtain the resonance curve [Art. 70]. From the latter the *sum of the decrements*— d_1 of the

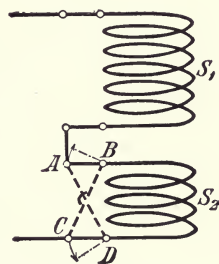

FIG. 144.

* Say, by suspending the coil in the middle of a glass container or jar which is large compared to the coil.

oscillator and d_2 of the measuring circuit is obtained (BJERKNES'S Resonance Method).

How the sum $d_1 + d_2$ is obtained from the resonance curve, depends upon what the ordinates and abscissæ of the curve represent.

1. If the measuring circuit contains a variable condenser, the values of its *capacity*, C , will usually be plotted as abscissæ, while the ordinates would be the current effect I_{eff}^2 (Fig. 145) or the deflection, α^* of a measuring instrument in the indicating circuit. Then we have†

$$d_1 + d_2 = \pi \cdot \frac{(C_r - C)}{C} \cdot \sqrt{\frac{1}{\left(\frac{I_{r\ eff}}{I_{eff}}\right)^2 - 1}} = \pi \frac{(C_r - C)}{C} \cdot \sqrt{\frac{1}{\frac{\alpha_r}{\alpha} - 1}}^*$$

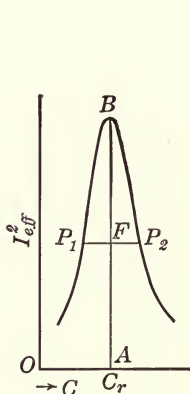

FIG. 145.

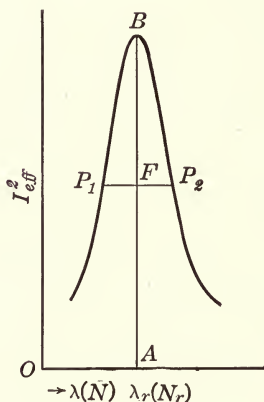

FIG. 146.

in which I_{eff}^2 and α represent current effect and deflection, respectively, when C is the capacity in the measuring circuit, while $I_{r\ eff}^2$, and α_r and C_r represent current effect, deflection and capacity at resonance.

2. If the measuring circuit is calibrated in *frequencies*, these will be used as abscissæ with the current effects or instrument deflections as ordinates. Then we have:

$$\begin{aligned} d_1 + d_2 &= 2\pi \cdot \frac{N_r - N}{N_r} \cdot \sqrt{\frac{1}{\left(\frac{I_{r\ eff}}{I_{eff}}\right)^2 - 1}} = 2\pi \cdot \frac{N_r - N}{N_r} \sqrt{\frac{1}{\frac{\alpha_r}{\alpha} - 1}}^* \\ &= 2\pi \cdot \frac{\overline{P_1 F}}{\overline{O A}} \cdot \sqrt{\frac{\overline{F A}}{\overline{F B}}} \text{ (Fig. 146)} = \pi \frac{\overline{P_1 P_2}}{\overline{O A}} \sqrt{\frac{\overline{F A}}{\overline{F B}}} \end{aligned}$$

* On condition that the deflection is proportional to the current effect. For the exact calibration see, e.g., B. S. LÖWE.¹¹⁴

† The following holds only for points whose abscissa is less than that of the point of resonance (points to the left of the resonance point in Fig. 145). For points to the right of the resonance point, a minus sign should be placed before each expression.

If the measuring circuit is calibrated in *wave-lengths*, λ , and these are used as abscissæ (ordinates again $\propto I_{eff}^2$) then:

$$d_1 + d_2 = 2\pi \frac{\lambda_r - \lambda}{\lambda} \sqrt{\frac{1}{\left(\frac{I_{r\ eff}}{I_{eff}}\right)^2 - 1}}$$

3. In *comparing different resonance curves* it is advisable to proceed as described in Art. 70c. Having found the frequency, N_r , or wave-length, λ_r , and the current effect $I_{r\ eff}^2$ at resonance between the measuring

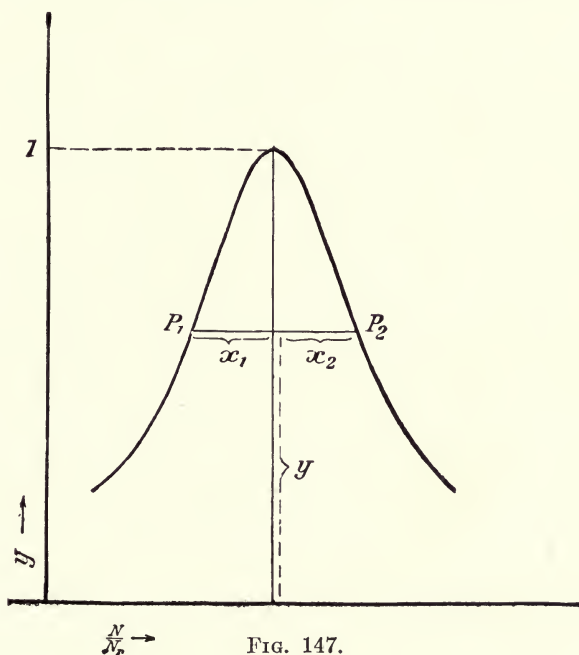

FIG. 147.

circuit and oscillator, the ratio $\frac{N}{N_r}$ or $\frac{\lambda_r}{\lambda}$ is plotted as abscissa and the ratio $\frac{I_{eff}^2}{I_{r\ eff}^2}$ as ordinate, the current effect I_{eff}^2 corresponding to the frequency N and wave-length λ of the measuring circuit. Then the abscissa and ordinate of the resonance point are taken as unity ($x = 1, y = 1$) and we have* (Fig. 147):

* From Art. 70 equation (1) we obtain:

$$y = \frac{I_{eff}^2}{I_{r\ eff}^2} = \frac{\left(\frac{d_1 + d_2}{2\pi}\right)^2}{\left(1 - \frac{N}{N_r}\right)^2 + \left(\frac{d_1 + d_2}{2\pi}\right)^2} = \frac{1}{1 + \frac{x^2}{\left(\frac{d_1 + d_2}{2\pi}\right)^2}}$$

if $x = 1 - \frac{N}{N_r}$.

$$d_1 + d_2 = 2\pi x_1 \sqrt{\frac{y}{1-y}} = 2\pi x_2 \sqrt{\frac{y}{1-y}} = 2\pi x \sqrt{\frac{y}{1-y}} = xA$$

x being the mean of x_1 and x_2 * (Fig. 147).

The quantity $x = \frac{N_r - N}{N} = \frac{N_1 - N_2}{N_1}$ (or x_1 and x_2) is called the "dissonance" of the two circuits. The value of the factor A is given in Table XI for a wide range of ordinates.¹⁰⁷

b. A *simplified* method, much used in practice and usually of sufficient accuracy, is the following (H. BRANDES¹⁰⁸). The instrument in the measuring circuit (or in the very loosely coupled indicating circuit) gives a certain deflection at resonance (capacity C_r). The capacity is then varied in both directions until the deflection of the instrument is just half what it was at resonance. Let C_1 and C_2 be the capacities required for this. Then, from par. (1), we have approximately:

$$d_1 + d_2 = \frac{\pi}{2} \cdot \frac{C_1 - C_2}{C_r} = 1.57 \cdot \frac{C_1 - C_2}{C_r}$$

If φ_1 , φ_2 and φ_r represent the angles of the scale readings of the variable condenser, corresponding respectively to the capacities C_1 , C_2 and C_r , we may write the approximate relation, from Art. 72a as follows:

$$d_1 + d_2 = 1.57 \frac{\varphi_1 - \varphi_2^\dagger}{\varphi_r + \varphi_0}$$

c. The relations given in *a* and *b* also hold if the frequency is varied in the primary circuit and the current effect is measured in the secondary. In that case C , N and λ in the equations of *a* and *b* should be understood as the variable quantities of the primary circuit, while I_{eff} represents the current effect in the secondary.

d. If the oscillations in the primary circuit are *undamped* the equations of *a* and *b* remain correct if we put $d_1 = 0$; the *decrement of the secondary circuit* is then given directly.

75. Abnormal Forms of the Resonance Curves.—In applying the expressions given in Art. 74 to different points of an experimentally determined resonance curve it may happen that the value of $d_1 + d_2$ will be different for different points, *i.e.*, the form of the resonance curve is not that assumed in Art. 74.

a. If the value determined at the various points fluctuates up and down irregularly, this is due to inaccurate observations in obtaining the resonance curve (irregular operation of the interrupter or spark gap). All that can be done in such a case is to take the average of the different

* Theoretically x_1 should = x_2 . In practice, however, because of unavoidable inaccuracies in the measurements, x_1 and x_2 will always be slightly different. Hence it is best to take x the mean value of x_1 and x_2 .

† A *zero method* for determining the decrement has been developed on this principle by L. KANN.¹⁰⁹

values found for $d_1 + d_2$; it is preferable, however, to redetermine the resonance curve.

b. If the resonance curve is decidedly* unsymmetrical, as, for instance, curve *b* in Fig. 173, this indicates condenser leakage discharge; the sum of the decrements can then not be found at all from the resonance curve [Art. 86].

c. With condenser circuits having spark gaps, the following condition is often found: the resonance curve is symmetrical, but the values found for $d_1 + d_2$ become systematically lower as we go down from the top of the curve (Fig. 148). An explanation† for this may be that the amplitude curve of the primary circuit is not, even approximately, an exponential curve.¹¹⁰ In that case the decrement does not remain the same during an oscillation [Art. 9c]. If, in this case, as is usually done, the average of the values obtained at different points is taken,‡ then this mean value is that value of $d_1 + d_2$ which would be obtained with a condenser circuit having an exponential decrease of the amplitude and giving the *same resonance sharpness*.

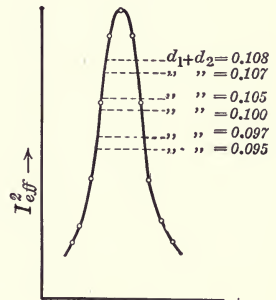

FIG. 148.

This peculiarity is particularly noticeable in condenser circuits having very *short* spark gaps.

With these, the value obtained for d_1 and d_2 at nine-tenths of the height of the peak may be 50 per cent. greater than that obtained at one-third the total height.¹¹¹ This is probably due, at least in part, to the fact that the oscillations are abruptly cut off [Art. 9d]. At any rate, theory has shown (B. МАКРШ¹¹²) that an abrupt cutting off of the oscillations may result in a deformation of this kind in the resonance curve.

d. It may happen that the current effect retains relatively large values for a considerable distance to either side of the resonance point (Fig. 149). This may be due to the fact that the primary either directly or through some other circuit has an inductive effect upon the indicating circuit.

Or the measuring circuit may have been coupled too closely with the primary circuit. The resonance curve will then be of the form shown in Fig. 150; the decrement values from such a curve will vary from point to point and be too high throughout.¹¹³

e. If the resonance curve has two peaks, this may be taken as an

* A slight dissymmetry appears when the factor *A* [Art. 55b] is not constant, depending upon the frequency.

† Furthermore the instrument deflections used as ordinates may not be exactly $\propto I_{eff}^2$.

‡ Usually the value obtained at one-half the total height of the resonance curve is identical with this mean value.

indication that there are two distinct oscillations in the primary circuit [Fig. 175]. Such curve forms, however [e.g., the heavy, full line in Fig. 151] may result in quite another way, namely, if spark or brush discharges pass between the coatings or plates of the variable condensers (or at

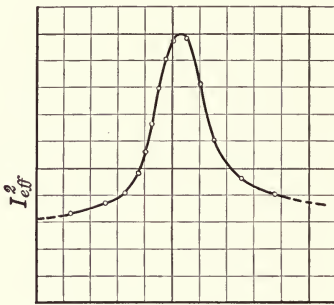

FIG. 149.

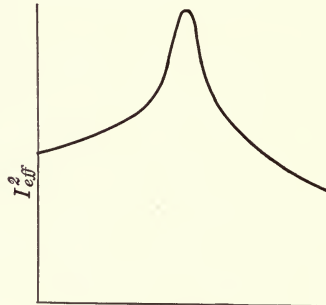

FIG. 150.

other points of the measuring circuit). Thus in Fig. 151 the real resonance curve is shown by the broken line: the actually observed full-line curve having been caused by a reduction of the current effect at the middle portion of the curve due to spark discharges.

76. Determination of the Decrements of the Primary and Secondary Circuits.—a. With a damped primary circuit, the resonance curve gives only the *sum* of the decrements of the primary and secondary circuits. To obtain the individual decrements, we may, for example, proceed as follows (method of V. BJERKNES⁸⁴). A known resistance R' , is connected into the secondary circuit,* which has been brought into resonance with the primary circuit (deflection in the indicating circuit = α_r). This will cause an increase in the secondary decrement d_2 by an amount

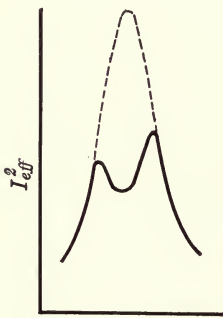

FIG. 151.

$$d' = \pi R' \sqrt{\frac{C_2}{L_2}} \tag{1}$$

But the instrument deflection, d_r , will be reduced to a value α' . Then

$$d_2 = d' \cdot \frac{1}{\frac{\alpha_r}{\alpha'} \left(\frac{1}{1 + \frac{d'}{d}} \right) - 1} \tag{2}$$

in which d is the value of $d_1 + d_2$ obtained from the resonance curve.

* In the measuring circuit of Fig. 141, the terminals AB are provided for this purpose.

† Assuming that the deflections $\propto I_{eff}^2$. Otherwise the current effects must be substituted for the deflections in the equation.

This expression is simplified into

$$d_2 = d' \frac{1}{\frac{\alpha_r}{\alpha'} - 1}$$

when d' is very small compared to d .

Having thus determined d_2 , the decrement, d_1 of the primary circuit, follows from the value of $d_1 + d_2$ obtained from the resonance curve.

b. It has already been shown [Art. 74d] that with *undamped* oscillations in the primary circuit the decrement of the secondary can be obtained directly either from the resonance curve or from the simplified procedure of Art 74b. A still simpler method may be applied under these conditions.* First the secondary circuit is brought into resonance with the primary. Assume that the current effect in the secondary (or in an indicating circuit coupled thereto) = α . Then a known resistance, R' , is connected into the secondary circuit, thereby reducing the current effect to a value α' . Then if R represents the effective resistance of the secondary circuit before R' was introduced, we have

$$R = \frac{R'}{\sqrt{\frac{\alpha}{\alpha'} - 1}} \dagger$$

Then the decrement follows from R and Art. 8d.

c. These methods of course offer a means for *calibrating the measuring circuit with respect to the decrement*. The values of d_2 are found for the various current paths and different condenser values and are then listed in tabular form or plotted as a curve.

In this connection it should be remembered that the decrement d_2 of the measuring circuit will be affected by the indicating circuit unless the coupling between them is extremely loose.

A sharp indication as to whether or not this condition exists is given by the following. A coil S'_1 of the same dimensions as S_1 is connected between A and B in the measuring circuit of Fig. 141 and is caused to act inductively upon another coil S'_2 having the same dimensions as S_2 . The distance between S'_1 and S'_2 is chosen the same as that between S_1 and S_2 . A circuit of the same dimensions and resistance as the indicating circuit is then constructed and joined to S'_2 . If this causes no change in the deflection of the instrument in the indicating circuit at resonance,

* For the development of this method as applied to damped oscillations (see S. LÖWE¹¹⁴).

† If the measuring instrument used gives the effective value of the current, I_{eff} and I'_{eff} respectively, then $R = \frac{R'}{\frac{I_{eff}}{I'_{eff}} - 1}$.

then the indicating circuit has no effect upon the decrement of the measuring circuit.

This condition can not be obtained when using hot-wire thermometers or commercial hot-wire meters, with which the decrement is largely dependent upon the indicating circuit and its degree of coupling to the measuring circuit. The values of d_2 obtained in calibration therefore hold only for those coils S_1 and S_2 used in calibrating and only for the particular position of those coils used during calibration.

77. Measurement of Small Changes in the Decrement.—The method—*change in the current effect at resonance*—given in Art. 76, may also be used to advantage where small changes in the decrement (*e.g.*, as caused by eddy currents) are in question.

a. Equation (2), Art. 76, when d_2 is known, *i.e.*, with calibrated measuring circuit, may be used to determine any change d' in the decrement, whether in the primary or in the secondary circuit. This gives the decrement change with much greater accuracy than by obtaining it from the resonance curve.*

b. Sometimes, particularly for comparisons, it is very convenient to use the “**equivalent resistance**,” instead of the change in the decrement, d' , produced by some such cause as *e.g.*, eddy currents. The equivalent resistance is that resistance, R' , which would have to be connected into the circuit to increase the decrement by d' .

This equivalent resistance, R' , can be calculated from equation (1), Art. 76, *i.e.*, from the measured increase of the decrement, d' , and the dimensions of the circuit.¹¹⁴

If *only* R' is desired, it is much simpler to apply the method given above as a *compensation method*. For instance, assume a conductor brought near the secondary circuit has caused a reduction of the deflection in the indicating circuit from α to α' . To determine its equivalent resistance, the conductor is removed and resistance inserted in the secondary circuit until the deflection at resonance again falls from α , to α' .† The resistance having this effect is R' .

78. Measurements with Resonance Circuits in General.—a. For the *excitation or production of the oscillations* in the primary circuit, four methods are available in the laboratory, *viz.*:

1. Undamped oscillations by the arc method.
2. Excitation by a quenched spark-gap circuit (Fig. 152).
3. Impulse excitation [d].

* Other things being equal, the accuracy of the determination increases as the sum of the decrements of the primary and secondary decreases; hence it is advisable to use a quenched spark-gap circuit for producing the oscillations [Art. 78c].

† The frequency may be influenced by the eddy currents in which case it must be brought back to its original value by suitable regulation.

4. Charging the condenser in the primary circuit and discharging through a spark gap.

The *requisite condition* underlying the equations of Arts. 70, 74 and 76 are:

1. The primary oscillation must be of constant frequency.
2. The amplitude curve must be either a straight line parallel to the axis of abscissæ (undamped oscillations) or an exponential curve.

None of the methods of excitation given above strictly fulfills both requirements. The form of the resonance curve gives some indication of how nearly they are fulfilled [Art. 75]. Hence even when the measurements do not absolutely necessitate it, it is advisable to plot the resonance curve.

To these requirements should be added another, of great practical importance, viz., *constant amplitude and frequency of discharge*. If these are not constant, the fluctuations of the instruments will prevent accurate measurements [also see *g*].

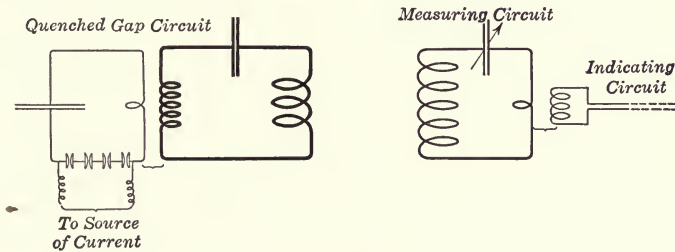

FIG. 152.

b. The presence of upper harmonic oscillations of higher frequency in addition to the fundamental, when using the *arc method for undamped oscillations* (Chap. IX¹¹⁵) does not generally interfere if the secondary is a condenser circuit.* But if the frequency of the fundamental oscillation is not entirely constant, its fluctuations will cause a widening of the resonance curve and application of the equations of Art. 74 will give too high a value for the decrement. The errors, however, which occur in this way with arcs especially intended for measurements [Art. 125], once skill is attained in their manipulation, are not large. But, what is most unsatisfactory, is not so much the average amount of the error as the uncertainty of its extent at any particular instant. Another disadvantage of the arc method is the difficulty of keeping the amplitude sufficiently constant.

Otherwise, measurements, particularly of the decrement, are especially convenient and simple with undamped oscillations.

* With an open secondary circuit (antenna) this may cause disturbance if an upper harmonic of the secondary should happen to be in resonance with an upper harmonic of the primary circuit.

c. If the primary oscillations are induced by means of a *quenched spark-gap circuit*, then from the moment the oscillations in the gap circuit stop, those in the primary circuit fulfill the requirements given above, viz., the frequency is absolutely constant, the amplitude curve is an exponential curve.* Hence the resonance curves obtained by this method have the normal form as shown in Art. 74.

Excitation by means of a quenched gap circuit, moreover, has the great advantage that the oscillations in the primary circuit are much less damped than they would be if the primary circuit included a spark gap. In addition, a very high number of discharges per second may be used. This increases the current effect to such an extent that the coupling between the primary and the measuring circuit and also between the latter and the indicating circuit, if one is used, may be made very loose.

The regularity of the oscillations depends upon the kind of gap used. The mercury arc lamp and especially series gaps in hydrogen are well adapted for the purpose. Also the series spark gap of TELEFUNKEN with disc-shaped silver electrodes in air [Art. 111c], as well as PEUCKERT'S generator [Art. 111e] can be used to advantage.¹¹⁶ They are suitably operated by an alternating-current transformer (also an induction coil fed by alternating current), or a resonance coil.

d. The third method *impulse excitation* of the primary circuit [Art. 109d] is experimentally of extreme simplicity: a storage battery of a few cells and a suitable interrupter giving a high number of interruptions per second are all that is needed to produce the oscillations. To determine resonance in the secondary circuit a detector [Art. 51] with telephone or galvanometer is used, the simplest kind of detector, such as, *e.g.*, is quickly made from a piece of galena and a point of graphite pressed lightly against the galena by a spring, suffices entirely. If the primary circuit is properly designed, its oscillations will be only very slightly damped. The high sensitiveness of the detector and the fact that the current effect (even though the oscillations have a small amplitude) is relatively large on account of the high number of discharges per second, permit extremely loose coupling between the primary and secondary circuits. Hence the various measurements based on the resonance principle [Art. 73] can be made with this method just as accurately as with any method using the current effect.

For determinations of the decrement from the resonance curve, this method is suitable only if the detector works with great regularity and is calibrated.

e. The fourth method, namely, charging the condenser in the primary circuit and allowing it to discharge through a *spark gap* [Art. 1], has the

* The presence of two oscillations up to this moment will interfere less as the coupling to the quenched gap circuit is made closer, *i.e.*, the faster the oscillations in the latter die out.¹²¹

advantage that the amplitude can be very easily varied over wide limits; its disadvantage lies in the fact that the amplitude curve of the resultant oscillations does not approximate an exponential curve. Moreover the discontinuing of the oscillations in the primary circuit at a certain instant and the fact that the spark gap affects even the frequency [Art. 9] must be taken into consideration. Entirely aside from the questionable value of determinations of the decrement of the *primary* circuit by this method, it is very doubtful to what extent we may draw conclusions from the resonance curve under these circumstances as to the decrement of the *secondary circuit*.

On the other hand, a great many determinations have shown that this method is entirely accurate for frequency measurements and gives at least approximately correct results for secondary decrements, on condition that such spark gaps as have been found to cause wide variations from the conditions existing in condenser circuits having no spark gap are avoided, *i.e.*, spark gaps less than 5 mm. long and having copper or silver electrodes. Furthermore the following should be considered in regard to the primary circuit. The average value of d_1 , obtained from the resonance curve [Art. 75c], does not correctly characterize the decrease with time of the amplitude in the primary, but defines with sufficient accuracy the shape of the resonance curve and hence the *sharpness of resonance* and the *maximum current effect* attainable with the particular primary circuit in a loosely coupled secondary. But these are just the quantities on account of which the decrement is of practical interest. The decrease in the amplitude itself is only of minor importance in practice.

To obtain the greatest possible *regularity* in the discharges only a low number of sparks per second should be used and partial spark discharges be avoided, assuming the use of metallic spark gaps in air.* *Magnesium* is the best electrode material in air; tin, zinc and aluminium are less suitable; copper and silver are especially bad for the purpose.

The regularity of the sparks is affected by retardation of the discharge [Art. 42b], so that all means for reducing the retardation tend to increase the regularity. Subjecting the gap to ultra-violet light has already been mentioned in Art. 42b as one such means. Another method is to attach a fine point (say a pointed wire) to one electrode (Fig. 153). The position of the point can be so adjusted until the point discharge causes a very regular main discharge without materially changing the potential amplitude (W. EICKHOFF¹¹⁸). If magnesium electrodes are used, however, this method usually need not be applied. An induction coil with D.C. supply

* If a mercury arc lamp¹¹⁷ or a metallic gap in hydrogen is used, many partial spark discharges may be used without resulting in irregularities; in this way the current effect can be greatly increased. However, the much higher damping of such spark gaps is the bad part of the bargain.

and a mercury-turbine interrupter* or a large influence machine, but, best of all by far, a resonance coil with A.C. supply [Art. 114a] serve as suitable current sources.

f. For the *measuring circuit* minimum damping offers the advantage that the frequency, due to the increased sharpness of resonance, as well as the decrement of any primary circuit can both be more accurately determined, other things being equal.

If it is to be expected that the primary oscillations will be of relatively short duration (short spark gaps) then it would seem advisable to make the decrement of the measuring circuit about equal to that of the primary circuit.¹¹²

g. To the requirements of a should be added the very important one: the *coupling between primary and secondary circuits must be extremely loose, i.e.*, so loose that there is no appreciable reaction.

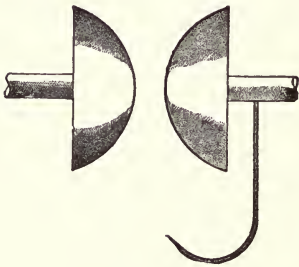

FIG. 153.

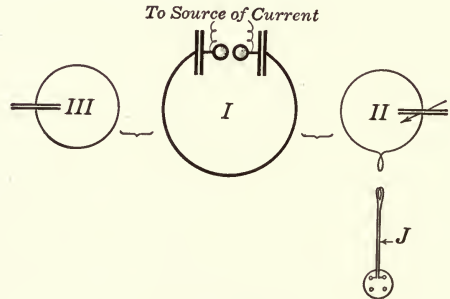

FIG. 154.

Whether or not that is the case, can be determined as follows. Construct a condenser circuit (*III*, Fig. 154) of about the same dimensions as the secondary circuit and coupled to the primary circuit about as closely as the secondary is. If this causes no change in the current effect in the secondary at resonance, it follows that no appreciable reaction exists between the secondary and primary circuits.¹¹⁹

Commercial wave meters have sacrificed the fulfillment of these various requirements in order to make use of the convenient but relatively non-sensitive commercial measuring instruments. Hence the values for $d_1 + d_2$ [Art. 74] and for d_2 [Art. 76] obtained by them are, in general, too large. The error may amount to even 30 per cent.¹²⁰ It can be decreased by increasing the current effect in the primary, as this allows a looser coupling to obtain a sufficient deflection in the indicating circuit.

h. The wires leading to the current source (*e.g.*, transformer) must be connected directly at the terminals of the spark gap (thus in Fig. 2, at

* It is advisable to use a motor of somewhat larger capacity than that generally supplied by the manufacturers and to mount a fly-wheel on its axis.

the points F_1 and F_2 , and not at A and B), as otherwise the damping of the primary circuit may be considerably increased.

i. If a revolving coil, mirror galvanometer is used in the indicating circuit, it is usually advisable to *ground the coil*. Otherwise the coil may become charged and react similarly to the needle of a quadrant electrometer.

79. Commercial "Wave Meters".¹²¹—*a.* Wave meters, which are simply commercial constructions of the measuring circuits described in Art. 71, are arranged for one or more of the following duties:

1. Determination of the natural frequency of any oscillator and through this, of the capacity, the self-inductance, the mutual inductance [Art. 73], and the degree of coupling [Art. 87].

2. Determination of the decrement of any circuit.

3. Production of oscillations of any desired frequency (the wave meter used as primary circuit).

These are all based on the resonance principle described in Arts. 70 and 74. Hence the essential part is a condenser circuit whose frequency can be continuously varied over a known range. For this purpose wave meters have either

1. A condenser of continuously variable capacity and one or more coils of fixed self-inductance (*e.g.*, TELEFUNKEN Co.,¹²² MARCONI Co.¹²³), or

2. One or more condensers of fixed capacity and a coil of variable self-inductance ("variometer") (*e.g.*, G. SEIBT [C. LORENZ¹²⁴], IVES, DE FOREST), or finally

3. Both capacity and self-inductance are variable, in some cases the movable parts of the condenser and the inductive coil being linked so as to move in unison (*e.g.*, J. A. FLEMING'S Kymometer,¹²⁵ PÉRI¹²⁶).

The movable parts are usually provided with a pointer moving over a scale, which mostly permits a direct reading of the wave-length (or frequency) at each position of the pointer.

b. To measure the frequency (or wave-length) of an oscillator, *e.g.*, a condenser circuit, the wave meter is set up near it and the wave meter's frequency varied until it is in resonance with the oscillator. Resonance is indicated either by

1. The lighting of a Geissler tube, or

2. The maximum deflection of a measuring instrument (*e.g.*, hot-wire meter) connected directly into the measuring circuit or coupled to it, or

3. The maximum sound intensity in a telephone which is connected, together with a detector, in parallel to a portion of the measuring circuit or which is in a separate indicating circuit.

Some wave meters have several of these arrangements provided at the same time.

c. The decrement of an oscillator is rarely determined in practice by the resonance curve method of Art. 74a, it being customary to employ the simplified method given in Art. 74b, using the measuring instrument mentioned in b2 [Art. 79]. Both methods give the sum of the decrements of the oscillator and the measuring circuit; the latter either being known or found as per Art. 76, the oscillator decrement follows.

Another method,¹²³ which gives approximate values of the decrement without the use of an actual measuring instrument, only employing a detector and telephone, is that used in the MARCONI "Decremeter." It is based on the equation of Art. 74a2,

$$d_1 + d_2 = 2\pi \frac{N_r - N}{N_r} \sqrt{\frac{1}{\left(\frac{I_{r\ eff}}{I_{e\ ff}}\right)^2 - 1}}$$

The arrangement is shown diagrammatically in Fig. 155. The measuring circuit contains a variable condenser, C , a self-inductance, L , a small coil, L_3 , which can be either connected into the circuit or else short-circuited, and a coil, L_2 , having thirty-two turns of heavy wire. The coefficient of self-inductance of L_3 is so chosen that by the introduction

of this coil the frequency of the measuring circuit is changed by 4 per cent., this change, as shown in Art. 3, being independent of the capacity of the circuit. The detector, D , and the telephone, T , with the cell, E , are shunted across the coil L_2 from its end A to the sliding contact S .

In order to determine the decrement of an oscillator the measuring circuit, without the coil L_3 , is first brought into

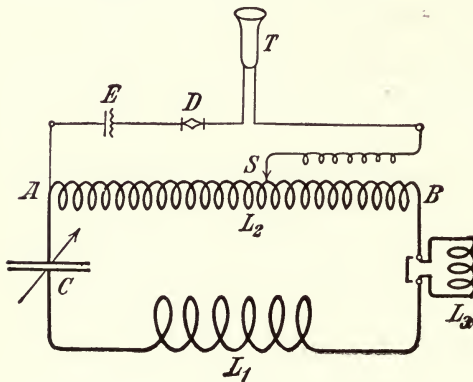

FIG. 155.

resonance with the oscillator (maximum sound intensity in the telephone). Then:

1. The measuring circuit is put out of resonance to the extent of 4 per cent. by inserting L_3 , and the tone in the telephone noted with the sliding contact at B , *i.e.*, with thirty-two turns of L_2 in circuit. Let $I_{e\ ff}^2$ be the current effect in the measuring circuit under these conditions.

2. The coil L_3 is again cut out, bringing the measuring circuit into resonance again. The sliding contact is then displaced until the tone in the telephone is just as loud as it was in 1. Let n be the number of turns now between A and S , and let $I_{r\ e\ ff}^2$ be the current effect in the measuring

circuit. Provision is made by suitable arrangements for quickly obtaining the conditions of 1 and 2.

In the arrangement of Fig. 155, the current amplitude in the detector during each period is proportional to the current amplitude in the measuring circuit and to the number of turns in parallel with the detector. Hence the current effect in the detector must be proportional to the current effect in the measuring circuit and to the square of the number of parallel turns. Therefore, if the detector action depends upon the current effect, and if the tone in the telephone and therefore the current effect in the detector is the same in both cases 1 and 2, then we have

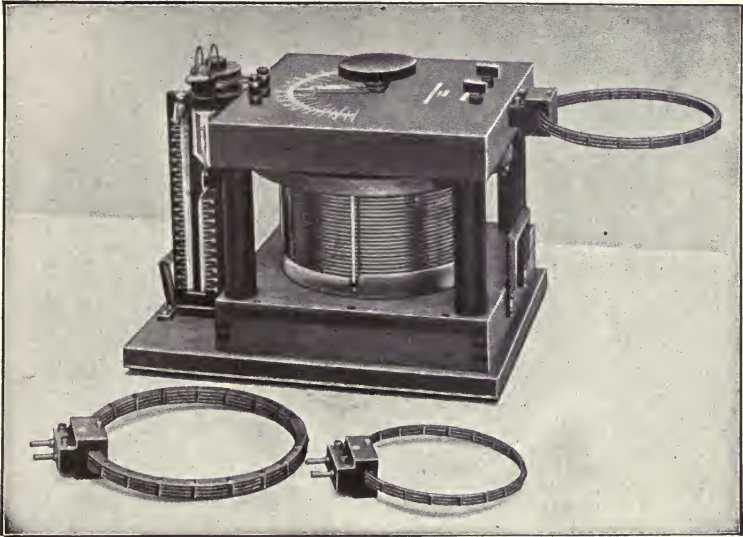

FIG. 156.

$\left(\frac{I_{ref}}{I_{eff}}\right)^2 = \left(\frac{32}{n}\right)^2$. Applying this to Art. 74a2, we obtain the sum of the decrements of the oscillator and the measuring circuit:

$$d_1 + d_2 = 2\pi \times 0.04 \sqrt{\frac{1}{\left(\frac{32}{n}\right)^2 - 1}}$$

d. In order to use a wave meter as a *primary circuit*, either

1. Small spark gaps are inserted in it so that oscillations may be produced by means of an induction coil, or
2. Means are provided for producing oscillations by impulse excitation [Art. 109].

e. Only a few of the many types of commercial wave meters can be described here. Probably that of J. ZENNECK¹²⁷ was the first used in

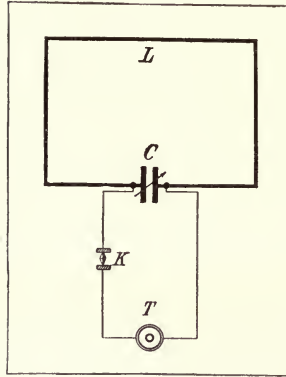

FIG. 157.



FIG. 158.

wireless telegraphy. It consisted of a condenser of fixed capacity and continuously variable self-inductance. A Geissler tube or a spark gap served for frequency measurements by means of resonance, while a bolometer was used for decrement determinations.

The next step in this direction is represented by the FRANKE-DÖNITZ (Telefunken) wave meter shown in Fig. 156; it consisted of a variable condenser, interchangeable coils for the different ranges and a hot-wire-air thermometer. Very similar in design and equally simple is the port-

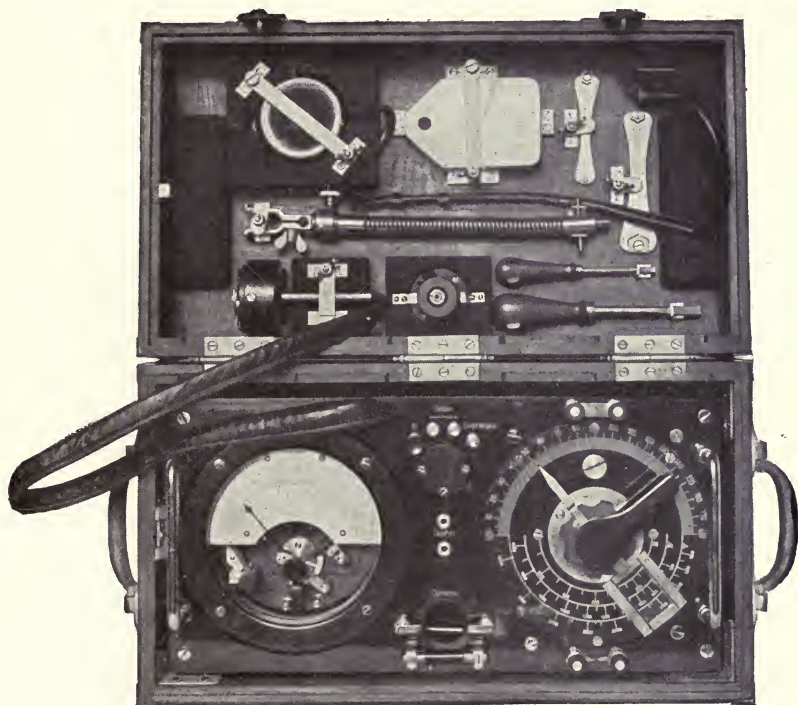

FIG. 159.

able wave meter of the MARCONI Co., of which Fig. 157 shows the connections diagrammatically, Fig. 158 the finished construction; it consists of a variable condenser, a fixed self-inductance of rectangular shape mounted into the cover of the case and a carborundum detector [Art. 160] with telephone.

The later wave meter of the TELEFUNKEN Co. (Fig. 159) whose adjustable condenser, in addition to its graduated scale, also has three scales of wave-lengths corresponding to the different coils, while more complicated, has a much wider range of usefulness. The same applies to the portable decremeter of the MARCONI Co. (Fig. 160).

f. The *direct-reading* wave meter of R. HIRSCH*,¹²⁸ is based upon a very neat application of the resonance principle.

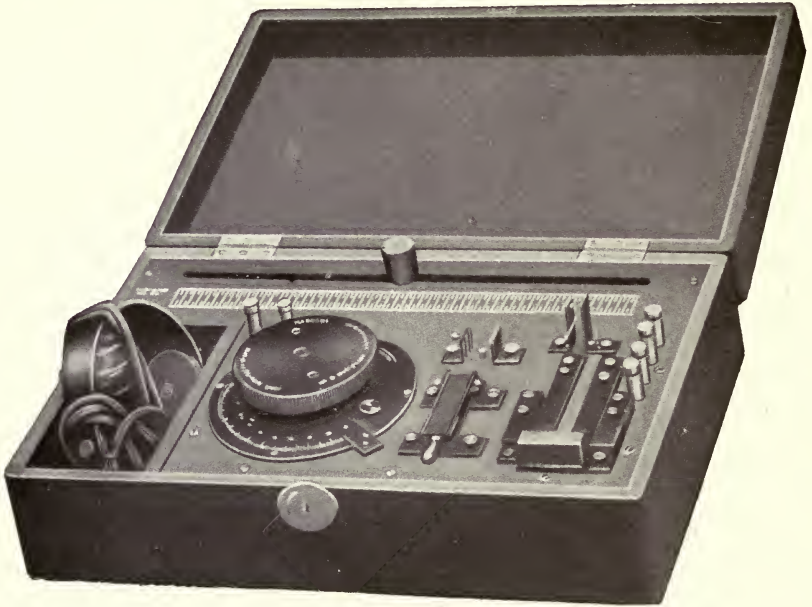

FIG. 160.

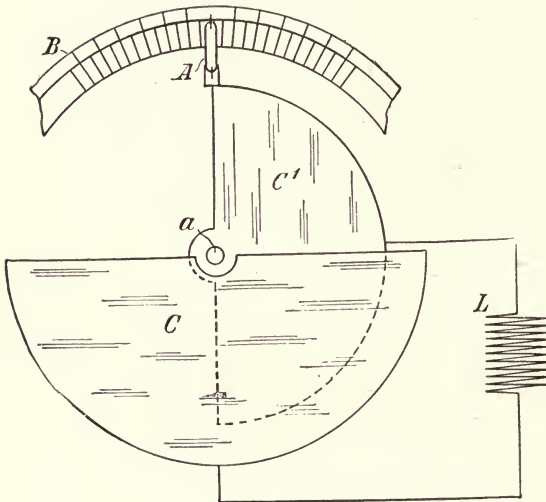

FIG. 161.

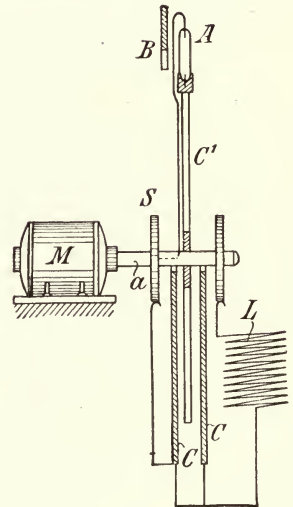

FIG. 162.

* Manufactured by DR. E. HUTH, G. M. B. H., Berlin, to whom the author is indebted for the cuts.



FIG. 163.



FIG. 164.

The measuring circuit (Figs. 161 and 162) consists of a fixed self-inductance, L , and a variable condenser having one fixed, C , and one movable, C^1 , set of plates, the latter being rotated by a motor. This also rotates a small helium tube, A , over a scale, B , the tube being connected in parallel with the condenser. The rotation of the movable element of the condenser causes a continuous variation in the frequency of the measuring circuit. At that position at which the measuring circuit is in resonance with the oscillator under observation, the tube becomes illuminated and a bright line is seen on the scale at the point where the helium tube is at the instant of resonance. By indicating along the scale the wave-lengths of the measuring circuit corresponding to each position of the rotating element, the instrument becomes direct-reading. Two forms of this wave meter are shown in Figs. 163 and 164.

2. RESONANCE CURVE OF THE DYNAMOMETER EFFECT

(L. MANDELSTAM AND N. PAPALEXI¹²⁹)

80. General.—*a.* Assume a movable coil, S_2 , in a vertical plane, *e.g.*, suspended on a vertical wire, placed within a fixed coil, S_1 , also in a vertical plane. If a current I_1 is passed through S_1 and I_2 through S_2 , the

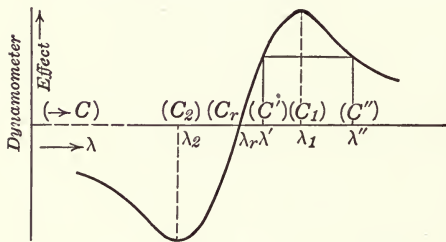

FIG. 165.

turning moment to which the movable coil is subjected $\propto \overline{I_1 I_2}$. If I_1 and I_2 vary rapidly with time, as *e.g.*, in high frequency alternating currents, the coil will in general not respond to the rapid variations and its motion will be determined by the average turning moment, *i.e.*, the average value of $\overline{I_1 I_2}$. This average value

is called the “**dynamometer effect**,” $\overline{I_1 I_2}$ ¹³⁰, from the use of this arrangement of a movable coil in the field of a fixed coil in the well-known dynamometer type of wattmeters. This arrangement also always makes it possible to measure $\overline{I_1 I_2}$.

b. Assume now, as in Art. 70, that a primary circuit of constant frequency (and wave-length) acts inductively upon a secondary circuit of variable wave-length, *e.g.*, an adjustable condenser circuit. Let I_1 and I_2 represent the currents in the primary and secondary circuits respectively. The dynamometer effect of the two currents is measured and a curve plotted in which the abscissæ are the wave-lengths (or capacities) of the variable secondary circuit, the ordinates being the corresponding dynamometer effects.

The resulting curve will be of the form shown in Fig. 165; as may be shown theoretically¹²⁹ this curve passes *through the axis of abscissæ* when

the wave-length of the secondary circuit is equal to that of the primary, *i.e.*, when the two circuits are in resonance.

c. The form of this resonance curve, similarly to the current effect curve [Art. 70c] depends on:

1. The sum of the decrements of the primary and secondary circuits.
2. The degree of coupling between the two circuits.

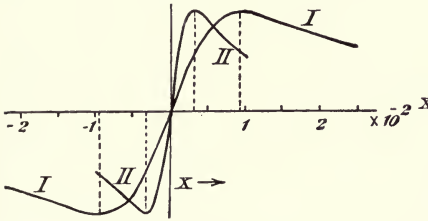

FIG. 166.

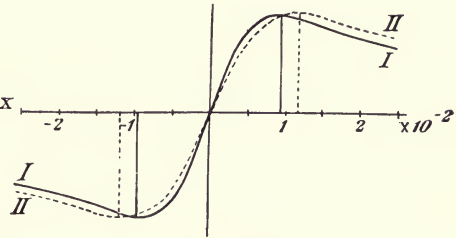

FIG. 167.

The effect of the size of the decrement is shown by curves *I* and *II* of Fig. 166* and the effect of the percentage of coupling is shown by curves *I* and *II* of Fig. 167.† In these curves the abscissæ are the dissonance values,

$$x = \frac{\lambda_2 - \lambda_r}{\lambda_2} = \frac{1}{2} \frac{C_2 - C_r}{C_2}$$

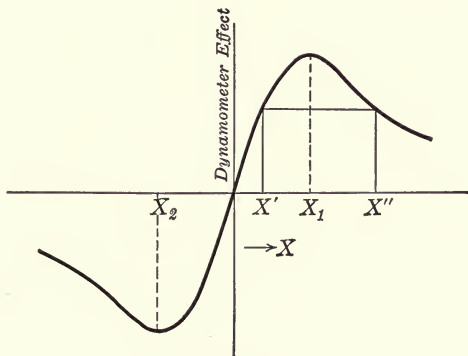

FIG. 168.

d. If the coupling between primary and secondary circuits is extremely loose, we have the following relations (Fig. 168):

1. Let x_1 and x_2 be the dissonance values at which the dynamometer effect has its maximum positive and negative values respectively. Then

$$d_1 + d_2 = 2\pi x_1 = 2\pi x_2 = 2\pi \frac{x_1 + x_2}{2}$$

* *I* : $d_1 = 0.05, d_2 = 0.01$; *II* : $d_1 = d_2 = 0.01$.

† $d_1 = 0.05, d_2 = 0.01$; *I* : coupling extremely loose; *II* : $K' = 0.3$ per cent.

2. If a line is drawn parallel to the axis of abscissæ and intersecting the resonance curve at the points whose abscissæ are x' and x'' , then

$$d_1 + d_2 = 2\pi\sqrt{x'x''}$$

81. Determination of the Frequency (Wave-length).—a. A method for determining the frequency (wave-length) of a primary circuit follows directly from Art. 80b. The primary is caused to act inductively upon a measuring circuit through an extremely loose coupling and the dynamometer effect $\overline{I_1 I_2}$ of the primary current I_1 and the measuring current I_2 is measured. The frequency of the measuring circuit is varied until the dynamometer effect becomes zero. That frequency (wave-length) of the measuring circuit at which this occurs is the desired frequency of the primary circuit.

b. Instead of leading the primary and measuring currents directly through the dynamometer, it is more convenient to have both circuits act

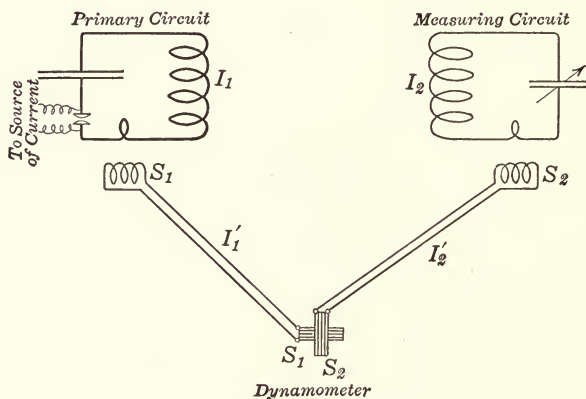

FIG. 169.

inductively, through as loose a coupling as possible, upon two coils, S_1 and S_2 (Fig. 169) which are connected to the dynamometer. It can be shown¹²⁹ that the dynamometer effect $\overline{I'_1 I'_2}$ of the currents induced in these coils follows practically the same changes as $\overline{I_1 I_2}$.

c. Wave-length (or frequency) determination by means of the dynamometer effect has the following advantages over the determination by means of the current effect [Art. 71].

1. It is much more accurate. In the current effect method we work around the peak of the resonance curve and slight variations in the frequency cause but very slight (percentage) changes in the deflection. Hence, in order to obtain the *exact* point of resonance it becomes practically essential to plot the resonance curve or at least its upper part. The dynamometer determination, on the other hand, is a zero method. The slightest deviation from resonance produces a noticeable deflection in

the measuring instrument. The dynamometer method is therefore to be used wherever *small changes in the frequency* (or in the capacity, dielectric constant or coefficient of self-induction [Art. 73]) are to be measured; in accuracy it surpasses by far all other methods.

2. The accuracy of frequency determinations by means of the *current effect* method, depends upon the accuracy with which the resonance curve can be obtained, *i.e.*, upon the regularity of the discharges per second and the amplitude. The dynamometer method is independent of both these factors.

82. Decrement Determination.—This is based upon the relations described in Art. 80*d*. As in the case of the current effect method, the sum of the primary and secondary decrements is obtained. The connections are those shown in Fig. 169, with the stipulation that the coupling between the primary and measuring circuits must be extremely loose.

a. To find the sum of the decrements by Art. 80*d*1, the wave-length, λ (capacity, C) of the measuring circuit is varied until the dynamometer effect is a maximum either on the positive ($\lambda = \lambda_1, C = C_1$) or the negative ($\lambda = \lambda_2, C = C_2$) side. Then, if λ_r and C_r are the respective values of λ and C at resonance, *i.e.*, when the dynamometer effect is zero, we have:

$$\begin{aligned} d_1 + d_2 &= 2\pi \frac{\lambda_1 - \lambda_r}{\lambda_1} = 2\pi \frac{\lambda_r - \lambda_2}{\lambda_2} = \text{approx. } \pi \frac{\lambda_1 - \lambda_2}{\lambda_r} \\ &= \pi \frac{C_1 - C_r}{C_1} = \pi \frac{C_r - C_2}{C_2} = \text{approx. } \frac{\pi}{2} \frac{C_1 - C_2}{C_r} \end{aligned}$$

With this method it is not necessary to determine the entire resonance curve. However, for most purposes the method is sufficiently accurate, as it is relatively easy to sharply locate a maximum and as the absolute value of the deflection at the maximum has no bearing upon the results.

b. If great accuracy is of importance, the method based on Art. 80*d*2 should be employed. The resonance curve is plotted with either the wave-lengths or capacities of the measuring circuit as abscissæ. Then a line is drawn parallel to the axis of abscissæ and intersecting the curve at two points whose abscissæ are λ' and λ'' or C' and C'' respectively. Then if λ_r and C_r are the resonance values, we have:

$$\begin{aligned} d_1 + d_2 &= 2\pi \sqrt{\left(\frac{\lambda' - \lambda_r}{\lambda'}\right) \cdot \left(\frac{\lambda'' - \lambda_r}{\lambda''}\right)} \\ &= \pi \sqrt{\left(\frac{C' - C_r}{C'}\right) \cdot \left(\frac{C'' - C_r}{C''}\right)} \end{aligned}$$

83. The Dynamometer.—Modified forms of the ordinary dynamometers may be used for measuring the dynamometer effect, a fixed and a movable coil, the latter suspended on a bronze strip and provided with a

mirror similarly to the coils of a *Deprez-d'Arsonval* mirror type instrument. Both coils must have only a small number of turns.¹³¹

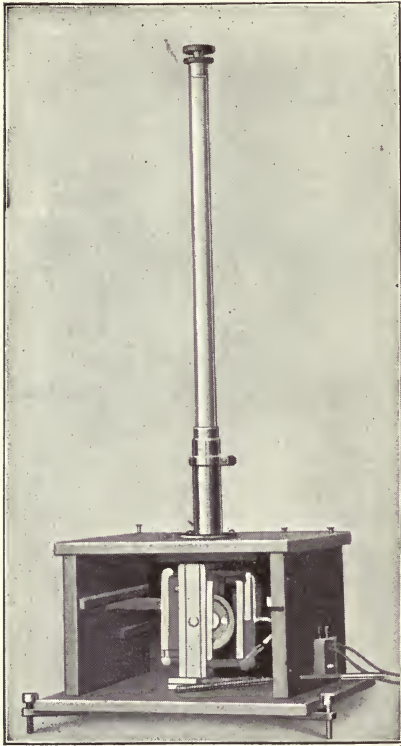

FIG. 170.

A "short-circuit loop dynamometer" (MANDELSTAM and PAPALEXI¹²⁹) has given very good results.

a. Its construction, for laboratory purposes is shown in Fig. 170, its diagrammatic connections in Fig. 171. There are two flat coils, S_1 and S_2 , perpendicular to each other and between the two, but coaxial with S_2 an aluminium loop or ring with a small mirror is suspended on a fine thread. The two currents I'_1 and I'_2 of Fig. 169 are sent through the coils S_1 and S_2 in order to measure their dynamometer effect. The resulting action is as follows: The current I'_2 , sent through S_2 induces a current I_3 , in the loop, which is in phase with I'_2 and proportional in amplitude to I'_2 , on condition that the inductance of the loop is greatly in excess of its resistance.¹³² The current in S_2 causes no turning force to act on the loop, as S_2 and the loop are coaxial. But the current I'_1 pass-

ing through S_1 induces no current in the loop as their planes are perpendicular to each other; it does, however, produce a torque upon the loop proportional to the dynamometer effect $\overline{I'_1 I_3}$ and hence also $\propto \overline{I'_1 I'_2}$.

This is true accurately only at the zero position of the loop. Careful analysis of the conditions, however,¹²⁹ has shown that even when the loop has been turned from its position of rest through a small angle, its deflection $\propto \overline{I'_1 I'_2}$. With the arrangement of Fig. 169, the deflection is

$$\vartheta = \zeta \cdot \frac{a \cdot \overline{I'_1 I'_2}}{b + \zeta \cdot c I'^2_{1ef}}$$

in which b is the torsion moment of the suspension system, ζ is the number of discharges per second and a and c are the constants of the apparatus. Hence $\vartheta \propto \overline{I'_1 I'_2}$.

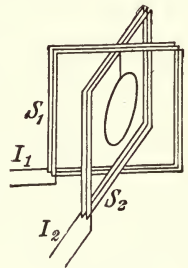

FIG. 171.

b. If the torsion moment of the suspension system is made very small (quartz thread), the factor b in the equation of paragraph a becomes very small in comparison to $\zeta \cdot cI'_{2\text{eff}}$. Then we have

$$\vartheta = \frac{a}{c} \cdot \frac{\overline{I'_1 I'_2}}{I'^2_{2\text{eff}}}$$

i.e., δ becomes independent of the discharge frequency, ζ , and thereby independent of the more or less irregular operation of the interrupter, if an induction coil or interrupted direct current is used.

3. USE OF RESONANCE IN THE STUDY OF CONDENSERS

84. Determination of the Frequency Factor.—The following will serve as a simple arrangement. Construct a primary circuit (condenser circuit I , Fig. 172), having that frequency at which the frequency factor of the

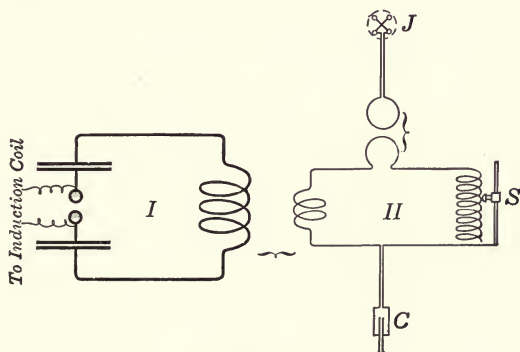

FIG. 172.

condenser is to be determined. Connect the test condenser, C , into a circuit containing a variable self-inductance, S , by means of which this condenser circuit, II , is brought into resonance with the primary circuit, I . Then replace C by a calibrated adjustable air condenser and vary its capacity until circuit II is again in resonance with the primary. Then the capacity, C , of the test condenser is equal to that of the air condenser at resonance. Now find the capacity, C_s , of the test condenser for static charges (see foot-note, Art. 72a). Then [Art. 5a], the frequency factor for the frequency in question is

$$f = \frac{C}{C_s}$$

This method is easily modified in numerous ways to adapt itself to any given case. The only essential feature is the replacing of the unknown capacity by that of an air condenser (which is independent of the frequency [Art. 5a]) and maintaining resonance.

In applying this method it is important to choose the coefficient of self-induction of circuit II so that the frequency will not be appreciably affected by the currents in the condenser coatings or by such slight changes in the leads to the condenser as may be necessary in view of the different construction of the air condenser and the various test condensers.

If it is desired to compare the frequency factors of a number of condensers having different dielectrics, the same electric field strength in the dielectric should be used in each case, as this may affect the frequency factor.

85. Energy Absorbed by Dielectric Hysteresis.²¹—*a.* The same arrangement as that of Fig. 172 applies. Assume the secondary circuit, II , which includes the test condenser, to be in resonance with the primary circuit and that the deflection of the measuring instrument in the indicating circuit is α' . The condenser, C , is then replaced by a variable air condenser which is adjusted until resonance is again obtained. Let α be the instrument deflection which now results. Then from these values and equation (2) Art. 76, we obtain the increase, d' , in the decrement of the secondary circuit caused by the energy absorption in the condenser C and which characterizes the *energy absorption of the particular dielectric material* [Art. 13].

b. For comparing various condensers it may be simpler to determine their *equivalent resistance* [Art. 77*b*] by substitution. For this purpose, after having replaced C (Fig. 172) by an air condenser and readjusted for resonance, sufficient resistance is connected into the secondary until the instrument deflection is again α' . This resistance, R' , is the equivalent resistance of the condenser.¹³³

c. In applying this method, which may be modified in various ways, it is especially important to avoid eddy currents in the condenser coatings. Their effect can entirely destroy the accuracy of the results. In condensers in the form of Leyden jars it is quite difficult to avoid eddy currents, or even to determine whether the eddy currents have been eliminated. A convenient safeguard, applicable only to plate condensers, however, is to place the condensers in various positions or to use first zinc sheet electrodes and then copper electrodes. If this causes no change in the instrument deflection it may generally be concluded that the existing eddy currents are negligible.

d. In comparing the energy absorption of different materials it is also important to use the same electric field intensity throughout in the dielectric, as this may affect the result. Similarly only values obtained at the same frequency should be compared.

86. The Brush Discharge of Condensers (W. EICKHOFF¹³⁴).—*a.* Curve *a* in Fig. 173 is the resonance curve of a condenser circuit whose condensers have no brush discharge; curve *b* was obtained with the same

circuit but with a heavy brush discharge from the condensers [Art. 14a]. The difference between the two curves is twofold, viz.,

1. b is not symmetrical, falling off much more rapidly on the side of the higher frequencies, while curve a is symmetrical.

2. The resonance point (maximum current effect) in b occurs at a lower frequency (greater wave-length) than in a .

Both these points are characteristic of condensers with brush discharge.

b . The explanation of this phenomenon is to be found in the following:

The brush discharge, by charging the uncoated portion of the condenser, causes an increase in its capacity and a decrease in the natural frequency of the circuit. The effect, however, is not the same as when another second condenser is joined in parallel to the coatings of the first through a metallic connection, for the conducting path between the coated and uncoated portions really consists of the brush discharge itself, which jumps from point to point very irregularly. Hence the amount of the charge held on the uncoated portion of the condenser is also continuously fluctuating. The irregularity of this parasitic capacity and its connection

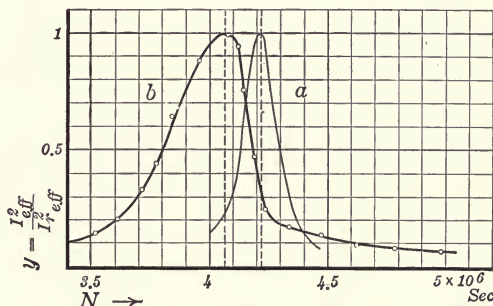

FIG. 173.

to the coated condenser will result in a varying frequency whose maximum value is determined by the capacity of the coated portion.*

Hence, if such a condenser circuit is caused to act upon a resonance circuit and if the frequency of the latter is gradually decreased, the current effect will rise with relative rapidity as soon as the maximum frequency just mentioned is approached. It will, however, retain comparatively great values as long as the frequency of the resonance circuit remains in the range of the frequency fluctuations caused by the brush discharge in the primary circuit. The result therefore is a widening of the resonance curve in the direction of the lower frequencies.

c . The widening of the resonance curve indicates a considerable reduction in the resonance sharpness;† it is caused mainly by the fluctuations in the frequency, as was shown in the preceding paragraphs.

Hence the amount of the energy loss due to the discharge can not be

* In all probability, these fluctuations in the frequency are accompanied by variations in the initial amplitude and irregularities in the fall of the amplitude during each oscillation.

† The resonance sharpness is about 24 for curve a and about 10.5 for curve b in Fig. 173.

determined [Art. 78a] from the resonance curves which give *only an upper limit* for the loss.

If the value $d_1 + d_2$ is obtained from the resonance curves by applying the relations of Art. 74, there being no brush discharge on the condensers, and the value $d'_1 + d_2$ is obtained with a brush discharge on the condensers, other conditions being the same, then the increase in the decrement due to the brush discharge can not be more than $(d'_1 + d_2) - (d_1 + d_2) = d'_1 - d_1$.

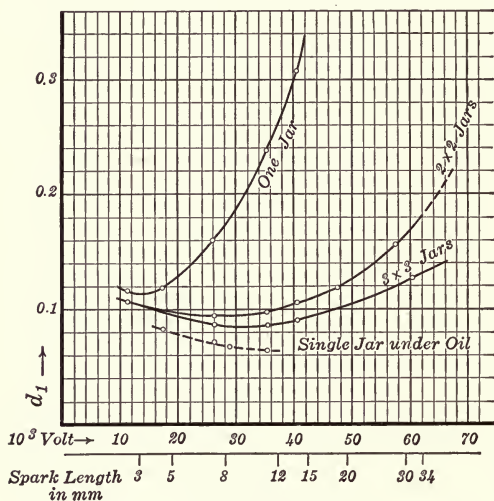

FIG. 174.

The result of measurements made in this way (W. EICKHOFF¹³⁴) is shown in Fig. 174 for Leyden jars of German flint glass.† The three full-line curves show the relation of d_1 to the potential amplitude, first with the capacity consisting of a *single* Leyden jar,‡ then with 2×2 Leyden jars,‡ connected as in Fig. 12, and lastly with 3×3 jars,‡ connected as in Fig. 13, the outer circuit remaining the same for each case. In the first case the entire potential difference exists between the con-

* The actual reduction in amplitude caused by the brush discharge does not come into question.

† M. WIEN¹⁷ has found the following apparent increase in the decrement due to brush discharge:

Potential amplitude	Leyden jars of English flint glass	Jars made by H. Boas.
0.9×10^4 volts	0.008	0.002
1.55×10^4 volts	0.028	0.002
2.2×10^4 volts	0.064	0.007

‡ All the jars had practically the same capacity, so that the resultant capacity in the various combinations remained just about the same.

However, the resonance curves may also be used for obtaining a *quantitative value* of the effect of the brush discharge on the sharpness of resonance. The equations of Art. 74 are applied to the curve and $d_1 + d_2$ is determined. Subtracting from this the decrement of the measuring circuit, d_2 , we have d_1 , which may be considered as being the decrement of a condenser circuit having no brush discharge but having the same *resonance sharpness*.*

denser coatings; in the second case only one-half; in the last case only one-third. The brush discharge is accordingly greatest in the first and least in the third case.

The uppermost curve shows how very detrimental the effect of brush discharge may be to the resonance sharpness. A comparison of the three curves shows that this harmful effect may be combatted by *series-parallel combinations of the condensers* [Art. 4d].

As a matter of fact, such series-parallel combinations of equal condensers can produce the desired result only if the apparent increase in the decrement due to brush discharge with increasing potential varies *more rapidly* than V_0^2 . If it $\propto V_0^2$, a simple consideration will make it evident that nothing is gained (L. W. AUSTIN ²¹) by series-parallel combinations. Above what potential the apparent decrement increase rises more rapidly than V_0^2 depends upon the form and material of the condensers.

d. As these series-parallel connections involve considerable complication, it is desirable to overcome brush discharge in some simpler way. This may be accomplished by placing the condensers, or at least the edges of their coatings, in a heavy oil. The extent to which this can reduce the detrimental effect of brush discharge is shown by the dotted curve in Fig. 174.

However, this is a dangerous method. For, if the voltages are not comparatively low,* the condensers are almost certain to break down. Bad as a brush discharge may be it has *one* good feature about it, namely, a *certain protection* against breaking down of the condensers.

e. From the preceding, we may draw certain conclusions of practical importance, viz.,

1. Displacement of the point of resonance [a_2], other things being equal, increases together with the potential amplitude, in fact is proportional to it under the conditions applying to such investigations as have been made. Hence, as brush discharge can not be entirely overcome in primary circuits, the tuning between primary and secondary must be done at the same potential at which the circuits will be used later.

2. The influence of brush discharge in cylindrical condensers becomes less according as the diameter is made smaller in comparison to the length, other things remaining equal, as this makes the parasitic capacity smaller in proportion to the normal capacity. Hence, from this point of view it is better to use *long, narrow* than short, wide jars.

3. Thickening the uncoated end of the condensers (Leyden jars) also reduces the parasitic capacity and the effect of the brush discharge (see Art. 39b).

* With the best flint glass, 5 mm. in thickness, 30,000 volts (corresponding to 1 cm. gap) is the extreme limit.

4. THE USE OF RESONANCE CURVES FOR INVESTIGATING COUPLED CIRCUITS

(J. ZENNECK,¹ C. FISCHER,⁹⁰ M. WIEN⁹⁰)

87. Coupling of Tuned Circuits.—Determination of Frequency, Decrement and Degree of Coupling.—If the oscillations of coupled, tuned circuits [Art. 55, *et seq.*] are caused to act upon a measuring circuit, resonance curves of the form shown in Fig. 175 will be obtained, if the circuits are quite *closely* coupled. The relations of Arts. 71 and 74 may be applied to both of the parts of these curves. The location of the two peaks gives the values of the frequencies N^I and N^{II} (and the wave-lengths λ^I and λ^{II}) of the two oscillations, the form of the curve around the two peaks gives the decrements d^I and d^{II} and the degree of coupling [Art. 95] is

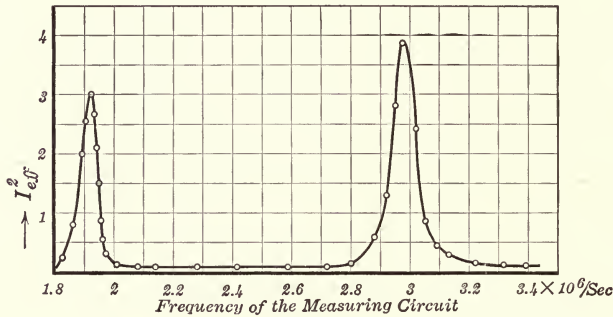

FIG. 175.

$$\begin{aligned}
 K' &= \frac{1 - \left(\frac{N^{II}}{N^I}\right)^2}{1 + \left(\frac{N^{II}}{N^I}\right)^2} = 1 - \left(\frac{N}{N^I}\right)^2 = \left(\frac{N}{N^{II}}\right)^2 - 1 \\
 &= \frac{1 - \left(\frac{\lambda^I}{\lambda^{II}}\right)^2}{1 + \left(\frac{\lambda^I}{\lambda^{II}}\right)^2} = 1 - \left(\frac{\lambda^I}{\lambda}\right)^2 = \left(\frac{\lambda^{II}}{\lambda}\right)^2 - 1
 \end{aligned}$$

in which N and λ are the frequency and wave-length respectively of both circuits before coupling.* If the coupling is not very close this may be simplified into

$$K' = \frac{\lambda^{II} - \lambda^I}{\lambda}$$

Table X gives the values of K' for different ratios of the frequencies.

With *loose coupling*, however, the resonance curves assume the shape

* If C^I , C^{II} and C represent the capacities of the measuring circuit corresponding to the wave-lengths λ^I , λ^{II} and λ , then $K' = \frac{1}{2} \frac{C^{II} - C^I}{C}$ 137

of the full-line curve in Fig. 176. The two peaks do not, in general, occur at the points corresponding to the two frequencies. Hence N^I and N^{II} (as well as λ^I and λ^{II}) cannot be determined from the location of the peaks, nor can the decrements be found by applying the methods of Art. 74. In this case we must proceed as follows.¹³⁶

a. The method in this case is based on the fact stated in Art. 61b that of the oscillations of the same frequency

$$\left. \begin{matrix} I_1^I \\ I_2^I \end{matrix} \right\} \text{ are approximately in phase.} \quad \left. \begin{matrix} I_1^{II} \\ I_2^{II} \end{matrix} \right\} \text{ are displaced approximately } 180^\circ.$$

This relation makes it possible to practically eliminate the effect of one of the pairs upon the measuring circuit, subjecting the latter only to the other pair.

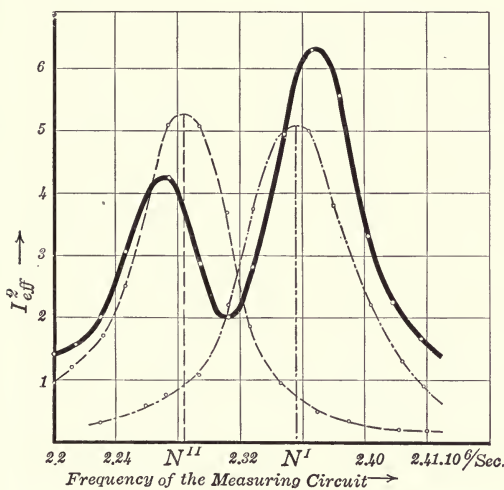

FIG. 176.

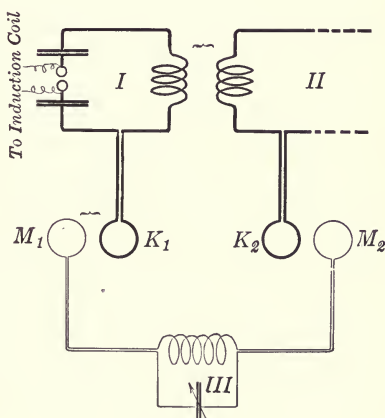

FIG. 177.

b. The arrangement is shown diagrammatically in Fig. 177. Small wire loops, K_1 and K_2 , are connected into the primary and secondary circuits respectively, and similar loops, M_1 and M_2 , are joined to the measuring circuit (III). K_1 acts inductively only upon M_1 , K_2 only upon M_2 .

The phase relations of the electromotive forces, E , are the same as for the corresponding currents, and we have approximately

$\left. \begin{matrix} E_1^I \\ E_2^I \end{matrix} \right\} \text{ in phase, } \left. \begin{matrix} E_1^{II} \\ E_2^{II} \end{matrix} \right\} \text{ displaced } 180^\circ.$ We will assume that these relations instead of being only approximate are exact.

The amplitude of these electromotive forces, aside from depending on the currents I_1^I , I_2^I , etc., also depend on the distances between K_1M_1 and K_2M_2 . If these distances are adjusted until the amplitudes of E_1^{II} and E_2^{II} are equal, then E_1^{II} and E_2^{II} will neutralize each other.

The result is that oscillation II (frequency N^{II}) has absolutely no effect upon the measuring circuit, which acts as if only the oscillation of frequency N^I and decrement d^I existed. Hence if the resonance curve is plotted in this way, it will represent only this one oscillation, and N^I or λ^I and d^I can be obtained from it in the usual way.

To obtain the opposite effect, that is, obviate oscillation I so that only oscillation II will be measured, all that is necessary is to revolve the loop M_1 (or else M_2) through 180° and then proceed just as before; E_1^I and E_2^I now neutralize each other while E_1^{II} and E_2^{II} are added to each other.

c. The *method of procedure* therefore is as follows. First a resonance curve is plotted, having, in general, two maxima. Then the distance between M_1 and K_1 (or M_2 and K_2) is varied until only *one* maximum remains in the resonance curve, all indications of the second peak having disappeared; the curve is then the resonance curve of one oscillation. Then M_1 is turned through 180° . If a trace of the former maximum remains, it should be eliminated by a final adjustment of the distance between M_1 and K_1 (or M_2 and K_2). The curve then is the resonance curve of the second oscillation.

The dash and dot-and-dash curves of Fig. 176 were obtained in this way. They are the resonance curves of the two oscillations; from them may be obtained the frequencies N^I and N^{II} , the decrements d^I and d^{II} and the degree of coupling K' .

d. In the *practical application*, the loops K_1 and K_2 may be entirely omitted, the primary and secondary circuits being used in their normal form to act upon M_1 and M_2 . The latter, however, *i.e.*, loops M_1 and M_2 , are best retained, as they simplify the manipulation. The following points should also be noted:

1. Moving M_1 (or M_2) must not change the self-induction of the measuring circuit. This is provided for by placing the leads connecting these loops to the rest of the circuit of wires very close together.

2. For *precise* measurements it is important to entirely eliminate the effect of the oscillation other than the one whose resonance curve is being determined. This can be done as follows: Assume oscillation II is to be eliminated, after an approximate value of N^{II} has been obtained as described above. The measuring circuit is adjusted to have this frequency N^{II} . Then the loops M_1 and K_1 are adjusted with respect to their relative position, until the electromotive forces E_1^{II} and E_2^{II} are *added* and the current effect in the measuring circuit becomes as *great* as possible. Only then is M_1 turned through 180° ; this procedure will result in a much more complete elimination of oscillation II than before.*

*The necessity for this precaution is due largely to the fact that the deflections of the measuring instruments which can be used for this purpose depend upon the mean *square* of the current value. Even when the effect of oscillation II is not

e. The accuracy of this method is very high so far as determinations of frequency and degree of coupling are concerned. But in view of the assumption made in *b* not being strictly correct, the values of the decrements d^I and d^{II} found in this way may involve considerable errors, the extent of which can hardly be fixed in each case (B. MACKŮ¹³⁸).

88. Close Coupling of Tuned Circuits. Current Effect in a Third Circuit.⁹⁰—Consider a secondary circuit tuned to and closely coupled to its primary and at the same time very loosely coupled to a third (measuring) circuit. Two questions present themselves, viz.,

1. How does the total current effect in the third circuit depend upon the latter's frequency?
2. If the third circuit is syntonized with one of the oscillations of

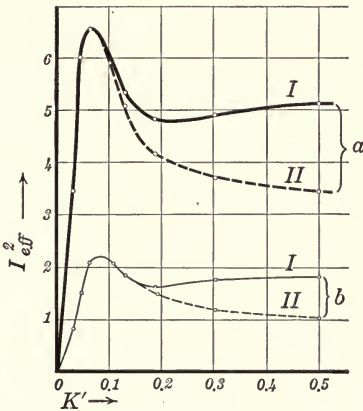

FIG. 178.

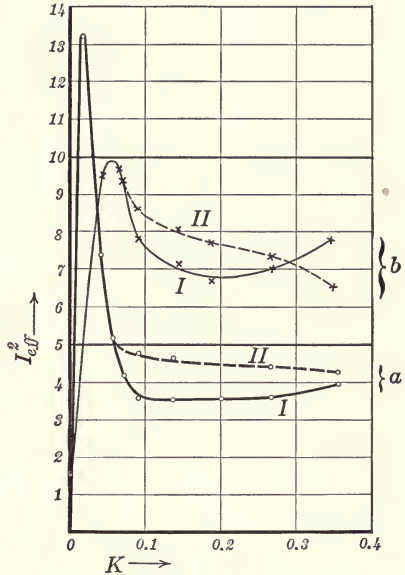

FIG. 179.

the secondary circuit, how does the current effect in the third circuit depend on the coupling between the primary and secondary circuits?

a. The answer to the first question follows directly from Art. 87. The heavy full-line curve of Fig. 176 shows how the current effect in the third circuit depends on the natural frequency of this circuit. Comparison with the dash and dot-and-dash lines (the resonance curves of the individual primary and secondary oscillations) shows that the maximum current effect in the third circuit does not occur when it has the same frequency as one of the oscillations in the secondary circuit. The maximum for the slower oscillation occurs at a somewhat lower frequency, that of the more rapid oscillation at a higher frequency.

The curves of Fig. 176 represent quite a loose coupling ($K' = 0.028$).

sufficient to show signs of a second maximum in the lower portion of the resonance curve of oscillation *I*, it may nevertheless greatly influence the shape of the upper part of the curve.

The closer the coupling becomes the more nearly do the maxima of the current effect in the third circuit coincide with the frequencies N^I and N^{II} of the oscillations in the secondary circuit.

b. The curves in Figs. 178, 179 and 180* show the relation of the current effect in the third circuit to the percentage of coupling, first with the third circuit tuned to the more rapid oscillation (*I*), then to the slower oscillation (*II*). These curves show:

1. In all cases there is a very decided maximum current effect for both oscillations, always occurring at a relatively very low frequency. The less the damping of the secondary and tertiary circuits, the more decided is the maximum.

2. Up to this maximum there is no noticeable difference between the more rapid (*I*) and

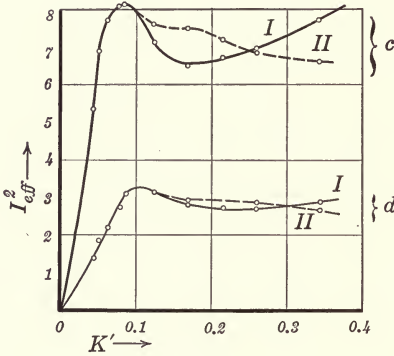

FIG. 180.

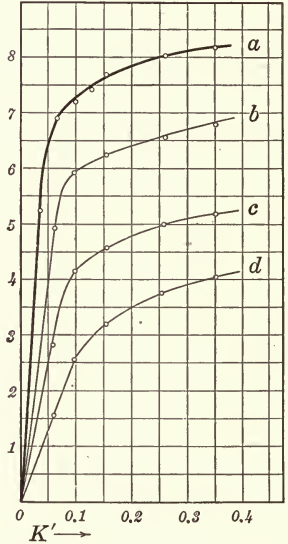

FIG. 181.

the slower (*II*) oscillation. But as the coupling is increased beyond the maximum, the oscillation of the higher frequency (*I*) may produce a considerably greater current effect than the slower oscillation.

The curves of Figs. 178, 179 and 180 were all obtained with primary circuits having a *spark gap*. The conclusion (2) just drawn from the curves would in fact not apply otherwise. If the primary circuit has *no*

* Fig. 178: $C_1 = C_2 = 0.85 \times 10^{-3} MF$. $L_1 = L_2 = 22,000$ cm.; $d_1 = 0.11$
 a: $d_2 = 0.14$ b: $d_2 = 0.20$
 $d_3 = 0.10$ $d_3 = 0.20$

Figs. 179 and 180: $C_1 = 5.29 \times 10^{-3} MF$. $L_1 = 6,230$ cm. $C_2 = 0.45 \times 10^{-3} MF$. $L_2 = 73,000$ cm. } $d_1 = 0.15$

Fig. 179a: $d_2 = 0.034$ Fig. 179b: $d_2 = 0.10$
 $d_3 = 0.031$ $d_3 = 0.10$

Fig. 180c: $d_2 = 0.21$ Fig. 180d: $d_2 = 0.37$
 $d_3 = 0.20$ $d_3 = 0.31$

Fig. 181: The letters correspond to the same conditions as in Figs. 179 and 180. Length of primary spark gap about 6 mm.

spark gap, theory⁹⁰ shows that the current effect must be the same for both oscillations.

c. It may at times be interesting to compare the current effect in a third circuit tuned to one of the coupling oscillations with the *total current effect in the secondary circuit*. The latter's variation with the coupling is shown in Fig. 181 for the same circuits referred to by Figs. 178, 179 and 180.

The use of *very short spark gaps* (less than 1 mm.) alters these conditions materially. In this case, as the percentage of coupling is gradually increased, the current effect in the secondary circuit may pass through a succession of maxima and minima. Careful investigation has shown that the maxima are due to particularly thorough quenching, the minima to particularly poor quenching in the gap of the primary circuit (H. RIEGGER).⁷

With thorough quenching in the primary gap, the current effect in the secondary may, under certain conditions, be greatest when the primary quenched gap circuit is slightly out of resonance with the secondary circuit.¹³⁹ This, however, is by no means universally the case; in many arrangements bringing the circuits out of resonance does not in the least increase the current effect obtained at precise resonance in the secondary.

89. Coupling Untuned Circuits. Current Effect in a Third Circuit (M. WIEN^{90, 92}).—Conditions are somewhat altered if the primary and secondary circuits have slightly different frequencies before being coupled, that is, are slightly out of resonance.

a. Theoretical investigation has led to the following conclusions for circuits *without spark gaps*. If the decrements d_1 and d_2 of the primary and secondary circuits are different before coupling, it is possible, by bringing the two circuits out of resonance, to obtain a current effect in one of the two oscillations which is greater than when the primary and secondary are exactly in tune.

1. If $d_1 < d_2$, we have two possibilities, viz., either the current effect of the more rapid oscillation (*I*) is increased when the primary has a higher frequency than the secondary, or the current effect of the slower oscillation (*II*) is increased when the secondary has the higher frequency.

2. If $d_1 > d_2$, what has just been stated for the more rapid oscillation, holds for the slower and *vice versa*.

The increase in the current effect is greatest for a certain dissonance. This amount of dissonance, other things being equal, increases as the difference between d_1 and d_2 increases and as the coupling is made closer. In general only about 20 per cent. increase in the current effect is the most that can be obtained.

b. *With a spark gap* in the primary circuit the relations, so far as can be concluded from such investigations as have been made to date, are *qualitatively* the same. But in general the strengthening of the current

effect is not quite so great as for primary circuits without a spark gap and under certain conditions the more rapid oscillation (I) seems to be the most favored.

90. Investigation of the Quenching Action in Spark Gaps.—The resonance curves of the current effect given in §1 are especially well adapted for studying the action of quenched gap circuits. For this purpose the secondary circuit coupled to the quenched gap circuit, is in turn coupled very loosely with a measuring circuit (Fig. 152) and the resonance curve of the current effect is plotted in this way.

a. If the resulting curve has the form of curve *b* in Fig. 182, the coupling oscillations are present and there is no quenching action. If, however, the result is like curve *a* of Fig. 182, this indicates complete quenching and only the natural oscillations of the secondary circuit are present. A resonance curve formed like curve *c* of Fig. 182 shows that in addition to the natural oscillations of the secondary, the coupling oscillations are also present.

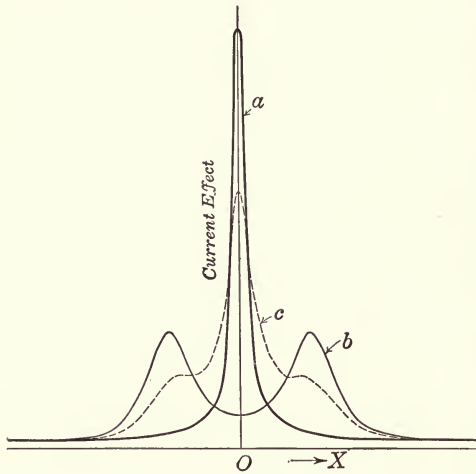

FIG. 182.

This may be due to any of three causes. Either the coupling oscillations occur at one discharge, and quenching occurs at another. Or the oscillations in the secondary circuit are always of the same kind, but the

quenching action is not complete, "impure," *i.e.*, the primary oscillations are not quenched until more than half an oscillation is completed [Art. 64a]. These two cases can be distinguished by coupling the secondary very loosely with a resonance circuit tuned to the natural frequency of the secondary circuit. A small spark gap is connected in parallel with the condenser in the resonance circuit and adjusted so as to respond regularly. This small gap is then placed alongside of the main quenched gap in the primary and both are observed in a rotating mirror. If the quenched spark gap is seen in the mirror first alone and then together with the small gap and so on, we evidently have the first case (H. RIEGGER¹⁴⁰).

The third possibility is the existence of a thorough quenching action, but a very loose coupling. Then the duration of half an oscillation and hence the time during which two coupling oscillations exist together [see foot-note to Art. 78c] is so great that the latter become apparent in the resonance curve.

b. From Art. 64 it follows that such observations as have just been described in *a*, offer a direct means of answering the question of the *critical degree of coupling* so important in practice, and thereby also the question of which of two spark gaps has the better quenching action. The coupling is made closer and closer; the critical and therefore the best degree of coupling is that at which the coupling oscillations have not yet appeared but are just about to become noticeable in the resonance curve.

It was stated in Art. 64*b* that, under certain conditions, several critical degrees of coupling, at which complete quenching is obtained, may be found. In such cases a comparison of various gaps as to their quenching action is very difficult.

c. The resonance curve also offers a simple means of determining whether a given method of increasing the quenching action (*e.g.*, air blowers, magnetic blow-outs, the use of hydrogen instead of air, etc.), is really effective¹⁴¹). First a condition of impure quenching, in which the coupling oscillations are evident in the resonance curve in addition to the natural oscillation of the secondary circuit (curve *c* of Fig. 182) is intentionally obtained. If then application of the method to be tested causes the indications of the coupling oscillations to disappear from the resonance curve, this is proof of an improved quenching action.

CHAPTER VI

THE ANTENNA

91. General.—Just as in ordinary wire telegraphy, so in radiotelegraphy, a system of communication is essentially comprised of two stations, viz., the “transmitting” and the “receiving” station. Similarly, the collection of apparatus used for sending off telegrams is called the “transmitter” or “transmitting set,” while the corresponding apparatus at the receiving station is termed the “receiver” or “receiving set.”

Every radio station has an open oscillator, the “antenna,” that part of the antenna which is suspended in the air being called the “aerial.” The transmitter induces electromagnetic oscillations in the aerial, whence electromagnetic waves are radiated in all directions; upon reaching the antenna of the receiving station these waves again produce oscillations in it, thereby causing the receiving apparatus connected to it, to respond.

If a dot of the Morse Code is to be telegraphed, the electromagnetic waves are sent out for only a very short instant, while if a dash is to be telegraphed, the waves are sent out for a somewhat longer period.

1. THE VARIOUS KINDS OF ANTENNÆ

92. Form of the Aerials.—*a.* The simplest form of antenna consists of a vertical wire suspended from an insulator: “simple antenna.” This is nothing more nor less than a straight lineal oscillator.

These simple antennæ are no longer used except in special cases, as, *e.g.*, with portable stations, on airships [Art. 96] and aeroplanes and where balloons or kites are used to carry the wire, thereby allowing the use of great lengths.

The successful use of the *streams of water* as simple antennæ (R. A. FESSENDEN¹⁴²), the stream being maintained by a pump, is mentioned mainly as a curiosity. Such antennæ, while very disadvantageous because of their high ohmic resistance* may nevertheless be useful in special cases of emergency (*e.g.*, in a fort or on a battleship whose normal antenna has been destroyed by the enemy’s fire).

b. The use of a large number of nearly vertical wires results in such

* A transmitter having worked 480 km. with a wire antenna 40 m. high, worked over a distance of 160 km. with a stream of water of about the same height as the wire antenna.

forms as the "harp" or "fan" aerial of Fig. 183* and the conical or pyramidal form of Fig. 184.† Fig. 185 shows a cross-section of a double cone or double pyramid antenna.

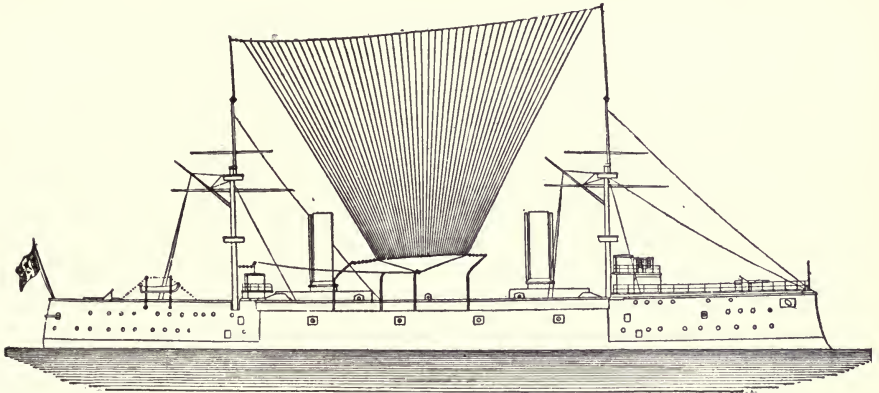

FIG. 183.

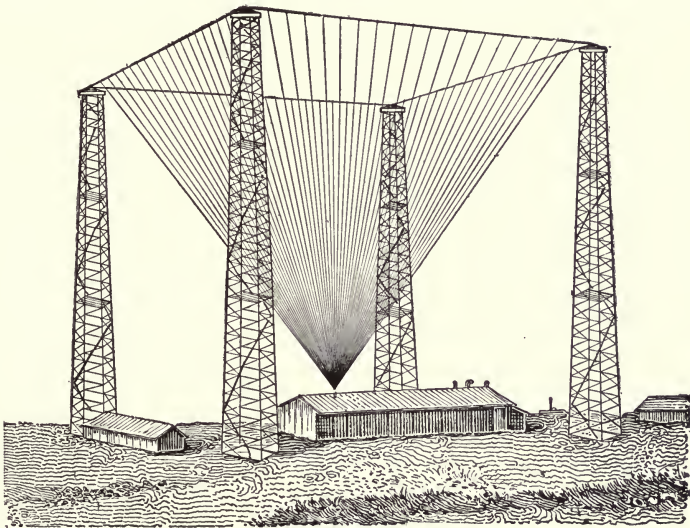

FIG. 184.

* The Italian Battleship "Carlo Alberto," with which *Marconi* made long distance tests in 1902 (see p. 117, ZAMMARCHI¹). The large Eiffel Tower Station has a harp-shaped aerial, stretched from the top of the tower. Of course this may also be considered merely as a sector of an umbrella antenna.

† The early Poldu Station of *Marconi* for long distances. This antenna was long in use for transmitting telegrams to vessels plying between Europe and America (see p. 105, ZAMMARCHI¹).

c. Antennæ having *very great capacity at their upper end*^{143,*} are now widely used, especially the so-called “**umbrella antenna.**” In its simplest form this consists of a vertical wire or bundle of wires, from the upper end of which wires radiate downward in all directions, sometimes extending quite near to the ground.

The form used by the TELEFUNKEN Co.¹⁴⁴ in 1910 for the construction of the *Nauen* Station is shown diagrammatically in Fig. 186. A tower

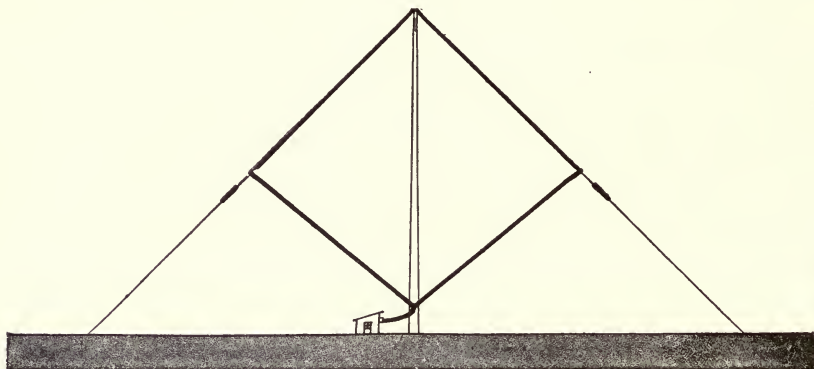

FIG. 185.

100 m. high, terminating below in a carefully insulated ball, serves partly to support the entire antenna and partly as a current carrier in conjunction with a bundle of wires with which it is connected.

In 1911 this tower was increased to a height of 200 m. (Fig. 187) the form of the second antenna being shown in Fig. 188. In April, 1912, during a severe storm this tower collapsed. Shortly after the construction of an entire new antenna and towers was undertaken.

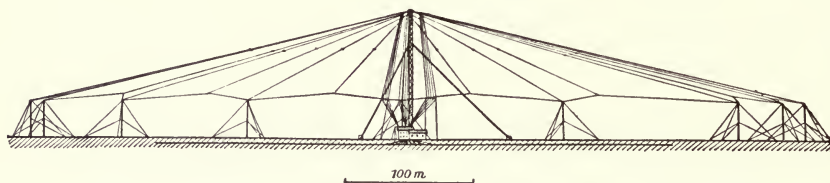

FIG. 186.

A similar antenna is that of the NATIONAL ELECTRIC SIGNALING Co.'s high-power station at *Brant Rock*¹⁴⁷ (height 130 m.) Its umbrella consists of eight cage-like wire structures 91 m. long and 1.2 m. in diam. Another similar antenna is that of the high-power station at *Eberswalde*, Germany (C. LORENZ).

* Probably first used by O. LODGE and A. MUIRHEAD¹⁴⁵) [Translator's Note]. The “*flat top*” antenna, such as that of the U. S. Naval Station at Radio (Arlington) also belongs to this class.

However, umbrella antennæ are also often used for portable stations. Many ingenious collapsible masts¹⁴⁸ of light weight have been devised for these, so as to be easily carried on pack-animals, wagons, etc., and requiring only a few minutes for erection and taking down.

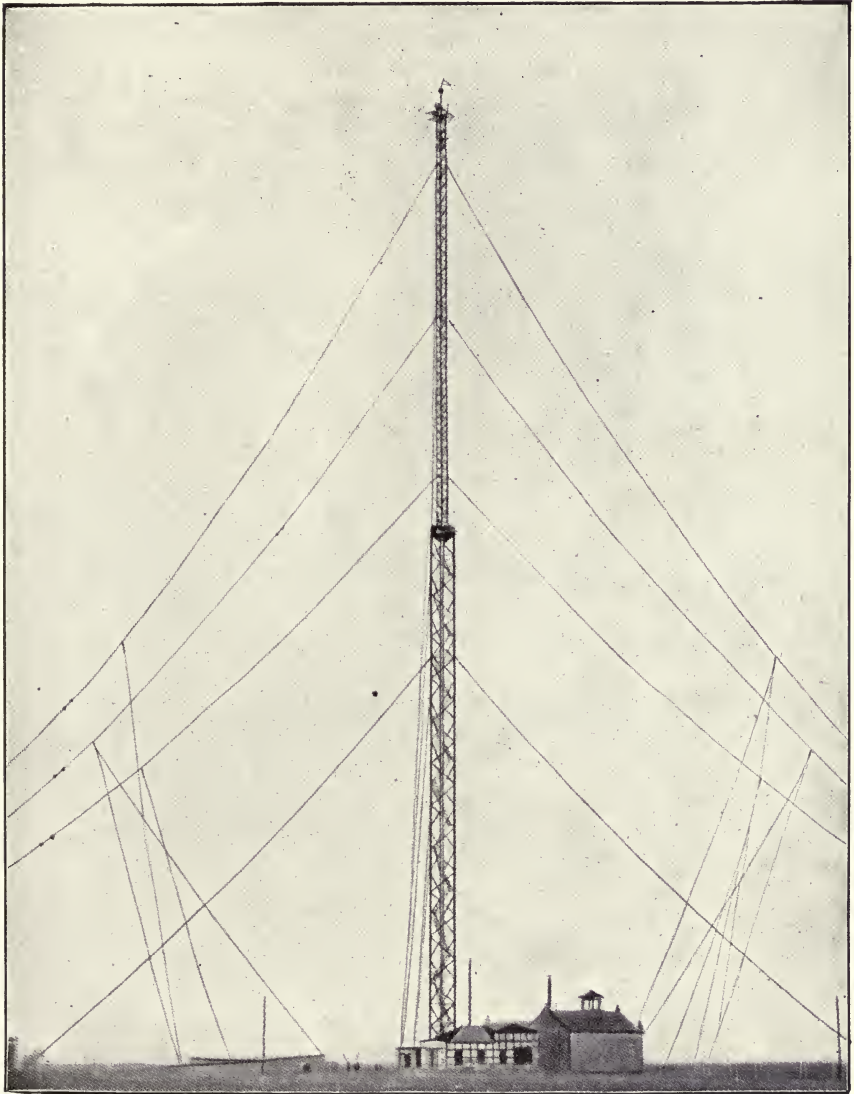

FIG. 187.

d. Antennæ consisting of vertical risers which are then prolonged horizontally at the top, usually as several parallel wires (Fig. 189: so-called "*F*" or more often, "*L*"-antenna; Fig. 190: so-called "*T*"-antenna),

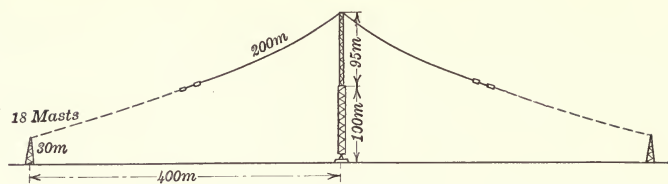

FIG. 188.

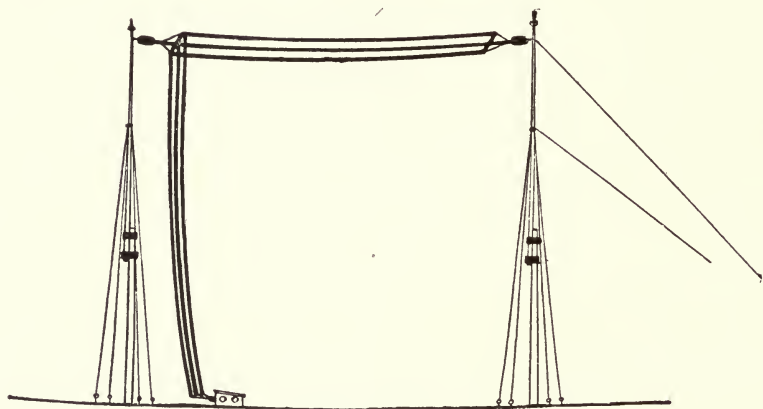

FIG. 189.

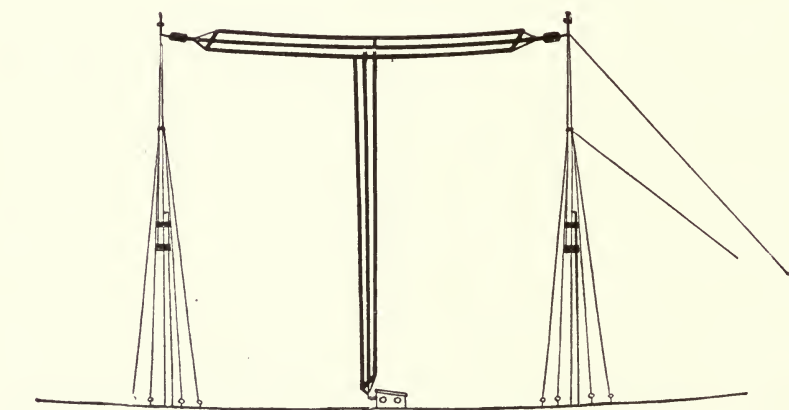

FIG. 190.

should also really be classified, within certain limits, among the antennæ having large end capacity. They are especially adapted for use on board ships, as the horizontal portion can be conveniently stretched between the masts. Battleships are now often equipped with the form shown diagrammatically in Fig. 190*a*.

A number of other forms, which may be considered as combinations of two of the forms already described, have also been proposed or actually used.

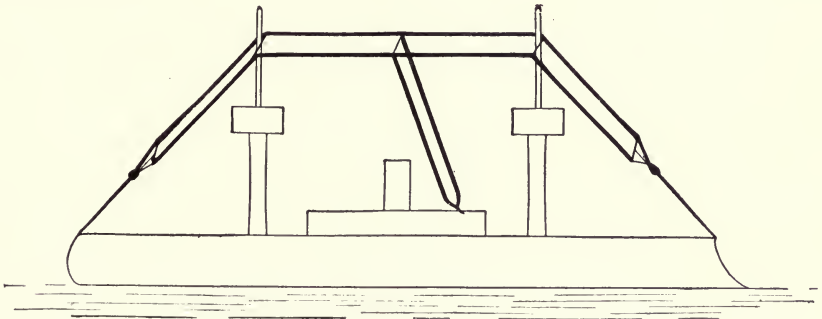

FIG. 190*a*.

93. Comparison of the Different Forms of Aerials.—*a*. It is evident that the *effective capacity* is greater in all of the various complex antennæ described than in a simple single wire antenna of the same height. It is greater according as:

1. The distance between (spacing of) the wires is greater in the vicinity of the potential anti-node and as
2. The distance from the wires to the ground is less at this part.

Both these factors give the umbrella antenna its very great capacity in comparison to other forms.*

b. The natural *frequency* of the complex forms described, in view of their greater effective capacity, is much lower, the natural wavelength therefore much greater than for a simple antenna of the same height.

c. As to the *current distribution*, there is usually a current anti-node at the base of the antenna. Thus Fig. 44 shows the current distribution for a simple antenna oscillating at its natural frequency; a current node is at the tip, and the current distribution is sinusoidal. If the wavelength of the oscillation is materially increased by inserting a coil (self-induction) near the base, only the upper and nearly straight portion of the sine curve remains [Art. 31*a*]. For conical and harp- or fan-shaped antennæ, the current distribution curve is not sinusoidal, but generally similar to the heavy broken line curve in Fig. 191.

* *e.g.*, the antenna of the *Nauen Station*, Fig. 186, had an effective capacity of about 0.018 *MF*.

A characteristic property of the umbrella type of antenna is the fact that the current, while flowing up through the vertical risers, flows down through the inclined radial wires. The current distribution in the vertical part is about as shown by the heavy broken line curve on the

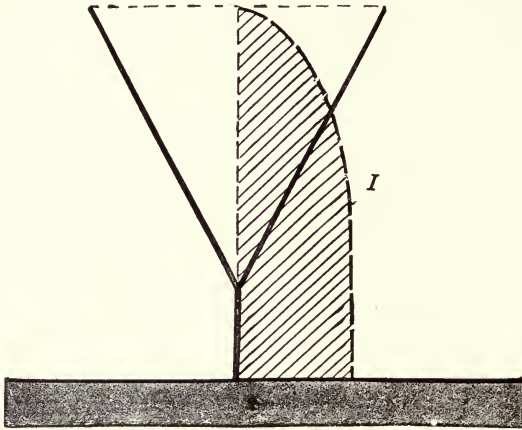

FIG. 191.

right side of Fig. 192, while in the inclined wires it is in general similar to the curve on the left side of Fig. 192;* in fact these forms remain practically unchanged, whether the oscillations are at the natural frequency or at a reduced frequency (increased wave-length) due to added coils.

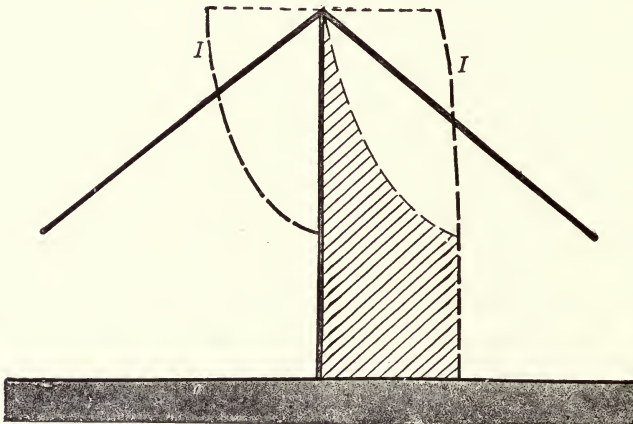

FIG. 192.

d. Comparing the various antennæ as regards *distance effect*, the height being the same for all, the factors which enter for consideration are [Art. 25]:

* The latter constructed by the method of Art. 25*d.*

1. The frequency (wave-length) of the oscillation.
2. The current amplitude at the current anti-node.*
3. The current distribution, hence the form factor.

Low frequency (great wave-length) is unfavorable for good radiation, but favors the propagation of the waves through space [Art. 139f].

A large effective capacity, giving a large current amplitude at the current anti-node* and a current distribution favorable to good distance effect is advantageous. In the umbrella antenna, however, the portion which is useful for producing distance effect is relatively small, as the currents in the vertical and the inclined portions tend to neutralize each other's effect, leaving only the shaded area shown in Fig. 192.

2. GROUNDING

94. Ground and Counterpoise. Effect upon the Current Distribution.

—If an aerial, say a simple, single wire antenna, were left with a free lower end, it would have a current node at the lowest point. This would make it quite difficult, to say the least, to produce strong oscillations in the antenna by charging it or by coupling it to a primary circuit.† Moreover, the conditions would in general be unfavorable. Two methods for avoiding this are in use, viz.,

1. Direct *ground connection* and
2. "**Counterpoise**," *i.e.*, a wire network, connected to the lower end of the antenna, parallel to, but *insulated* from the ground.¹⁴⁹

a. The result of a *ground connection* as explained in Art. 33, is the formation of an anti-node of current at the base of the antenna, if the ground is highly conductive. This is what virtually occurs with the waves of wireless telegraphy when sea water or very moist ground exists at the base of the antenna for a considerable distance around it. This is by no means true, however, if the station is erected upon very dry, *e.g.*, sandy ground or upon non-conducting rocks,‡ ground water being absent or existing only at a great depth. In such cases the anti-node of current will occur higher than the base, the height increasing as the conductivity of the ground circuit decreases.

b. The effect of the *counterpoise* upon the current distribution is not materially different from that of a direct "ground," no matter what the nature of the soil. We must distinguish between three cases:

* At a given potential amplitude—the same coupling with the same primary circuit.

† The spark gap [Art. 102a] or the primary circuit [Art. 53b] would have to be placed at a considerable height above the ground.

‡ One need only consider the fact that marble and slate are used in commercial light and power circuits as good *insulating materials* for potentials of several hundred volts.

1. The ground is a very good conductor.
2. The uppermost portion of the ground is a very poor conductor, but underneath this at a slight depth there is conductive ground water.
3. The ground is a very poor conductor and either there is no ground water at all or only at very great depth.

We are justified in assuming that a condenser of considerable capacity is formed in the first case by the counterpoise and the surface of the earth facing it and in the second case by the counterpoise and the surface of the ground water facing it. The insertion of such a capacity, however, either does not change the current distribution at all or it may raise the current anti-node somewhat [Art. 30].

The third case is identical with that discussed in Art. 29: an insulated conductor of great capacity is connected to the end of the antenna.

c. The *practical* method of *grounding* is particularly simple in the case of ships, which, in nearly all instances which come into question, are constructed of metal, so that connection to any portion of the ship's body usually suffices. For *land* stations, there are two methods mostly in use, viz.,

1. A metallic plate or cylinder (having a surface of, say, a few square yards) is buried in the ground or ground water; or

2. A very large wire network, circular or square shaped is laid either on top of or in the ground.*

The counterpoise, for both stationary and portable stations, is usually provided in the form of square or circular wire networks or radial wires in the shape of a star, fastened to poles a few feet (say 2 or 3) over the ground and insulated from it. For portable sets a rectangular strip of wire network, which can be alternately rolled up and unrolled and fastened to poles, is often used as a counterpoise.

95. Energy Consumed by the Earth Currents.¹⁵⁰—The electric field surrounding an antenna exists not only in the air, but also partly in the ground. Hence there must be currents in the ground which dissipate energy. It is impossible to generalize as to the extent of this energy consumption, which depends largely upon the form of the antenna, the frequency of the oscillations and the nature of the soil. The main points which come into consideration are about as follows:

a. Figs. 193–199† illustrate a number of cases diagrammatically, it being assumed throughout that there is a current anti-node at the base of

* The old counterpoise of the *Nauen* Station was a circular wire network 400 m. in diam., placed under ground at a depth of 0.25 m.

† These figures are not based upon any exact calculations, but are drawn from a general consideration of each set of conditions; therefore no reliance should be placed upon their precision. H. TRUE¹⁵⁰ has investigated the course of the ground currents in several cases. If the ground has extremely low conductivity, the electric lines of force may be inclined at an angle to the surface of the earth for a short distance just above the ground [Art. 139e].

the antenna. Comparing the use of a conducting network as "ground" and as "counterpoise," *i.e.*, Figs. 195 and 197 with Figs. 196 and 198, we find that it makes no difference qualitatively* so far as the course of the current lines is concerned, whether the network is buried in the earth as a "ground" or used as a counterpoise.

Both cases, however, are distinctly different from the case of grounding by means of a metal plate (Figs. 193 and 194). In the latter case *all* the lines of force pass from the antenna into the earth, each producing currents in the earth, while, where a network of conductors is used, a large number of the lines of force between the antenna and the network pass entirely or almost entirely through the air, thereby dissipating no energy.† Only those lines of force which reach the ground outside of the conducting network, produce currents in the earth. Hence, in this respect such networks are far superior to the use of relatively small metallic plates as grounds, the advantage increasing as the area of the network is increased.

From this point of view the umbrella antennæ (Fig. 199) are particularly advantageous. If the network is made large enough to extend considerably beyond the ends of the inclined radial wires of the umbrella, practically all the lines of force will pass

* However, there are quantitative differences.

† That is if we neglect the heat developed by the currents in the counterpoise, or in the case of a grounded network (Fig. 195) by the currents between the network and the surface of the earth.

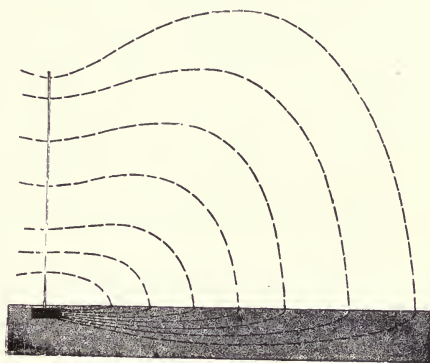

FIG. 193.

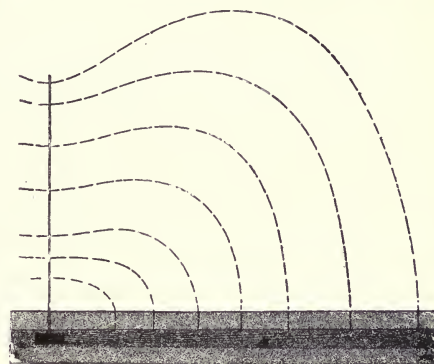

FIG. 194.

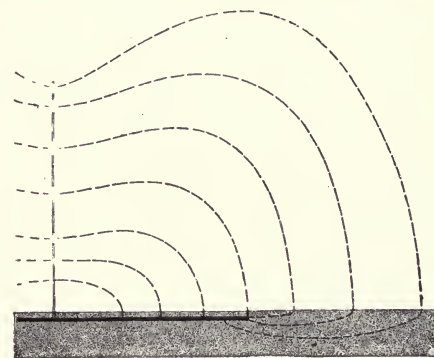

FIG. 195.

from the antenna to the network without first passing through the earth.

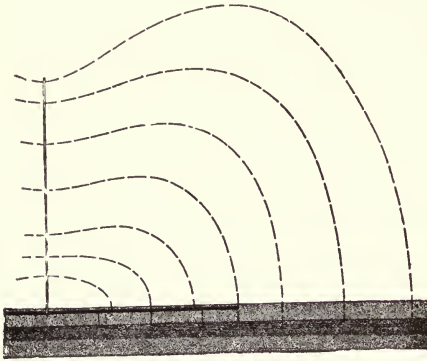

FIG. 196.

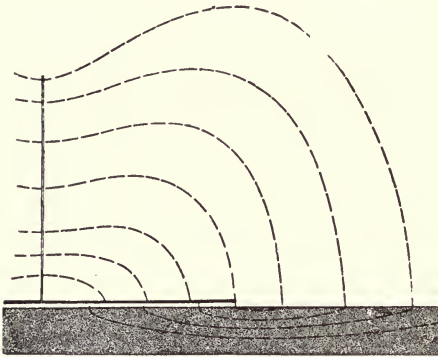

FIG. 197.

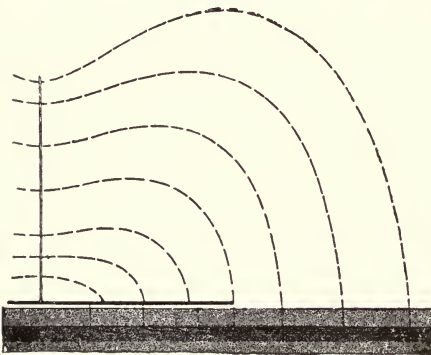

FIG. 198.

b. In Figs. 193, 195 and 197 it is assumed that the soil is homogeneous and has very low conductivity,* while Figs. 194, 196 and 198 are based on the assumption that a layer of ground water of relatively high conductivity is present at a short distance below the surface, underneath an upper stratum of very low conductivity. The difference lies mainly in that the lines of force choose the greater part of their path through the conducting layer of ground water, only a relatively short portion of their path being in the upper non-conducting layer. When grounding by means of a metallic plate, it is of great importance that the plate is placed at a sufficient depth to really reach the ground water (Fig. 194.)

c. It is also important that the lines of force are not crowded into a very narrow space at any point of their path, as this always involves a relatively great dissipation of energy.

For instance if an antenna is grounded through a single vertical wire, the current field, as seen from above, would be of the form shown in Fig. 200. If now, as is frequently done, the ground wire is replaced by a metallic plate, the current field assumes a far more advantageous form, about as shown in Fig. 201.

If the wire network is laid on the ground so as to be in (conduc-

* That is, ground water absent or present only at great depth.

tive) contact with it, the lines of force follow approximately the course shown in the cross-section drawn in Fig. 202 A_1 . If portions of the network do not make intimate contact with the ground, but are very close to it, the path of the currents is not materially altered (See Fig. 202 A_2). Fig. 203 shows the approximate course of the electric lines of force and

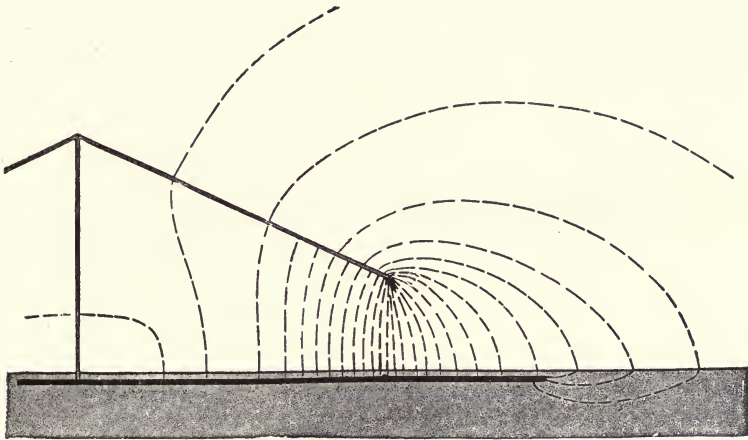

FIG. 199.

the currents, when a counterpoise is used instead of a direct ground. It certainly is the more advantageous method; the flow into the ground occurs just as if the network were replaced by a sheet of metal which is conductively connected to the earth at all points. There is no crowding of the current lines anywhere.

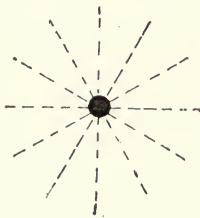

FIG. 200.

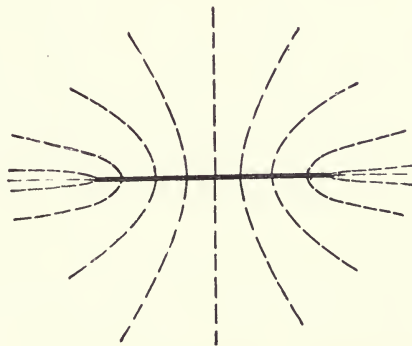

FIG. 201.

It is essential, however, that the conducting network which forms the counterpoise is really *insulated* from the ground. Faulty insulation at any point may come under either of two classifications. If the faulty insulation still offers a very *high resistance* (e.g., a damp porcelain insu-

lator), the general conditions will be affected but very slightly, although of course, there will be an additional loss of energy in the high resistance. But if the resistance is very low where the fault occurs (e.g., a spark discharge to ground) a very considerable portion of the current may pass to ground at this point, under very unfavorable conditions, similar to those shown in Fig. 200.

d. The *conductivity of the soil* plays an important part in determining the course and density of the ground currents as well as the energy they

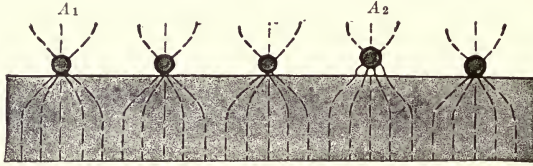

FIG. 202.

dissipate. In general, for a given form of antenna and a given frequency, there exists a *critical* value of the conductivity, at which the energy loss is a maximum. For any other conductivity, be it greater or lower than the critical value, the energy dissipation will be less.

A *change* in the conductivity of the ground as, for example, may be caused by varying weather conditions is apt at times to result in a change in the course of the earth currents, in the damping and possibly even in the frequency of the oscillations. The earth, therefore, introduces a variable factor into the entire system, no matter whether we use a direct

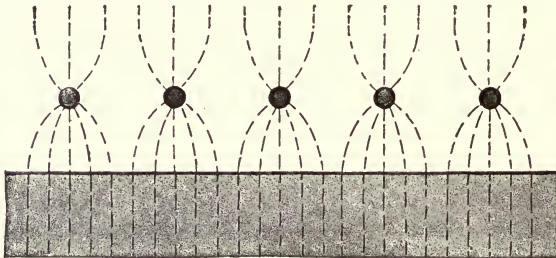

FIG. 203.

ground or a counterpoise. Only where the earth possesses very high conductivity (sea water, very wet soil) does the effect of the weather become negligible.

e. If we let R_e represent the equivalent resistance, of such value that $R_e I^2_{eff}$ is the energy consumed per second by the earth currents, I being the current amplitude at the base of the antenna, then it follows directly from *a* and *b*, that this ground resistance, R_e , must depend not only upon the nature of the soil and the method of grounding, but also upon all

those factors which determine the electrical field in the earth, and hence particularly upon the antenna form and the frequency of the oscillations. As regards the determination of R_e see Art. 100*d*.

Tests with an umbrella antenna have shown that R_e increases together with the frequency of the oscillations, but decreases as the height above ground of the counterpoise (when the latter is used) is increased. In all cases R_e was lower when using a counterpoise than when a direct ground of the form shown in Fig. 193 was used (H. TRUE¹⁵⁰).

96. Ungrounded Antennæ for Airships.¹⁵¹—*a*. The following forms of antennæ have been used among others, for airships, where grounding of any kind is entirely out of the question:

The antenna is a wire suspended from the car (or basket), which latter with its metal parts (motors, etc.), serves as counterpoise, insulated from the balloon body (the bag).

2. Similar to 1, except that the counterpoise includes the metal ribs or frame of the balloon (as in the Zep-pelin airships) or a conducting sheath of the balloon in addition to the car.

3. The antenna consists of two wires* of unequal lengths, somewhat on the order of LECHER'S arrangement (Fig. 204) (H. BEGGEROW): *e.g.*, one wire ($a_1 b_1$) is made equal to one-fourth of the wave-length of the oscillations, the other ($a_2 D$) = $\frac{3}{4}$ wave-length.

The oscillations are produced at *A* in the car; nodes of potential will then occur at *A* and *C* (see Arts. 72*c*2 and 24*a*). So far as radiation is concerned, only the part *BD*, which forms a simple lineal antenna, is effective, as the portions $a_1 b_1$ and $a_2 b_2$ neutralize each other.

4. For directive antennæ, adaptations of Fig. 416 have been suggested; the horizontal part is stretched out underneath the dirigible, parallel to its axis, while the two vertical antennæ are suspended downward.

b. With balloons there is ever present the danger of sparks between any parts of the balloon having considerable potential differences caused by the oscillations in the antenna when transmitting. †

Such differences of potential may be the result of various causes, thus:

1. If any part of the airship is conductively connected to the antenna, the oscillations of the latter are spread out over the entire metal structure of the airship. This results in differences of potential between individual

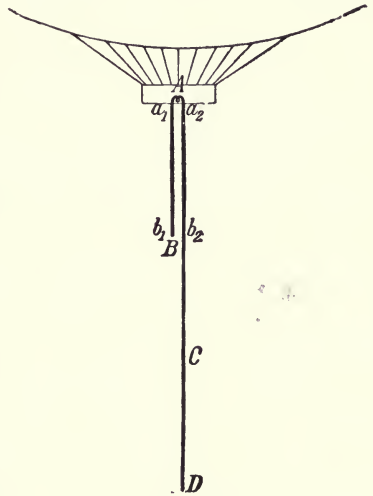

FIG. 204.

* Which are kept at the same distance apart throughout by insulating spacers.

† Normally, of course, the oscillations during reception are entirely harmless.

parts of the airship. To avoid these, it is advisable to join all neighboring metallic parts of the airship by the *shortest* possible connecting leads or bonds.

2. The electric field of the oscillations may produce differences of potential ("influence" action) between individual parts of the airship. This danger is greatly lessened by keeping the anti-node of current far from the airship.

3. The magnetic field of the oscillations may induce currents in the metal parts of the airship. In this connection a node of potential or anti-node of current in the antenna is particularly dangerous¹⁵².

In short there are so many possible tendencies for the production of a spark, that it is probably impossible to state in advance that any particular arrangement is spark proof. On the other hand, none of the arrangements described in *A* need be feared as placing an airship in any considerable danger.

In general, it may be stated that short wave-lengths are usually more dangerous than long ones, and that the danger diminishes with decreasing current and potential amplitudes. Accordingly arrangements involving a comparatively small amount of oscillating energy but having a high discharge frequency are advantageous when compared to those of equal total energy but using larger amplitudes (energy) for each oscillation at lower frequencies.¹⁵³

c. There is of course also the danger of *gas*, which has escaped from the balloon, becoming ignited by the *sparks* in the *gap* of the primary circuit. It is obvious that only completely enclosed gaps [*e.g.*, see Art. 111] should be used.

3. THE OSCILLATIONS OF ANTENNÆ

97. Frequency, Capacity and Self-induction.¹⁵⁴—*a.* To measure the natural frequency of an antenna, cause a loop or coil of wire inserted in the antenna to act inductively upon a measuring circuit, then proceed according to any of the methods already described [Art. 71]. A small spark gap in the antenna or preferably a quenched gap circuit or impulse excitation [see Art. 78] serves to produce the oscillations. Or a primary circuit having a known and variable frequency, is loosely coupled to the antenna and its frequency adjusted until a measuring instrument in the antenna gives the maximum deflection.

b. Frequency measurements may also serve for determining the *effective capacity*, *C*, and the *effective coefficient of self-induction*, *L*, of the antenna [Art. 27*a*], for example, as follows:

1. A coil of known self-induction, *L*₀, is inserted at the current anti-node. This will change the frequency *N* to *N'*, the wave-length λ to λ' . Then

$$L = L_0 \frac{N'^2}{N^2 - N'^2} = L_0 \frac{\lambda^2}{\lambda'^2 - \lambda^2} \text{ approx.} \quad (1)$$

Applying this value of L to the equation [Art. 27a]

$$N = \frac{1}{2\pi\sqrt{LC}}$$

or

$$\lambda = 2\pi V_L \sqrt{LC} \quad (2)$$

the value of C is obtained. .

2. A condenser of known capacity, C_0 , is inserted at the current anti-node. Then if the new values of the frequency and wave-length are N'' and λ'' respectively, we have,

$$C = C_0 \frac{N''^2 - N^2}{N^2} = C_0 \frac{\lambda^2 - \lambda''^2}{\lambda''^2} \text{ approx.} \quad (3)$$

Again applying the value of C to equation (2) we obtain L .

It is advisable to apply both methods 1 and 2, and use the average of the two values obtained for L and C . The greater the difference between N and N' or N and N'' the less will be the danger of inaccurate results, while if these differences are small, N , N' and N'' must be *determined with great precision*.*

c. Another method (C. FISHER), which however is neither so convenient nor so accurate,¹⁵⁵ consists in the insertion of a resistance R at the anti-node of current in the antenna and measuring the decrement before (d_1) and after (d_2) inserting R . Then we have for the difference of the two decrements

$$d = d_2 - d_1 = \pi R \sqrt{\frac{C}{L}} \quad [\text{Art. 27a}]$$

Combining this with equation (2) which gives the product $C \times L$, we obtain both C and L .

98. Regarding the Effect of Coils and Condensers in Antennæ.—a. The insertion of *coils* (inductance) lowers the frequency, hence increases the wave-length,† decreases the form factor and, with a given potential

* The following are typical antenna *capacities* mentioned in the literature of wireless telegraphy.

Torpedo boat antenna	$C = \text{approx.}$	$1 \times 10^{-3} \text{ MF.}$
Cruiser, battleship antenna	$C = \text{approx.}$	$2 \times 10^{-3} \text{ MF.}$
Brant Rock high-power station	$C = \text{approx.}$	$7 \times 10^{-3} \text{ MF.}$
Nauen high-power station	$C = \text{approx.}$	$18 \times 10^{-3} \text{ MF.}$
Eiffel Tower high-power station	$C = \text{approx.}$	$7.3 \times 10^{-3} \text{ MF.}$

The *self-induction* used in antennæ is usually much greater than that of the aerial proper due to inductive coils in the antenna circuit. The self-induction of the Brant Rock aerial is given as 55,000 *C.G.S.* units, that of the Eiffel Tower as 196,000 *C.G.S.* units.

† This is often expressed as “lengthening the antenna” (aerial) by means of a coil and “shortening” it by a condenser.

amplitude, decreases the current amplitude [see Fig. 47, Art. 31]. All these effects tend to reduce the radiation and also the radiation decrement.

The insertion of a condenser at the base of an antenna has the opposite effect, in so far as it increases the frequency, hence decreases or shortens the wave-length* and at the same time the anti-node of current is raised upward from the base of the antenna [Art. 30]. The form factor is thereby made more favorable for distance effect. As to the change in

the current amplitude with respect to the potential amplitude and as to the resultant change in the distance effect and radiation decrement, it is hardly possible to draw any conclusions to cover all the various forms of antennæ.

By inserting both a *coil* and *condenser* in series, these can be so chosen for any given aerial as to avoid any change in the wave-length, only greatly reducing the radiation decrement (**"Antenna with reduced radiation damping"** [see Art. 32b].

b. Instead of using just coils, the wave-length of an antenna can be greatly increased by means of the arrangement shown in Fig. 205.† A coil, L , whose self-induction is very great as compared to that of the aerial and the connection to ground is inserted in series with the antenna and the condenser, C , is joined in parallel to it. We are justified in considering this arrangement, as used in practice, as forming a condenser circuit whose self-induction is practically that of the coil L and whose capacity consists of the condenser C in parallel with the capacity formed by the aerial and ground. A little consideration will make it evident that such an arrangement has a materially lower

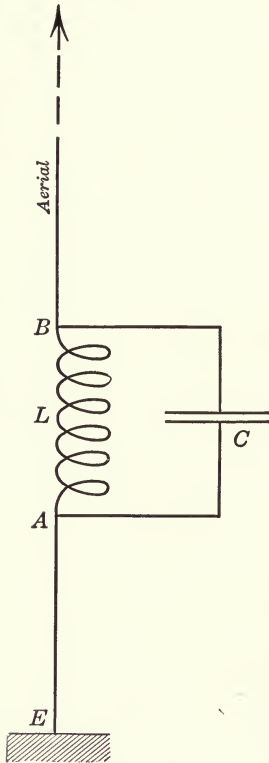

FIG. 205.

radiation decrement than the antenna alone.

c. These arrangements have found practical application as follows:

1. In order to make the advantage of long waves for propagation available, it is customary to use coils of considerable self-induction in antennæ, either alone or in conjunction with condensers (**"Lengthening Coils"**) [see, *e.g.*, the coil marked 28 in Fig. 236].

2. Coils of adjustable self-induction at times together with condensers, or condensers of adjustable capacity alone are universally used for tuning

* This is often expressed as "lengthening the antenna" (aerial) by means of a coil and "shortening" it by a condenser.

† This is sometimes called the "fly-wheel" method.

antennæ to a desired wave-length (“tuning coils,” “tuning condensers,” “aerial variometers”).

3. To obtain different wave-lengths with the same antenna, a condenser, at times with a coil in series, is so connected that it may be cut into (short waves) or out of (long waves) the antenna by means of a switch. Or a switch is arranged by means of which the condenser is connected in series with the aerial for short waves (Fig. 206) and in parallel to the coil (Fig. 205) for long waves.

99. The Damping of Antennæ and Its Causes.—*a.* Only that portion of the energy which, during the oscillations of an antenna, is sent out in the form of electromagnetic waves, may be considered as **useful energy**. If then we wish to speak of the “**efficiency**” of an antenna, meaning thereby the relation of the useful energy to the total energy supplied, at the fundamental oscillation, this would be

$$\eta = \frac{d_{\Sigma}}{d}$$

i.e., the ratio of the radiation decrement to the total decrement.*

b. All other losses of energy which occur during the oscillation, are more or less necessary evils. These include:

1. Joulean heat in the antenna.
2. Joulean heat of the earth currents.
3. Joulean heat of the induced currents.
4. Losses due to brush (leakage) discharge.
5. Circuit losses.

The development of *heat (Joulean)* in the wires of the aerial, in the tuning and lengthening coils, in the ground circuit, in the counterpoise and in the various leads, has a considerable effect upon the decrement of such antennæ whose radiation decrement has been much reduced.

Hence for well-designed antennæ it is customary to use braids of *very* fine, individually insulated wires, or bands or strips consisting of several such braids in parallel and interwoven, in order to reduce the ohmic resistance to a minimum.†

* COUNT V. ARCO¹⁵⁷ estimates the efficiency of a properly constructed ship antenna at 50 per cent., if the wave-length is increased by the factor 1.3 by means of inserted coils.

† COUNT V. ARCO¹⁶⁰ gives the following data:

2 kw. station: effective current at base of antenna, 13 amp.; antenna resistance, 6 ohms; 480 single wires in parallel.

8 kw. ship station: effective current at base of antenna, 35–40 amp.; antenna resistance 3 ohms; 3000 wires in parallel. To provide the necessary tensile strength copper-sheathed steel wires [Art. 36c] and also bronze wires are often used.

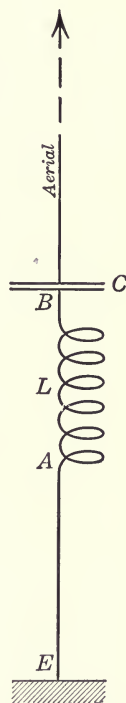

FIG. 206.

The portion of the total decrement due to the *earth currents* may at times be as large as the radiation decrement. Even in spite of the greatest precautions in grounding, in the attempt to keep this portion of the decrement at a minimum the results will depend ultimately upon the nature of the soil. Such results as can be obtained at sea are probably never attained over poorly conducting ground.¹⁵³

Induced currents come mainly into question in guys, stays, iron masts and similar metal parts on board ships, and in the towers supporting the antennæ and their guys in land stations. Experience has shown that these currents, which always mean a waste of energy, may harm the radiation considerably and be generally detrimental. A method of counteracting the bad effect of these currents is to insert insulating links in the conductors affected, or, in any case, insulating them from ground. This was very well provided for in the old Nauen antenna [Art. 92c]; the only conducting parts in which currents could be induced were the three guys holding the tower and these were well insulated from the tower at their upper ends and from the ground below.¹⁵⁹

It is well known that the brush or leakage discharge, which at night is visible over a large part of the antenna, has a very bad effect upon the

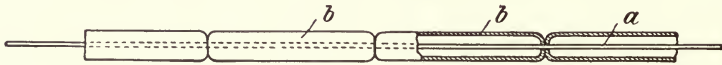

FIG. 207.

decrement; it is therefore important to avoid sharp points and edges in the aerial. As increased surface (larger radius of curvature) for the conductors tends to reduce the brush discharge, it has been proposed to surround the antenna wires by metal piping or tubing joined conductively to the wires (Fig. 207), or else to use metal bands or strips, preferably having rounded edges, wound around rope, as the aerial conductors. The use of well-insulated high-tension cable instead of bare wire is perhaps even more effective. *Specially designed insulators*¹⁵⁹ to prevent brush discharge are frequently used at the ends of the wires.

*Circuit losses** may of course occur in any oscillator such as, *e.g.*, a condenser circuit. They have not been previously discussed for the reason that they are easily prevented in all other forms of oscillators and hence are of no importance when ordinary precautions are taken. With antennæ as used in radio-telegraphy, however, the prevention of circuit losses, in view of the high potentials involved and the severe weather effects¹⁵⁶ is a much more difficult matter.

100. Determination of the Decrement.—*a.* Any of the methods already given may be applied to find the *total decrement* of the natural oscillations; a quenched gap circuit offers a suitable means for excitation.

* This is intended to include losses due to spark discharges (to ground, etc.).

The value of the total decrement for various forms of antennæ under normal conditions (good grounding, thorough insulation), there being no coils of great self-induction inserted, runs about as follows:

Simple antenna (single straight wire, airship antenna)	0.25-0.3
Harp- or fan-shaped antenna	0.2
Conical or double-cone antenna	0.16-0.18
Umbrella or ship (<i>T</i>) antenna	0.12-0.16

As a matter of fact, inductive coils are always inserted. If their coefficient of self-induction is not sufficiently large to materially affect the frequency of the oscillations, the decrement, for umbrella and *T*-aerials will be about 0.1. But if the wave-length is increased to three or four times its original value by means of inductance inserted in these forms of antennæ, the total decrement can thereby be reduced to 0.05-0.03.

b. The *effective resistance*, *R*, can be calculated, if the total decrement, *d*, is known, from the equation

$$d = \pi R \sqrt{\frac{C}{L}} \quad [\text{Art. 27a}]$$

if *C* and *L* are also known.

R may also be found by causing an undamped primary circuit to act inductively upon the antenna and then proceeding as per Art. 76b.¹⁶¹

The following ("artificial aerial") method has also been widely used:

A primary circuit (quenched gap circuit or undamped oscillations) can be loosely coupled by means of the switches *U*₁ and *U*₂ (Fig. 208), either with the antenna (*E*-*S*₂-aerial) or (dotted position of switches) with a condenser circuit *S*₂*S*'₂*C**R*, having the same capacity and self-induction as the antenna, but, in addition, a variable resistance, *R*. The latter is adjusted until the ammeter, *A*, gives the same reading (current effect) with either the aerial or the condenser circuit. Then the resistance of the condenser circuit = the desired effective resistance of the antenna.

In order that the resistance of the condenser circuit may be easily determined, it is advisable to so construct it that its resistance shall be very small as compared to that of the variable resistance *R*, the latter being made of such wires and so designed that its effective resistance = its D.C. resistance [Art. 36*b*], so that it may be measured with direct current.

c. It is particularly interesting to separate the *radiation resistance* from the other parts that make up the total resistance.

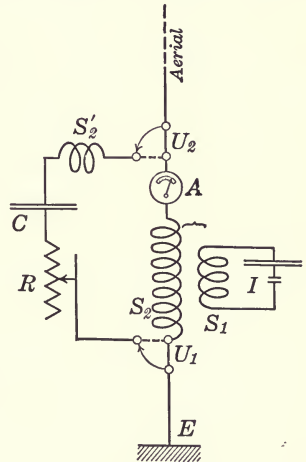

FIG. 208.

If the form factor of an antenna has been found by current measurements and the antenna stands on soil of good conductivity, the radiation resistance can usually be *calculated* with sufficient accuracy.

In this case the field of the grounded antenna (height, h) over the surface of the earth is identical with the field which would result from the antenna and its "image," *i.e.*, an oscillator whose total length $l = 2h$, there being no ground present. The only difference is that the energy radiation of the grounded antenna is only one-half the radiation of this oscillator, as in the former the lower half is missing [Art. 33].

Hence if, according to Art. 26*b*, the radiation resistance, R_{Σ} , of this oscillator of length l is given by

$$R_{\Sigma} = \frac{8\pi^2}{3} \times \left(\frac{\alpha l}{\lambda}\right)^2 \times 3 \times 10^{10} \text{ C.G.S.}$$

then for the grounded antenna this must be

$$\begin{aligned} R_{\Sigma} &= \frac{1}{2} \cdot \frac{8\pi^2}{3} \cdot \left(\frac{2\alpha h}{\lambda}\right)^2 \cdot 3 \times 10^{10} \text{ C.G.S.} \\ &= 160\pi^2 \left(\frac{\alpha h}{\lambda}\right)^2 \text{ ohms*} \end{aligned}$$

in which α has the values given in Art. 25*c*. With sinusoidal current distribution (simple antenna) $R_{\Sigma} = 36.6$ ohms [Art. 26*b*].

The following is an *experimental* method (A. ERSKINE-MURRAY, M. REICH¹⁶²) for approximately determining the radiation resistance of a transmitting antenna. At a distance, r , of at least several wave-lengths from the transmitting aerial, a tuned receiving aerial is erected and the current effects $I_1^2_{eff}$ and $I_2^2_{eff}$ determined at the bases of the sending and receiving antennæ respectively. The height of the transmitting aerial is then altered a little (say, by simply raising or lowering the aerial wires slightly by means of ropes) and the measurements repeated, giving the new values, $I_1^2_{eff}$ and $I_2^2_{eff}$. The discharge frequency and wave-length must be retained constant. This method assumes that the electric field at the distance of the receiving antenna, and also the ground resistance near the transmitter are not appreciably changed by the change in the height of the aerial wires—an assumption which of course is not always correct.

Under these conditions we then have the following relations:†

Conceive a sphere of radius, r , surrounding the transmitting antenna. Then the energy which passes through a square centimeter of the surface of the sphere per second $\propto E^2_{eff}$, E being the electric field strength at the point in question [Art. 26]; it also $\propto E_2^2_{eff}$, E_2 being the electric field

* = $160\pi^2 \left(\frac{h'}{\lambda}\right)^2$ ohms, if $h' = \alpha h$ is the effective height of the antenna.

† What follows is based on the assumption of good conductivity of the soil. The results, however, are not dependent upon this assumption.

strength at the receiving antenna, or it $\propto \mathcal{E}_{eff}^2$, \mathcal{E} being the potential difference¹⁶³ acting along the length of the receiving antenna.

Hence, the total energy which passes through the entire surface of the sphere each second also $\propto \mathcal{E}_{eff}^2$. On the other hand it is $= R_{\Sigma} \cdot I_1^2$ [Art. 26]. Hence we obtain

$$R_{\Sigma} = a \frac{\mathcal{E}_{eff}^2}{I_1^2}$$

The relation of I_2 to E depends upon whether the oscillations of the transmitting antenna are damped or undamped. In the latter case

$$I_2 = \frac{\mathcal{E}}{R_2} \text{ [Art. 67 b]}; \quad I_2^2 = \frac{\mathcal{E}_{eff}^2}{R_2^2}$$

hence, we may write

$$R_{\Sigma} = b \cdot \frac{I_2^2}{I_1^2}$$

But if the antenna oscillations are damped, then

$$\mathcal{E}_{eff}^2 = \frac{\zeta \cdot \mathcal{E}_0^2}{4Nd_1} \text{ [Art. 44a]}$$

$$\begin{aligned} I_2^2 &= \frac{\zeta \cdot \mathcal{E}_0^2}{16N^3L_2^2} \cdot \frac{1}{d_1d_2(d_1 + d_2)} \text{ [Art. 70, Equation (1)]} \\ &= p \cdot \frac{\mathcal{E}_{eff}^2}{(d_1 + d_2)} \end{aligned}$$

and

$$R_{\Sigma} = d(d_1 + d_2) \cdot \frac{I_2^2}{I_1^2}$$

If now we let R and R' represent the effective resistance of the transmitting antenna during the two measurements respectively, and R_0 , that part—constant by our assumption—which is not due to the radiation decrement, then for undamped oscillations we have

$$\left. \begin{aligned} R &= R_0 + R_{\Sigma} = R_0 + b \cdot \frac{I_2^2}{I_1^2} \\ R' &= R_0 + R'_{\Sigma} = R_0 + b \cdot \frac{I_2'^2}{I_1'^2} \end{aligned} \right\} \quad (1)$$

and for damped oscillations

$$\left. \begin{aligned} R &= R_0 + d(d_1 + d_2) \cdot \frac{I_2^2}{I_1^2} \\ R' &= R_0 + d(d_1' + d_2') \cdot \frac{I_2'^2}{I_1'^2} \end{aligned} \right\} \quad (2)$$

* a , b , d and p are factors of proportionality. This d should not be confused with the decrements.

Subtracting one equation from the other, we obtain b or d and thereby the radiation resistance, R_{Σ} , having previously determined the total effective resistance, R and R' and also, when damped oscillations are used, the sum of the decrements $[(d_1 + d_2)$ and $(d'_1 + d_2^*)]$.

A test of whether the assumptions upon which the preceding equations were based hold approximately true in a given case can be obtained by repeating the measurements at one or two different antenna heights; the additional equations so obtained should give the same resulting values for b and d .

d. Having determined the radiation resistance R_{Σ} and the effective resistance R_j of the aerial wires, as well as the total antenna resistance R , then from

$$R = R_{\Sigma} + R_j + R_e,$$

the value of R_e follows. This, for antennæ on firm ground, seems to amount to at least several ohms,¹⁵⁰ but depends entirely upon the form of the antenna, the frequency of the oscillations, the nature of the soil and the method of grounding.

* If d_1 and $d'_1 \ll d_2$, equation (1) may be applied to damped oscillations also.

CHAPTER VII

TRANSMITTERS OF DAMPED OSCILLATIONS

101. **The Different Types of Transmitter.**—There are two methods, customarily applied for producing the oscillations in the antenna, viz.,

a. A spark gap is inserted in the antenna and the latter is charged by means of an induction coil or its equivalent. The antenna discharges across the gap, during which discharge the antenna oscillates in its natural period. This is the “**simple**” or “**Marconi transmitter.**”

b. The antenna is coupled to a condenser circuit. This gives rise to two possible cases, viz.,

1. Two coupling oscillations are produced in both the condenser circuit and the antenna—the “**Braun transmitter,**” or

2. The oscillations of the condenser circuit are quenched after a few cycles and the antenna continues to oscillate with its own damping—the “**quenched spark gap**” or “**Wien transmitter.**”

1. THE SIMPLE (MARCONI)* TRANSMITTER

102. **General.**—a. The antenna has a spark gap, *F* (Fig. 209) at the bottom.

It is advantageous to have an *anti-node of current at the foot of the antenna*, for, with a given voltage, this will make the current amplitude of the fundamental oscillation a maximum and the spark damping a minimum, with the spark gap lying in an anti-node of current. This condition is no doubt always obtained in practice by grounding.

b. The *combined* or *multiple* forms of *aerials* [see Art. 92] increase the effectiveness of the MARCONI transmitter. For the same height, their effective capacity is much greater and if their form is properly chosen, the current distribution along the antenna is much better than with the simple aerial. Both these differences are factors favoring increased distance effect at a given voltage [Art. 93*d*].

* MARCONI now also uses the coupled BRAUN transmitter exclusively or at least, mainly, for damped oscillations. *However, it was with the simple form of transmitter that he attained his first successful results and demonstrated the possibility of wireless telegraphy by means of electromagnetic waves over great distances.*

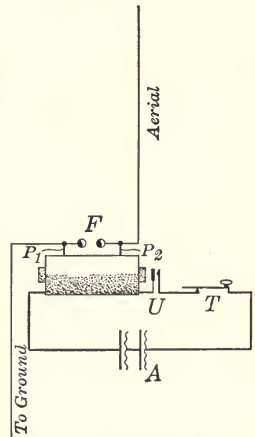

FIG. 209.

103. The Damping.—*a.* Any of the spark methods of excitation inherently involve a *consumption of energy in the spark* in addition to the energy losses occurring in antennæ without spark gaps. Accordingly, the efficiency is not as high as for an antenna without a gap. If we define the efficiency, as in Art. 99*a*, as the ratio of the energy radiated by the fundamental oscillation in useful form to the total energy consumed by it in the same time, we have

$$\eta = \frac{d_{\Sigma}}{d + d_g}$$

where d is the decrement of the antenna without the gap and d_g is the spark-gap decrement.

If, however, we conceive the efficiency as the ratio of the useful energy, radiated at the fundamental oscillation to the total energy supplied to the antenna by charging, the result is even less favorable. In the MARCONI transmitter there necessarily exist at the start not only the fundamental, but also a series of partial oscillations. These are of no use so far as the distance effect is concerned, as the receivers are always tuned to the fundamental oscillation. Hence the energy consumed in one form or another by the upper partial oscillations represents a further loss which causes an additional decrease in the efficiency.

b. From observations made to date, it appears that with a given antenna, the effect of the oscillations and also the distance effect do not increase as the spark length is increased beyond a certain point, in fact, they decrease beyond this point.* Apparently this turning point occurs earlier, according as

1. The effective capacity of the antenna is smaller (hence in this respect a multiple antenna is preferable to a simple antenna);

2. The radius of curvature of the gap electrodes is smaller (hence large spheres or plates are better than small spheres).

c. In *tuned* telegraph operation, the MARCONI transmitter is at a disadvantage on account of the great damping of the oscillations, although this is in part only a factor of strong distance effect. MARCONI transmitters can be constructed with decreased radiation damping [Art. 98] and a total decrement of about 0.1. But the weak distance effect of such a transmitter requires a very high potential if long distances are to be attained in telegraphing. This leads to such insulation difficulties, that the reliability of such transmitters becomes uncertain for regular operation, even though they may have shown good results under first tests.

* It is questionable whether this is due solely to the influence of the changed gap length. Presumably brush discharge and circuit losses played an important part in these experiments.

2. THE BRAUN* TRANSMITTER

104. Nature of the Coupling.—The coupled (BRAUN) transmitter consists of a condenser circuit, the “*excitation circuit*,” as primary and the antenna as secondary circuit. The primary and secondary circuits are tuned so as to be in resonance.

a. The coupling may be purely magnetic, *inductive*, or it may be direct, *conductive* [Art. 52*b*]. The former is shown diagrammatically in Fig. 210, the latter in Figs. 211 and 212. With direct coupling the secondary circuit is comprised of the aerial proper (plus *BA* in Fig. 212), a portion (*BE* in Fig. 211 and *AE* in Fig. 212) of the condenser circuit and the line to ground, or, if a counterpoise is used,

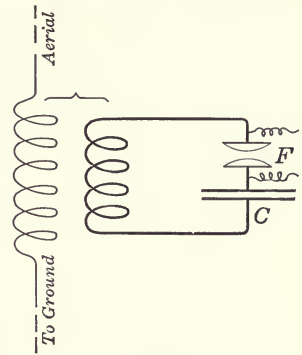

FIG. 210.

this and its leads.

In addition to these, mixed or combined forms of these arrangements have been used or are still partly in use (*e.g.*, Fig. 213).

b. The direct and the inductive connections do not give materially different results. The direct coupling has the advantage of simplicity; above all it avoids the necessity of insulating the primary and secondary turns from each other, which to say

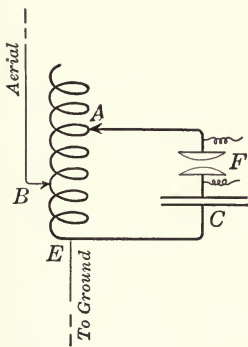

FIG. 211.

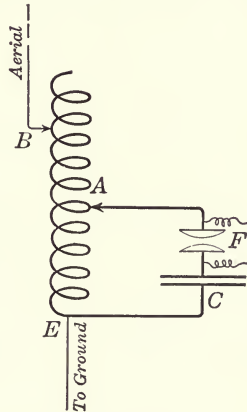

FIG. 212.

the least involves considerable inconvenience for the inductive arrangement. Direct coupling is now in very wide use; the inductive or mixed form is possible only for very close coupling.

105. Coupled Transmitter for Antennæ having High Damping. Very Loose Coupling.—Under highly damped antennæ are to be understood such whose decrement

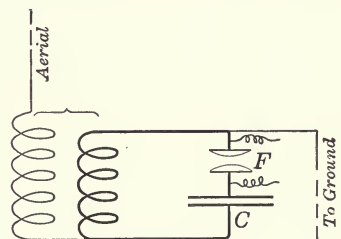

FIG. 213.

* F. BRAUN was probably the first to introduce the coupled transmitter into the practise of radio-telegraphy. His patent is dated in 1898. In the same year E. DUCRETET¹⁶⁴ made some tests in France using an “*Oudin resonator*” (in its essentials arranged like Fig. 212) and thereby already recognized the importance of tuning.

(as that of a simple antenna) is 0.2 or more. Very loose coupling we may define as such that the complications discussed in Art. 58 (two frequencies even with tuned primary and secondary) are not noticeable.*

a. So far as the *frequency* is concerned, the primary and secondary circuits must be *exactly* in tune.

b. The *time change* of the oscillations in the *aerial* is similar to that shown in Fig. 123. Only one oscillation (*i.e.*, one frequency), whose amplitude first increases and then falls off, exists. The looser the coupling, the more nearly *the rate of the decrease or falling off of the amplitude is that which would be obtained with an oscillation having the decrement of the condenser circuit, i.e.*, 0.06 to 0.1.

The *current distribution* along the antenna is the same as for the natural oscillations of the antenna. It may at times be advantageous to so shape the current distribution, by inserting a condenser, as to bring the current anti-node quite high. The fact that this reduces the degree of coupling between the primary and secondary circuits as compared to having the coupling at the point of the anti-node of current [Art. 53b] is not detrimental in this case.

c. Very loose coupling is used when it is essential to produce very slightly damped oscillations. In practice, however, there is always the accompanying requirement that the distance effect should be as great as possible without seriously increasing the damping. Now from Art. 88 it appears that the current effect in the receiver (circuit *III*) at very loose coupling is rapidly increased by making the coupling slightly closer. Hence for good distance effect it is important to make the degree of coupling as high as the sharpness of resonance will permit.

106. Coupled Transmitter for Antennæ having High Damping. Close Coupling.—When the greatest possible distance effect is desired without regard to high damping, close coupling† is in general advantageous because of the increased current amplitude it provides.

a. We then obtain, whether the primary circuit is in tune with the antenna or not, two distinct oscillations of different frequency and hence [Art. 24] different current distribution along the antenna, different current amplitudes at the current anti-node and different decrements. As a matter of fact the primary is probably always tuned to the secondary circuit. Then, from Art. 58, *et. seq.*, we may conclude: the oscillation having the higher frequency (shorter wave-length) has

1. A greater current amplitude at the anti-node of current.
2. More favorable current distribution along the antenna; the cur-

* That is $K^2 < \left(\frac{d_1 - d_2}{2\pi}\right)^2$ [Art. 57].

† That is $K^2 > \left(\frac{d_1 - d_2}{2\pi}\right)^2$ [Art. 58].

rent distribution curve for a simple antenna will be of the form of curve *I*, Fig. 214, for the shorter wave oscillation, but like curve *II* for the longer wave oscillation. With antennæ having increased end capacity the two curves are not much different from each other.

3. A decrement which may be either greater or less than that of the longer wave oscillation, but never much different from it.

Hence the *effect upon a receiver is better*, in fact much better in some respects, *if the receiver is tuned for the oscillation having the higher frequency (shorter wave-length)*.

b. Whether it is best to tune the condenser circuit exactly to the antenna appears questionable according to Art. 89. It is probable that a better effect of the more rapid oscillation upon a receiver is obtained by giving the condenser circuit a frequency slightly higher than that which the antenna had before coupling. The author does not know whether this has been tested in practice. An increase in the effect of more than a few per cent. can, however, hardly be expected, judging from the laboratory results.

c. According to Art. 88 the *current effect* in a receiver (which here corresponds to the measuring circuit) tuned to the higher oscillation, is greatest when the coupling is between 4 per cent. and 10 per cent. However in Art. 88 the tests were made with a condenser circuit as secondary, while in practice we have an open circuit transmitter, whose current distribution must be considered. With antennæ having increased end capacity this can make but little difference, but with others, the current distribution for the more rapid oscillation is improved as the coupling becomes closer. Hence we may conclude that a fairly close coupling is advantageous for antennæ.*

d. The *current amplitude* at the anti-node of current in the antenna, which largely determines the distance effect, is given, for the shorter wave oscillation, by the expression [Art. 61a],

$$I_{2_0}^I = \pi N^I \sqrt{C_1 C_2} \cdot V_{1_0}$$

* Widely varying degrees of coupling have been and still are used in practice. The TELEFUNKEN Co. formerly used up to 10 per cent. coupling, in special cases having obtained excellent results with much higher degrees of coupling. The Eiffel Tower transmitter operates at 4.7 per cent. coupling.⁴⁸ FLEMING¹ states the usual range of coupling to be from 30 per cent. to 70 per cent. Presumably the degree of coupling is of very little importance as long as it is kept over a certain lower limit. It would seem as if the worst effects of very close coupling are compensated by the resulting advantages in other directions.

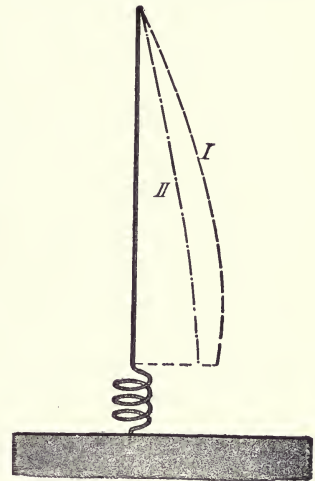

FIG. 214.

Hence, the frequency (wave-length) being given, it is advantageous to use antennæ having large effective capacity. Similarly the primary circuit should have as *large capacity* as possible, compatible with the available energy. A limit to the amount of capacity is encountered in that, with a given frequency, increasing the capacity requires a reduction in the dimensions of the current path, which may make it impossible to obtain a sufficiently high degree of coupling.*

This same reason may at times make inductive or mixed coupling necessary, in such cases where it is impossible to make pure conductive coupling sufficiently close without sacrificing the advantages of large capacity.

107. Coupled Transmitters for Slightly Damped Antennæ.—*a.* The case of *very loose coupling* need not be considered for antennæ whose decrement is less than 0.1; for the object is to produce oscillations in the antenna which have not the high damping corresponding to the natural oscillation of the antenna, but the low damping of the condenser circuit. In the case we are considering, in which the condenser circuit has the same or only slightly lower damping than the antenna, this would have no practical value.

b. The effects of varied degrees of *coupling* are qualitatively the same as for more highly damped antennæ. The tests of Art. 88, conducted with a condenser circuit as the secondary, indicate that 6 per cent. is about the best coupling for the current effect. However, for antennæ whose current distribution varies widely at different points it must be remembered that the closer the coupling is made the more advantageous for good distance effect does the current distribution become. How much this factor tends to displace the best degree of coupling is a question which has probably not been answered to date by actual tests.

Practical experience seems to lead to the conclusion that either the degree of coupling is quite immaterial or its choice depends upon the special conditions of the particular case to such an extent, that no generalizations can be made. The TELEFUNKEN Co. reports excellent results with a 60 per cent. coupling, yet this same company used a 4 per cent. coupling at its Nauen high-power station.

c. As regards the *kind of coupling* it should be pointed out that for umbrella type aerials having very large effective capacity the direct (conductive) connection can be applied even for very close coupling. This can be made clear from a consideration of the equation [Art. 53*b*]

$$K = \sqrt{\frac{L_1^2}{L_1 L_2}}$$

If the entire condenser circuit is used for the coupling and the coupling

* The arrangements which F. BRAUN¹⁶⁵ has devised to meet this condition, under the name of "*Energieschaltungen*" (*i.e.*, "energy connections") obviate this difficulty.

is located at the anti-node of current in the antenna, then L_{1_2} approximately = L_1 and

$$K = \sqrt{\frac{L_1}{L_2}} = \sqrt{\frac{C_2}{C_1}}$$

i.e., the greater the effective capacity, C_2 , of the antenna, the closer will be the coupling.

108. Commercial Form of the Braun Transmitter.—*a. Condensers.*—The requirements of the condensers used are:

1. High breakdown resistance.
2. Small volume, convenient form.
3. Low energy loss due to dielectric hysteresis.
4. No brush discharge.

These requirements are best fulfilled by *air*, particularly *compressed-air condensers*. MARCONI formerly used air condensers at atmospheric pressure at the Clifden and Glace Bay transatlantic stations, which were equipped with a tremendous battery of air condensers totalling 1.6 mf., and which were charged to a potential of about 80,000 volts. Compressed-air condensers of the form shown in Figs. 68 and 69 have been in use by the Nat. Elec. Sign. Co., on the recommendation of FESSENDEN. The disadvantage of air condensers lies in the relatively large dimensions necessitated by the low dielectric constant of air. In this respect condensers of good flint glass are preferable. These are used either in the form of plate condensers, which are submerged in oil to prevent brush discharge (DE FOREST, F. DUCRETET, E. ROGER¹⁶⁶ and apparently also now in use by MARCONI in his transatlantic stations), or else in the form of *Leyden Jars* (the battery of jars shown in Fig. 70 is part of a TELEFUNKEN station of about 500 km. range). The Eiffel Tower station has *Moscicki* condensers [Art. 39b].⁴⁸

In order to minimize the brush discharge the jars are sometimes (*e.g.*, as by the *Nat. El. Sign. Co.*) immersed in oil, or at least they are designed so as to be long and narrow (*Telefunken*) and are arranged in series-parallel combinations. For example, the *Nauen* station formerly had three batteries, each consisting of 120 jars in parallel (each battery having a capacity of about 1.2 mf.), joined in series (Fig. 215).

b. As to the design of the *current path* of the condenser circuit it is hardly possible to make any general statements. Fig. 216 shows a construction of the TELEFUNKEN Co. As formerly used for a station of 1000 km. range, it was made of silver-plated copper tubing, some of the turns being joined in parallel.

In the arrangements illustrated by Figs. 211 and 212, the contacts *A* and *B* are made so as to be movable, allowing a convenient adjustment of the frequency and the coupling. Needless to state, the current path

should be so designed as to avoid eddy currents in the condenser coatings and other metallic conductors as much as possible.



Fig. 215.

c. The *spark gaps* may have either stationary or rotating electrodes. Gaps with *stationary* electrodes should be designed with as large a radius of curvature as possible so as to avoid undue heating. The ring-

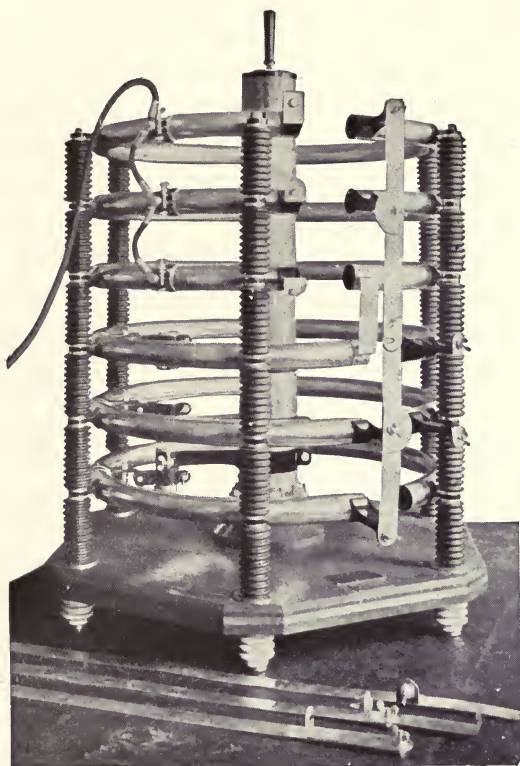

FIG. 216.

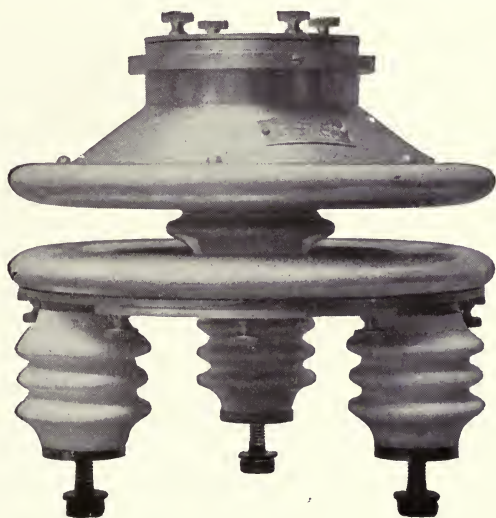

FIG. 217.

shaped electrodes introduced by the TELEFUNKEN Co. (Fig. 217), have apparently been very satisfactory. Frequently the spark gaps are enclosed in a case so as to reduce the terrific noise which accompanies the discharge of very large capacities at high potentials. Enclosing the gap furthermore permits the use of gases other than air and above all makes the use of pressures higher than atmospheric possible.¹⁶⁷

In regard to rotating gaps and the use of air blowers see Art. 118.

3. QUENCHED SPARK-GAP TRANSMITTER. WIEN'S TRANSMITTER

109. Impulse Excitation.—If we understand this term as covering all those methods in which the action in the primary exciting circuit lasts a shorter time than the resulting oscillations in the secondary, we may distinguish between the following kinds of impulse excitation.

a. Attention to one method has already been called in Art. 56b2. If a relatively highly damped primary circuit is caused to act upon a less damped secondary circuit very loosely coupled to it, there will result in the secondary not only an oscillation of the same decrement as that of the primary circuit, but also one having the lower decrement of the secondary circuit. This latter oscillation continues long after the highly damped primary oscillations have disappeared.

This method, at one time, before other methods of impulse excitation were known, was proposed (E. NESPER¹²¹) for use in connection with measurements. It should not come into question, however, in radio-telegraph practice. High damping, *i.e.*, high energy consumption in the primary, in conjunction with loose coupling, *i.e.*, with only a small part of the energy transferred to the secondary circuit, must necessarily greatly reduce the efficiency.

b. The *quenched gap* method is far more satisfactory. Here, after the primary circuit has had the opportunity to give up the most of its energy to the secondary, the oscillations in the primary are quenched. The principle of this method was discussed in Art. 62 *et seq.*, its practical application in Art. 111 *et seq.*

c. Regarding a kind of *mechanical quenching* by means of a *rotating spark gap* see Art. 118b and d.

d. An *impulse excitation in the true sense of the word* is represented in Figs. 218 and 219. If the circuit from the cell *E* is first closed and then abruptly opened by means of the interrupter *A*, the resulting current curve will be about like that marked *I* in Fig. 220. This will produce an e.m.f. of the form of *E* in Fig. 220, in the coil *S*. The current resulting from this e.m.f. charges the condenser, *C*, which discharges in its natural period (G. EICHORN¹⁶⁸). Hence, while with the quenched gap method we have regular *oscillations* in the primary which are quenched fairly rapidly, we have in this case of true impulse excitation, an *aperiodic* action which produces the oscillations in the secondary.

The advantages of this method for measuring purposes have already been pointed out in Art. 78*d*. A good interrupter is of course essential; those having the contact fastened to a stretched string or wire which is vibrated by an electromagnet are well suited to the purpose.*

A practical application of this method is in the form of the so-called

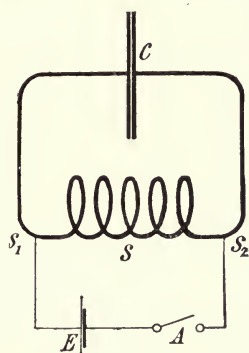

FIG. 218.

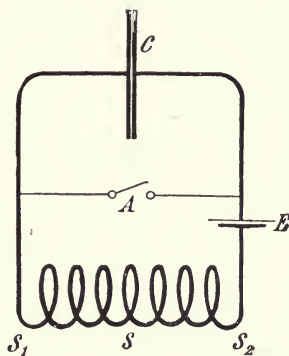

FIG. 219.

“station-testers,” condenser circuits of adjustable frequency, which can be made to oscillate with the aid of very low amplitudes.

Fig. 221 illustrates one of these as made by the TELEFUNKEN CO. The connections are those of Fig. 218. The “make and break” of the direct current is accomplished by an interrupter (at the right of Fig. 221) similar to the ordinary electric bell or buzzer. Frequently wave meters, as for instance that of C. LORENZ and the newer type of the TELEFUNKEN CO., are arranged for use as “station-testers” also.

e. Pure impulse excitation (as described in *d*) or else a condition lying between the cases of the quenched spark gap and pure impulse excitation can also be obtained with a condenser circuit as primary, if its oscillations disappear at the first passage through zero or at least after a very few oscillations. This condition obtains under certain circumstances with hydrogen spark gaps (B. GLATZEL¹⁶⁹) and especially with unsymmetrical gaps,† also to some extent with mercury arc lamps, in fact even when the condenser circuit is not coupled to any secondary circuit. The quenching of the spark therefore is not dependent on the reaction of the secondary.

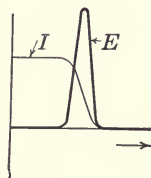

FIG. 220.

*These are made especially for this method by the TELEFUNKEN CO., C. LORENZ and ROB. W. PAUL (New Southgate, London).

†S. EISENSTEIN¹⁷⁰ heated cathode, cold anode; L. E. CHAFFEE—aluminium cathode, copper anode in hydrogen, also at times with gaps having symmetrical electrodes.⁹³

Furthermore, in this case the *occurrence of pure quenching action is of course independent of the degree of coupling*. The latter may be made as high as the arrangement of the circuits permits.

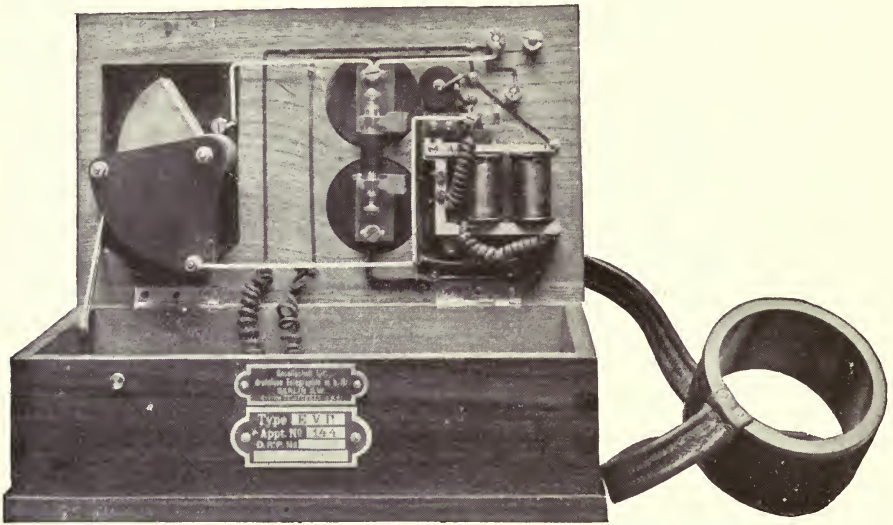

FIG. 221.

E. L. CHAFFEE² has succeeded in obtaining continuous oscillations with such a gap,* in fact even with a frequency of about 3×10^6 per sec. ($\lambda =$ about 100 m.). For this purpose he so regulates his primary circuit and his current supply that after say three cycles of the secondary oscillations there is a discharge of the primary circuit. The first primary discharge excites the secondary oscillations, which fall off slightly during the next two cycles, but are given a new impulse in the third period at the right instant (in phase).

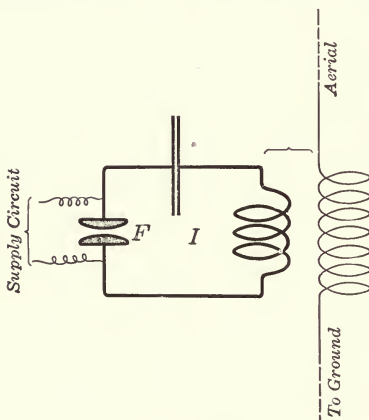

FIG. 222.

110. The Connections.—*a.* These are in general the same for the WIEN transmitter (Fig. 222) as for the BRAUN transmitter. The antenna is coupled either inductively or conductively with

the condenser circuit containing the quenched gap.¹⁷¹

But the *degree of coupling*, while it may be chosen between wide limits

* R. C. GALETTI^{170a} seems to have obtained the same result by means of a peculiar combination of a number of condenser circuits and spark gaps which act successively one after another.

with the BRAUN transmitter, must in the case of the Wien transmitter be adjusted as nearly as possible to the critical degree of the particular spark gap in question in order to obtain the maximum efficiency. For good quenched spark gaps this critical value is usually about 20 per cent.*

In order to obviate the necessity of varying the degree of coupling whenever the wave-length is changed, the TELEFUNKEN Co. has devised the following arrangement (Fig. 223): In the condenser circuit there is placed a coil, L_1 , of much greater self-induction than the rest of the primary circuit. This coil is used for a direct coupling of the antenna.

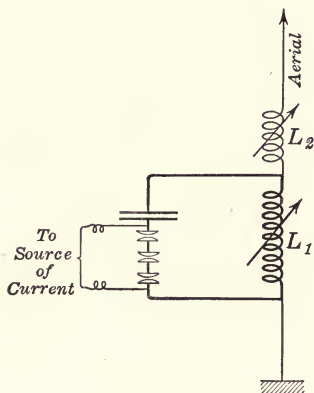

FIG. 223.

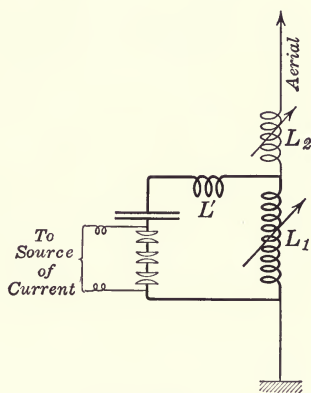

FIG. 224.

The wave-length is changed by varying the coefficient of self-induction of this coil (which in the actual construction is in the form of a *Rendahl* variometer), and the tuning of the antenna to the primary circuit is effected by means of the special tuning coil L_2 .

Under these conditions the coefficient of coupling remains constant and independent of the wave-length. We have

$$K = \sqrt{\frac{Ls_1^2}{L_1L_2}} = \sqrt{\frac{L_1^2}{L_1L_2}} = \sqrt{\frac{L_1}{L_2}} = \sqrt{\frac{C_2}{C_1}}$$

as after tuning C_1L_1 must = C_2L_2 [Arts. 3 and 27].

As a matter of fact, it is advisable to make the coupling somewhat looser for the shorter waves. For this purpose an additional coil, L' (Fig. 224), which is not used for the coupling and whose self-induction is of no consequence for the long waves (L_1 being very large) but comes

* In Art. 64b it was brought out that some quenched gaps have several critical couplings. That one which gives the greatest current effect in the secondary is of course chosen. With the gaps described in Art. 109, the coupling may be increased far above 20 per cent., in fact to 40 per cent. or even higher. So far, however, it has not been demonstrated that this has resulted in higher efficiencies than have been obtained with ordinary quenched gaps.

into importance for the shorter waves (L_1 relatively small), is inserted in the primary circuit.

b. The oscillations sent off into space are virtually the natural oscillations of the antenna. Their damping should be kept as low as possible to secure sharp resonance in the receiver. Accordingly it is universal practice to use antennæ with greatly decreased radiation damping [Art. 98] and make provision for reducing their losses as much as possible in order to maintain a good efficiency for the antenna [Art. 99].

If it were desired to use antennæ with strong radiation and the attendant high radiation damping and yet keep the damping of the oscillations radiated into space fairly low, this could only be accomplished by

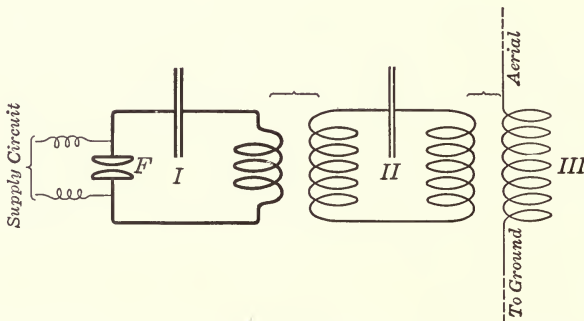

FIG. 225.

means of the arrangement shown in Fig. 225. The primary quenched gap circuit, *I*, is coupled to a very weakly damped condenser circuit (the "intermediate circuit" *II*) which in turn acts inductively upon the antenna through a very loose coupling. The relation between the intermediate circuit, *II*, and the antenna, *III*, is the same as for a loosely coupled BRAUN transmitter [Art. 105], so that the oscillations of the antenna can be made to have the same low damping as the intermediate circuit.

The intermediate circuit, which adds a material complication to the equipment, has been dropped in radio practice.¹⁶⁰ It has been found preferable to secure low damping for the radiated oscillations by reducing the damping of the antenna itself. An intermediate circuit would then be of value only if its decrement were much less than 0.05, say at least 0.01–0.005. This to be sure can be attained in the laboratory, but hardly in practical installations.

111. Practical Construction of Quenched Spark Gaps.—Their short life stands in the way of the commercial use of the mercury arc lamp and the quenching tubes mentioned in Art. 63, unless some more durable form be devised in the future. Such quenched spark gaps as have

found application in practice (some however only for a short time), have all belonged to the class of very short metallic gaps.

Some of these spark gaps—a number of them have been called “high frequency generators”—were believed by their inventors, who worked with a very high spark frequency, to produce undamped oscillations. As a matter of fact, however, under the actual working conditions these gaps all acted as quenched spark gaps.

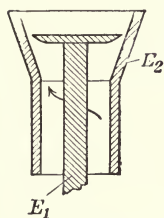

FIG. 226.

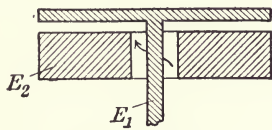

FIG. 227.

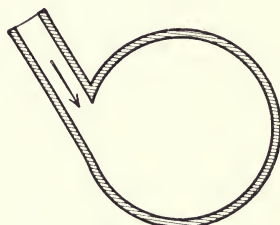

FIG. 228.

a. The gap made by the *Badische Anilin und Sodafabrik* (von KOCH¹⁷²) has two concentric metal electrodes (Figs. 226, 227), very close together, between which a whirling eddy of air is blown.

This eddy is obtained by blowing the air into the cylindrical or conical space between the two electrodes tangentially, as shown diagrammatically for a simple case in Fig. 228. This whirling of the air has the following advantages:

1. Intensive cooling of the electrodes.
2. The spark is blown about all over the electrode so that the discharge is constantly taking place at new spots, not heated by the preceding discharge. Hence we obtain in this way much the same advantages as are obtained with rotating electrodes, viz., regularity of the discharge, increased breakdown potential and thereby increased energy.

3. The spark gap is rapidly deionized, thereby raising the breakdown potential and preventing the formation of arcs.

Ordinary fans or blowers generally are not sufficient for increasing the quenching action (H. RAU⁸⁸); the air velocities obtained, unless very special means are employed, are not great enough to renew the air fully in the short time available for deionization [see Art. 656]. To be sure, the use of extremely powerful blowers makes it possible to materially increase the quenching action and also to obtain quenching in gaps several millimeters long, under conditions which without a blower would give rise to the different coupling waves (B. GLATZEL, PICHON¹⁷³).

b. In the “plate spark gap”¹⁷⁴ devised by E. v. LEPPEL¹⁷⁵ the electrodes

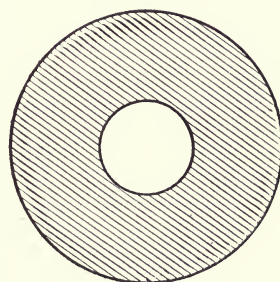

FIG. 229.

are two metallic plates having a very narrow and finely adjustable space between them. They are separated by a paper ring (Fig. 229) made of



FIG. 230.

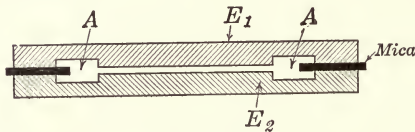

FIG. 231.

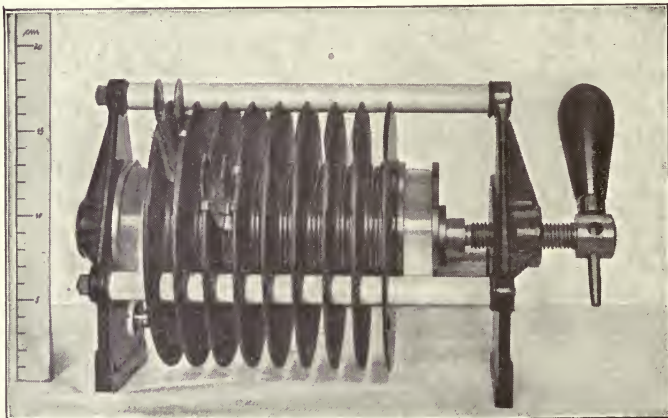

FIG. 232.

carefully chosen material. The spark which passes over the gap in the space left open by the hole in the paper ring, tends to choose points along the edge of the paper, which is gradually burned away by the spark.

Presumably the paper provides against the non-passage or at least the irregular passage of the spark, which would otherwise result with the low

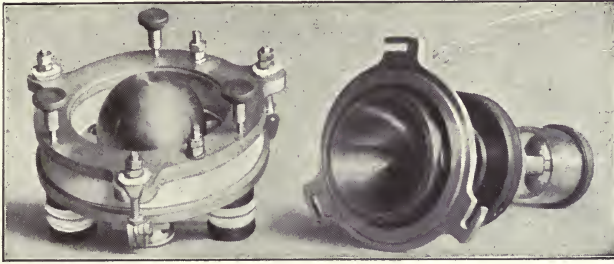

FIG. 233.

potentials (sometimes only 220 volts, D.C.) used by v. LEPEL. Fig. 230 illustrates the exterior construction of one of these gaps as arranged for water cooling.

c. Particular credit is due the TELEFUNKEN Co.¹⁷⁶ for its work in the constructive development of the quenched plate gaps. Its gap, a diagrammatic cross-section of which is shown in Fig. 231, has electrodes of silver-plated copper. Between the rims of these plates is a mica ring which serves both as an insulator and an air seal. The widened space AA, is intended to prevent the spark from discharging at the rim of the mica ring. The distance between the faces of the electrodes is very small, about 0.2 mm.

As only a comparatively very low

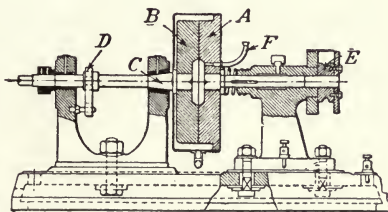

FIG. 234.

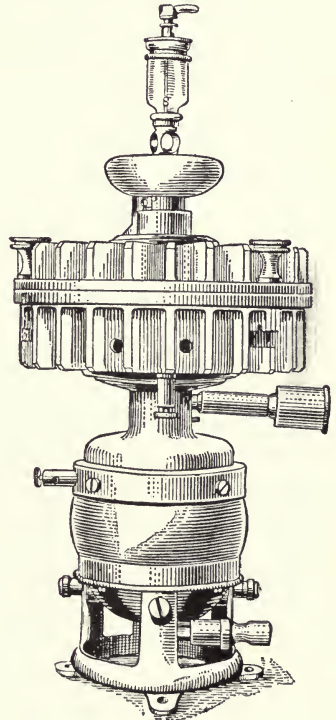

FIG. 235.

voltage, and hence low energy in the individual oscillations, can be applied in view of the shortness of the gap, the TELEFUNKEN Co. always uses a number, say 10 or 12 of the gap elements or sections shown in Fig. 231, joined in series, so as to form "series spark gaps" (Fig. 232).

Excellent results have been obtained with these quenched gaps. Nor is it surprising that this form of gap should offer such advantages. The plate gap probably provides the most favorable conditions of all quenched spark gaps, certainly of all those employing stationary electrodes. As the ions are emitted from the metallic circuit, they always find themselves

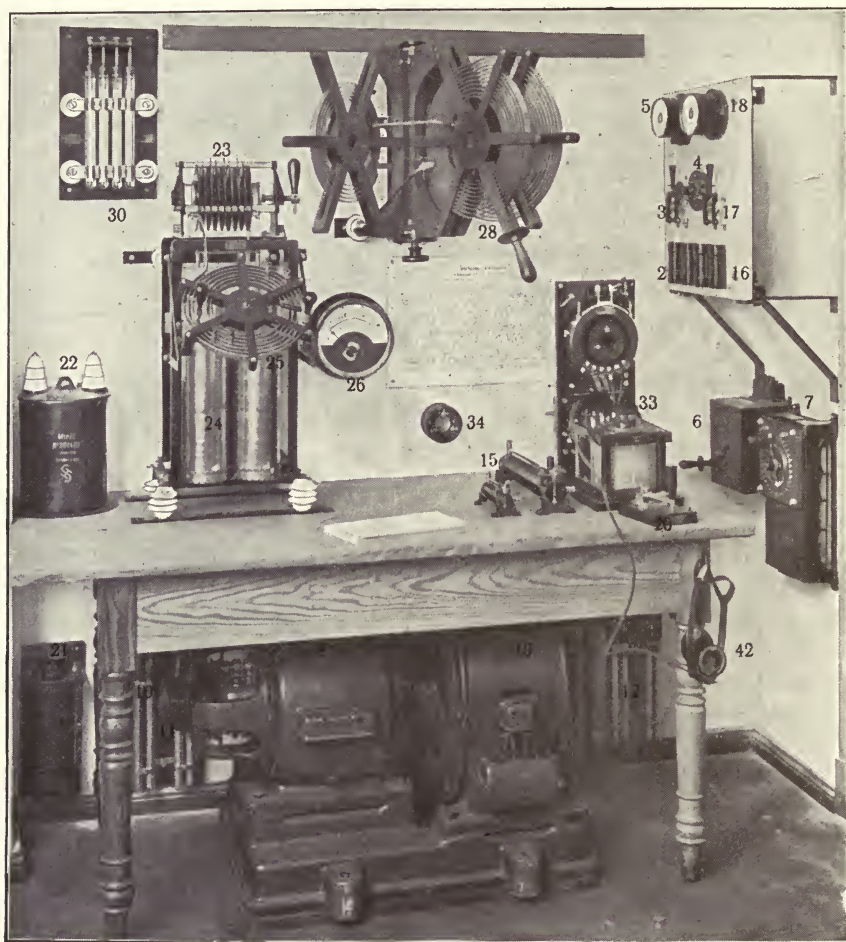

FIG. 236.

in the immediate vicinity of a conducting surface toward which they are driven either by absorption or by the action of the electric field existing between the gaps. Consequently the degree of coupling may be brought as high as say 20 per cent. even with relatively large amounts of energy and thereby a high efficiency can be attained.

These gaps moreover have the great practical advantage of requiring hardly any attention or re-adjustment. The spark moves about over the

surface of the electrode so that the latter is worn down very evenly and very slowly. Hence it need be cleaned only at very long intervals. The

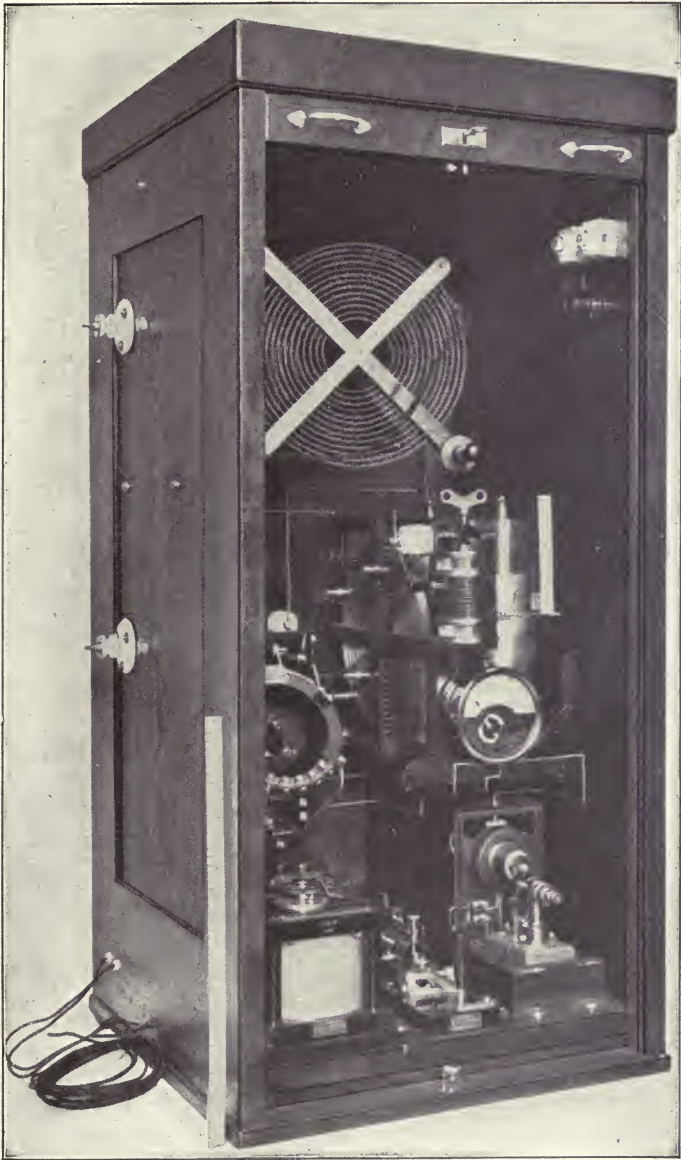

FIG. 237.

series of gaps, moreover, offers a simple and convenient method of varying the radiated energy; to reduce this simply requires the short-circuiting of

one or more of the individual gaps—as may be necessary, for instance, when suddenly called upon to work with a much nearer receiving station.

d. The gap made by C. LORENZ (O. SCHELLER¹⁷⁷) (Fig. 233) instead of having flat plates, consists of two concentric or almost concentric spherical surfaces. In this construction the gap length is practically the same at all points.

e. The gap devised by W. PEUCKERT¹⁷⁸ also belongs to the plate-gap class, differing from the others in that at least one of the two electrodes is rotated.

Two forms of this gap are shown in Figs. 234 and 235. In the former the plates, *A* and *B*, are vertical. One of these, *A*, is stationary, and through this oil is kept flowing, which then spreads out in the space between the two plates. In the second form (Fig. 235) the plates are in a horizontal plane. An atmosphere containing hydrogen between the plates is procured by allowing alcohol to drip from a holder on top into the gap. The *Peuckert* gap, which for a short time was made by the so-called Polyfrequenz-Elektrizitätsgesellschaft, is distinguished by great regularity of the oscillations.

112. Commercial Construction of the Wien Transmitter.—*a.* Figs. 236, 237 and 238 illustrate three quenched spark-gap stations of the Telefunken Co.¹⁷⁹ The explanation* given below for Fig. 236 is probably

- * 2. = 40 amp. D.C. fuses.
- 3. = D.C. switch.
- 4. = Voltmeter switch.
- 5. = Voltmeter—250 volts.
- 6. = Motor starter.
- 7. = Field rheostat (motor).
- 8. = 4 HP, 110 volts, 1500 r.p.m., D.C. motor.
- 10. } = High frequency protective devices (condensers).
- 11. }
- 12. }
- 13. = 2 kw., 250 volts, 500 cycles. Alternator.
- 15. = Slide rheostat for alternator field.
- 16. = 30 amp. A.C. fuses.
- 17. = A.C. switch.
- 18. = A.C. ammeter, 50 amp.
- 20. = Key.
- 21. = Choke coil for main supply circuit.
- 22. = 220/8000 volts transformer.
- 23. = Quenched spark gap—8 sections.
- 24. = Primary capacity 27×10^{-3} MF.
- 25. = Primary self-induction.
- 26. = Aerial hot-wire ammeter, 20 amp.
- 28. = Aerial variometer.
- 30. = Antenna shortening capacity.
- 33. = Receiver.
- 34. = Primary transformer coil of receiver.
- 42. = Telephone.

sufficient for an understanding of the other two figures. The simplicity of these stations is at once evident. One need only compare Fig. 238,



FIG. 238.

illustrating the quenched gap transmitter of the Nauen high-power station with the former BRAUN transmitter (Fig. 215) of the same station to appre-

ciate this. This simplicity of quenched gap sets is made possible by the comparatively low potentials, *e.g.*, 8000 volts in the 2 kw. station shown in Fig. 236, which can be used; this removes the necessity of connecting the condensers in series. In fact the use of the extremely convenient mica or paper condensers has become possible. The one disadvantage of these last-named condensers, namely, their high energy dissipation, does not come into question so much here as it does in the case of the BRAUN transmitter. For, as the oscillations of the primary circuit are quenched after the first few cycles, it is not so serious that the condensers consume somewhat more energy per cycle, particularly as this loss is very small in comparison to that in the gap. Nevertheless, as long as there are no special limitations to the space available, good Leyden jars, air or oil condensers are always given preference in order to keep the efficiency as high as possible; and this can usually be done, as the moderate potential makes it possible to keep the dimensions of such condensers comparatively small.

b. The circuit connections have already been discussed in Art. 110; they are probably as shown in Fig. 224 in most cases. When changing of the wave-length between wide limits is desired, this is frequently obtained by inserting a condenser (the small battery of Leyden jars marked 30, in Fig. 236) directly in the antenna for the shorter waves and connecting it in parallel to an inductive coil in the antenna for the longer waves [Art. 98c].

4. GENERAL CONSIDERATION OF TRANSMITTERS OF DAMPED OSCILLATIONS

113. Operation by Means of Interrupted Direct Current.—The use of *spark coils (induction coils) operated by interrupted direct current* is quite frequent in small stations.



FIG. 239.

The *induction coil* must be able to give a relatively large amount of electricity at moderate potential rather than very high potential. The requirements are therefore quite different from those for the operation of X-ray (ROENTGEN) tubes.

The usual *electromagnetic interrupter* suffices for small currents. It is economical of both room and energy, and hence continues to be used for small portable sets and airships, and also for quenched gap transmitters on shipboard as shown in Fig. 237 (particularly in the form of emergency equipment, operated from a storage battery), in which

case however a higher frequency of the interruptions is required.

For larger currents the *mercury turbine interrupters* have given good

service. Fig. 239 shows one of these as made by the Allgemeine Elektrizitätsgesellschaft. The advantages of the mercury turbine interrupter, particularly for use in measurements, are: 1. It interrupts relatively large currents with great regularity; 2. the speed of the motor and hence the frequency of the interruptions are independent of the amount of current to be broken.

114. Alternating-Current Operation.—The disadvantage of induction coils with interrupted direct current lies mainly in the difficulty of obtaining sufficient quantities of electricity to charge *large* condensers to a high potential. The use of alternating-current and commercial transformer designs at once suggests itself. A.C. operation differs according to whether

1. Ordinary spark gaps (BRAUN transmitter) or
 2. Quenched spark gaps (WIEN transmitter)
- are used.

a. In the first case (BRAUN), where in general very high potentials are used, if we were simply to connect the primary (low-tension side) of the transformer to the generator and the secondary (high-tension side) across the spark gap, the following difficulties would result:

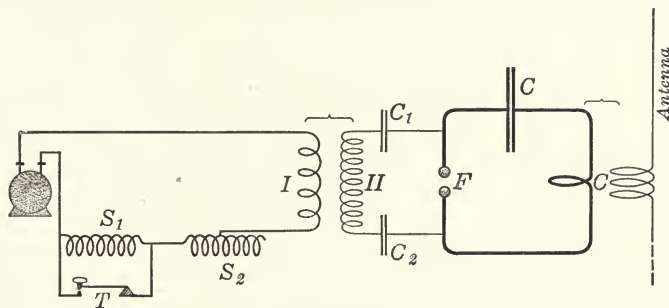

FIG. 240.

1. The A.C. transformer would continue to deliver current after the oscillations in the primary circuit had died out. That leads to the formation of arcs, which heat the electrodes, ionize the gap for an unnecessarily long time, thereby lowering the breakdown potential and the initial amplitude of the oscillations.

2. The high-tension side of the transformer is almost short-circuited by the spark. This may damage the winding and also cause a disadvantageous reaction upon the primary of the transformer (low-tension side).

This second difficulty can be overcome, at least in part, by inserting condensers (C_1C_2 Fig. 240)* or choke coils in the leads from the trans-

* The connections shown in Fig. 240 are those formerly used in the Marconi Station at Poldhu.

former secondary to the spark gap, also by placing sufficiently large choke coils in the primary side (S_2 , Fig. 240) of the transformer.

As to the first-named difficulty, much depends upon whether a very high discharge frequency—*e.g.*, 500 to 2000 per second for “**tone transmitters**”—or a low frequency, say 5 to 25 per second, is used. With the

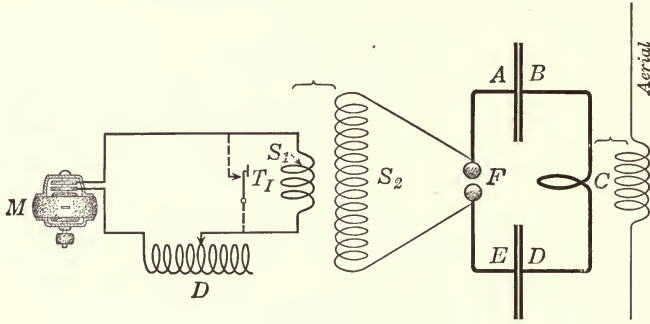

FIG. 241.

higher frequencies, the use of *rotating spark gaps* [see Art. 118b] is probably not feasible, if the energy handled is large.

With the low frequencies, the various operating difficulties can be very ingeniously overcome by the arrangement⁹⁸ employed by the TELEFUNKEN Co. under the name of “**resonance inductor**” or “**resonance transformer.**”

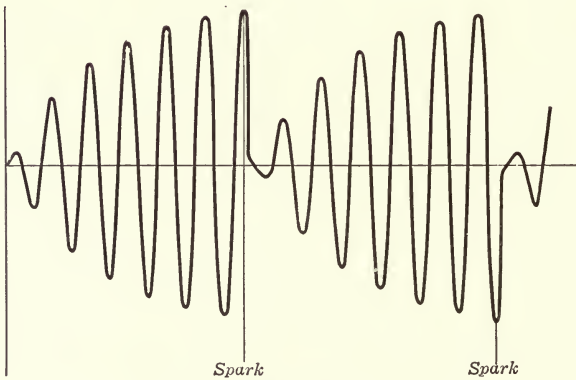

FIG. 242.

The transformer (or induction coil) has an open core; its terminals are connected to the condenser circuit in the usual manner (Fig. 241). The spark gap, E , is so adjusted in length that the normal secondary potential is far below that necessary to jump across the gap. We then have the case discussed in Arts. 67 and 68: an undamped oscillating primary circuit (armature of the alternator, coil D , and primary coil, S_1 , of the

resonance transformer) coupled to a condenser circuit (secondary coil, S_2 , of the resonance transformer and $ABCDE$). If these two circuits are adjusted so as to be in resonance, then the oscillations which result upon completing the primary current path, will be about as shown in Fig. 242. The current amplitude and hence also the potential amplitude increase with each cycle, the potential rising far above the normal value which would correspond to the ratio of the transformer, until, after a number of periods, a spark jumps across the gap, F , thereby causing the condenser circuit $FABCDEF$ to oscillate rapidly.

Due to these oscillations, the energy which has been accumulated in the condenser circuit S_2ABCDE , is quickly consumed. Consequently there is a rapid fall in potential, no arc is formed and there is no great increase in the primary current.

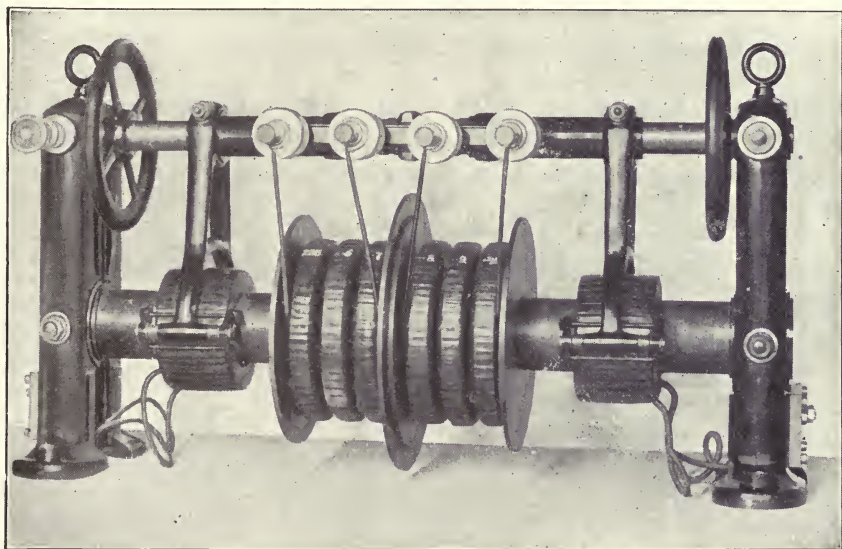

FIG. 243.

This series of events then repeats itself, beginning with the next period. No spark occurs until, after a number of cycles, sufficient energy has been pumped [Art. 61c] into the secondary circuit (S_2ABCDE) to bring the potential to the necessary amplitude.

The advantages of this method are, therefore: avoiding of arcs and of short-circuiting of the secondary coil, low spark frequency and much higher voltage than would correspond to the transformer ratio.*

* With an initial frequency of fifty cycles per second the spark frequency, if so desired, can easily be reduced to five per second and the secondary potential raised to three times the normal transformation value.

For a given transformer and at a given frequency there is a *best degree of coupling*. In order that this may be secured, it is advisable to introduce adjustable inductive coils (*D*, Fig. 241) in the primary (or secondary) circuit or to use a BOAS resonance transformer (Fig. 243)* so as to allow variation of the coupling between the primary and secondary circuits.

In the Telefunken Station at Nauen (Fig. 215) which formerly was operated with a resonance transformer, the high potential was obtained by means of four transformers in parallel (right front of Fig. 215). Two inductive coils (left front of Fig. 215) were placed in the primary circuit.

b. With *quenched spark gaps* (WIEN transmitter) the deionization of the gap [Art. 65] is so intense that the danger of the formation of arcs is far less than with ordinary gaps. Hence with quenched gaps there is nothing to prevent the use of A.C. generators and transformers, nor of machines for *tone* transmission, whose frequency is between 250 and 1000 cycles per second.

It is advisable to so regulate the current that at most two or three partial discharges, preferably only *one* takes place during each half period.¹⁷⁶ With several partial discharges the tone in the receiving telephone [Art. 165] is apt to lose all its purity. And while a flute-like tone free from upper harmonics has no special advantage (in fact a tone having some pure upper harmonics seems to be better for receiving¹⁸⁰), an impure discordant tone, as produced by numerous irregular partial discharges is certainly not favorable for good results. Moreover such irregular, partial discharges tend to weaken rather than strengthen the effect upon the telephone diaphragm, as it may often not have time to return to its position of equilibrium and in any case is forced into extremely complex movements.

If the current is further weakened, the same effect as is obtained with a resonance transformer can be secured, a spark passing only every second or third half period; the tone heard in the receiver is then at the correspondingly lower octaves.

c. One danger to which the alternator, and, under certain conditions, also the motor driving it are subjected, consists in the high frequency currents induced in the leads by the primary circuit or antenna currents. These may produce very high potentials endangering the insulation. To counteract this as much as possible it is customary to connect condensers (those marked 10, 11, 12 in Fig. 236) or sometimes non-inductive resistances (incandescent lamps) in parallel with the motor and generator.

115. Direct-current Operation.—*a.* Direct current at high potential may also be used in the supply circuit for charging the condensers, especially when quenched spark gaps are used. The arrangement for these conditions is very simple (Fig. 244). The quenched gap circuit, *I*, is connected to the D.C. generator through series resistance, *R*₀, and induc-

* These are particularly recommended for measuring purposes.

tance, L_0 . If the voltage, the gap length and the supply current are properly adjusted with respect to one another, instead of an arc resulting across the gap electrodes we obtain a varying potential like that illustrated in Fig. 291 (lower part). The direct current charges the condensers and their potential rises until the breakdown potential of the gap, F , is reached. Then the potential falls through a series of oscillations reaching zero or almost zero, whereupon the process repeats itself. The number of discharges per unit of time depends upon the size of the supply current, as this determines the time necessary for bringing the condensers to the breakdown voltage of the gap. The discharge frequency can accordingly

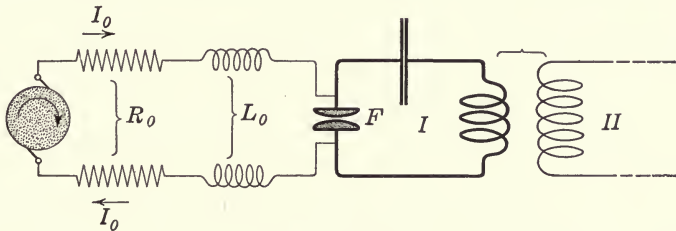

FIG. 244.

be varied between wide limits by regulation of the current supply. In order to secure regularity of the discharges, it is important to bring the voltage up as high as possible, at any rate not lower than 1000 volts.

The *series resistance* in the supply circuit should preferably have a rapidly rising characteristic. The *Nernst* resistances, consisting of iron wires in a glass bulb filled with hydrogen, are particularly well suited to this purpose; metal filament lamps may also be used.

b. The inductance, L_0 , should be wound without iron; if for any reason an iron core is desired, it is advisable to keep the magnetization above the saturation point.

The effects of the self-inductance are as follows:¹⁸¹

1. It greatly reduces the fluctuations of the supply current.
2. The maximum gap potential is greatly increased by the inductance, at times even rising considerably above the dynamo potential.*
3. The increased maximum potential improves the irregularity of the discharges and, finally,
4. The series resistance, and hence the energy consumed in the supply circuit, can be less than would be required without the self-inductance, without endangering the generator.

c. The supply source is usually a *D.C. generator* several of these being connected in series if necessary. In the Marconi transatlantic stations

* In the transatlantic Marconi stations (Fig. 255), the actual maximum gap potential, with 12,000 volts normal generated (storage battery) potential, is stated to be about 18,000 volts.¹⁹¹ This is apt to be dangerous for the generator. See Art. 114c for methods of protection against this.

at *Clifden and Glace Bay*, a storage battery of 6000 cells, corresponding to a potential of about 12,000 volts (see Fig. 255), is in parallel with the dynamos or can also be used alone.

116. Measurement of the Energy Supplied; Determination of the Efficiency.—To measure the efficiency of a radio transmitter, it is necessary to find the energy used in the secondary circuit on the one hand and that supplied by the current source to the primary circuit on the other.

a. Measurement of Energy Consumed in the Secondary Circuit.—If the kind of secondary circuit is optional, it is advisable to choose a condenser circuit and to determine its effective resistance, R , by measuring the decrement [Art. 77, *et seq.*]. It may be well to construct the current path of braided conductors having individually insulated wires and to insert in this a resistance, R , of very fine constantan wire (special resistance material) which has the same resistance for oscillating as for direct currents [see Art. 36*b*] and which should be so large that the resistance of the rest of the current path becomes negligible in comparison. If a hot-wire ammeter is then inserted in the secondary circuit and $I_2^2{}_{eff}$ is measured, then $RI_2^2{}_{eff}$ is very nearly equal to the energy consumed per second in the secondary circuit. If the indications of the hot-wire meter are not considered reliable, the resistance can be placed in an insulated (against heat) vessel, filled, say, with oil and the heat developed measured calorimetrically,⁷¹ from which the energy consumption per second in the secondary circuit may be determined.

If the secondary circuit is an antenna, the current effect, $I_2^2{}_{eff}$, is measured by means of an ammeter inserted in the antenna and the resistance, R , of the antenna is measured by one of the methods given in Art. 100*b*. Then the product $RI_2^2{}_{eff}$ = the energy consumed per second in the antenna.

b. Measurement of the Energy Supplied.

1. In the case of *low discharge frequency*, as, *e.g.*, with a Braun transmitter when operated by an influence machine, an induction coil with D.C. interrupter or a resonance transformer, the amount of energy supplied is found as follows: if V = the discharge potential and C = the capacity of the condenser, then the energy in the condenser at the instant just previous to its discharge is $\frac{1}{2} CV^2$. If now there are ζ discharges per second, it follows that the energy which the condenser receives from the supply circuit in each second must be $\zeta \cdot \frac{1}{2} CV^2$.* The discharge voltage, for slow (static) charging of the condensers, can be determined by means of a suitable electrometer,¹⁸² or from Table VI if the spark-gap electrodes are spherical. This, however, applies only if the discharge potential is the same with a static charge as under operating conditions; this condition

* The assumption is that the condenser actually gives up its entire charge. If the condenser coatings after the discharge still retain a difference in potential, V_1 (residual charge), then the energy supplied per second is $\zeta \cdot \frac{1}{2} C(V^2 - V_1^2)$.

can be approximated by projecting ultra-violet light upon the gap electrodes and using a *very* low spark frequency.

2. With a *high* discharge frequency it can not be assumed in general that the discharge potential is the same as the breakdown potential acquired by means of a static charge. In this case, if the discharge potential is not too high, the energy supplied to the primary circuit can be measured by an electrodynamic wattmeter connected either at the point W or W' (Fig. 245), according to whether or not the energy consumed in the series resistances and inductances is to be included.

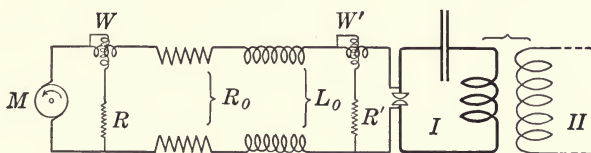

FIG. 245.

As the frequency of the supply current is usually much higher than that of commercial alternating currents and as its form is far from being sinusoidal, the ordinary commercial wattmeters are not to be recommended for this purpose. They generally possess phase errors which, at the lower commercial frequencies, approximately sinusoidal currents and not too great a phase displacement between current and voltage, can be roughly corrected for by means of compensating coils of some sort, but which otherwise may become quite considerable. Hence, we are limited to the use of special wattmeters¹⁸³ in which such errors are carefully avoided, unless it is preferred to use a laboratory wattmeter, consisting of a fixed current coil in which is suspended a potential coil, very small compared to the current coil, made of very fine wire and carrying a small mirror attached to it. The suspension and current lead are best made of a bronze strip, while a telescope and scale serve for reading the deflection. The usual commercial wattmeter multipliers (series resistances are not suitable, as they are not free from capacity and self-induction; incandescent lamps* or liquid resistances† may be used.

3. Another method is based upon the use of the *quadrant electrometer*. A known resistance, R (Fig. 246) which must have practically no inductance or capacity and be independent of the frequency (*e.g.*, a straight, thin constantan wire, placed in a quartz tube filled with oil for cooling) is inserted in the supply circuit, and across its ends, P and Q , the two quad-

* But they must be used *far* below the point of incandescence.

† *e.g.*, the special boracic acid—mannite resistances of MAGNANINI, with platinum electrodes as large as possible. Formula: 1500 g. water, 181 g. mannite, 62 g. boracic acid; to this add a little potassium chloride, the quantity being such as to give the resistance a very slight temperature coefficient.

rant pairs, aa' and bb' of the electrometer are connected. The needle is joined to T (Fig. 246).

Then the theory¹⁸⁴ will show that the deflection of the needle,

$$\vartheta = aR \left[A + \frac{I_{eff}^2 \cdot R}{2} \right]$$

The proportionality factor, a , of the instrument having been determined by calibration with static potentials and the current effect I_{eff}^2 by an ammeter I connected in the circuit, then from the deflection, ϑ , we

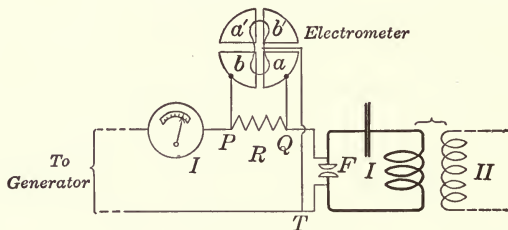

FIG. 246.

obtain the energy consumption per second between the points Q and T , and hence the energy supplied per second to the condenser circuit I .

117. The Key.—*a.* Just as in ordinary wire telegraphy, keys are used for telegraphing. In radio work, however, the difficulty of breaking circuits carrying heavy currents and having high self-induction presents itself. This may at times give rise to large sparks, which rapidly destroy the key contacts.

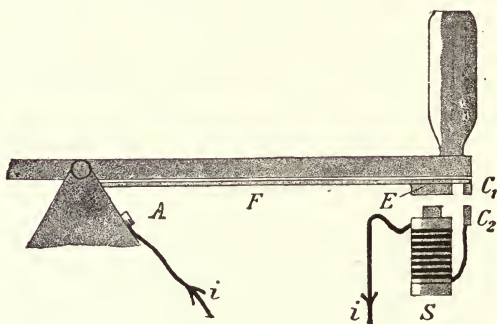

FIG. 247.

These sparks can be reduced by not entirely breaking the current path. This, for instance, is done in the arrangement of Fig. 240 in which closing the key short-circuits the inductive coil, S_1 , and opening the key again causes the full current to flow through S_1 ; in short the current is alternately increased and decreased, but never entirely broken. This method can be reversed by leaving the inductance, in circuit (Fig. 241) and short-circuiting the primary side of the transformer with each closing of the key.¹⁸⁵

A simple solution of the difficulty for moderately large currents is the construction (shown diagrammatically in Fig. 247) formerly used by the TELEFUNKEN Co. and the MARCONI Co., as designed by F. BRAUN and A. GRAY, respectively.*

Underneath the key proper (*i.e.*, the lever arm of the key) a spring, F , is placed, to which an iron armature, E , and a platinum contact, C_1 , are attached. If the key and hence the spring, F , are pressed down, contact C_1 touches contact C_2 and the path of the primary current of the induction coil or transformer, as the case may be, is completed. The current passes not merely through the key, along the route AFC_1C_2 , but then also flows through the winding S . If now the key is released so as to move upward, contact C_1 will nevertheless remain touching C_2 , as the magnetic action due to the current in S continues to hold down the armature E and hence the spring with the contact C_1 . Not before the primary current has become reduced to virtually zero, is the armature and hence the contact C_1 released from C_2 , at which time of course *no spark* is formed.

b. In large stations "*key relays*" are probably always used. An ordinary key, manipulated by hand, closes an auxiliary circuit which (similarly to the remote control switches used for commercial high-tension work) operates the key or contactor opening the main circuit. The construction of good key relays, or "*relay keys*," as they are sometimes called, is by no means a simple matter, owing to the very rapid and frequent interruption of heavy current demanded in telegraph service.

c. Where extremely rapid operation is required, as, *e.g.*, in the Wheatstone rapid method, *automatic keys* can be used.

The principle of these is essentially as follows: The message is punched in telegraph code into a strip or tape of strong paper or other insulating material. For instance, the letter *a* would appear as in Fig. 248. The strip so formed is then pulled between the contacts of a key suitably designed, thereby completing the circuit as each perforation passes through the key. The actual construction of such rapid telegraph apparatus and automatic keys is usually very complicated.¹⁸⁶



FIG. 248.

118. Spark Gaps with Rotating Electrodes.—*a.* In gaps having *smooth electrodes*, as in the MARCONI gap shown in Fig. 249, the spark, which always chooses the shortest or approximately shortest path through the air, will constantly jump across from different points of the electrodes, B , A and B' .† This prevents harmful local heating of the electrodes, which heating, with fixed electrodes, tends to reduce the breakdown voltage of the gap and causes a rapid deterioration of the electrodes

* These designs of the key also prevent the formation of very high potentials at the sudden breaking of the current.

† A is a very rapidly revolving disc, while B and B' rotate slowly.

and consequent irregularities in the oscillations. Furthermore, the air currents caused by the rotation assist the deionization of the spark gap and the cooling of the electrodes. In the spark gaps of F. DUCRETET and E. ROGER¹⁸⁸ (Fig. 250) which have a tube, *C*, as one electrode and a rotating sphere, *S*, as the other, a special strong air current is provided by the ventilator or blower, *V*. The advantage of such provisions becomes more evident as the spark frequency and the current are increased, *i.e.*, as the tendency to form arcs increases.

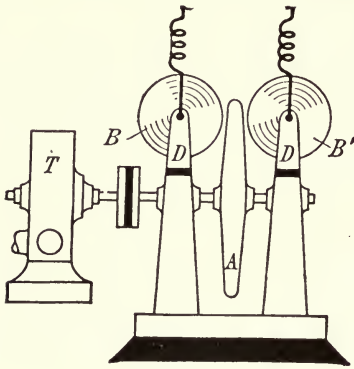

FIG. 249.

252 (MARCONI Co.¹⁸⁹) depends largely upon the shortest distance between the electrodes, their width and their velocity. Let us first assume that the minimum distance between the electrodes is such that

b. The action of spark gaps having small *projections* on the electrodes as, *e.g.*, that shown in Fig. 251 (R. FESSENDEN, NAT. ELEC. SIG. Co.) or in Fig.

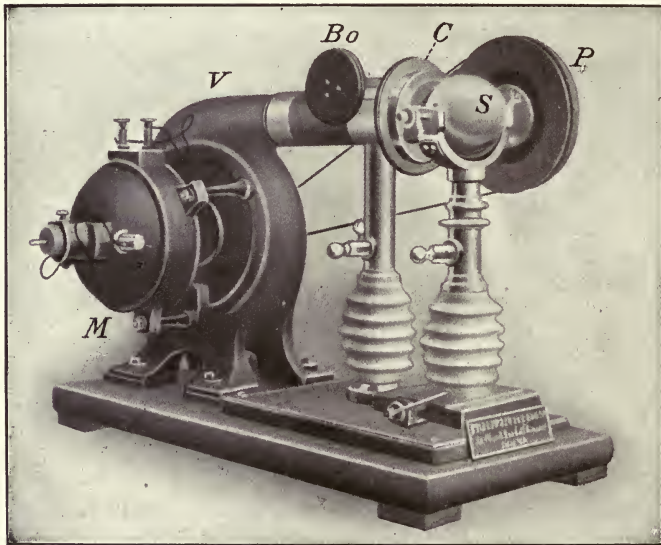

FIG. 250.

the highest potential occurring across the gap will be just sufficient to create a spark discharge. Then

1. With *moderate speed* and *moderate width* of the electrodes, the gap will have the advantage, for A.C. operation, of good cooling of the electrodes and the prevention of arcs, for the gap length grows so rapidly

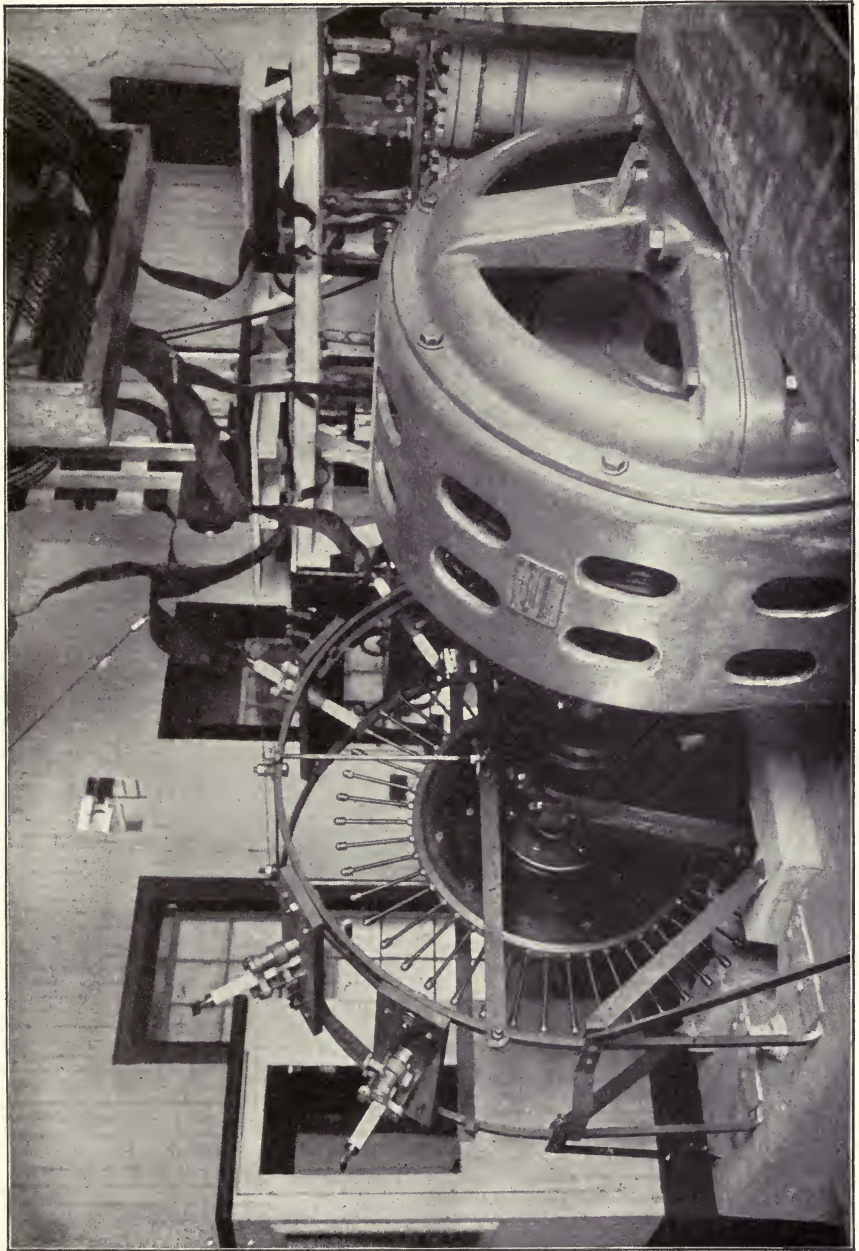

Fig. 251.

after the oscillations have died out that there is no opportunity for an arc formation. In this case then, the spark gap is mounted directly on the shaft of the alternator (Fig. 251) or of a synchronous motor and the number and location of the projections or sparking points so chosen that they are nearest together (minimum gap length) at the instant when the A.C. voltage is at its maximum.

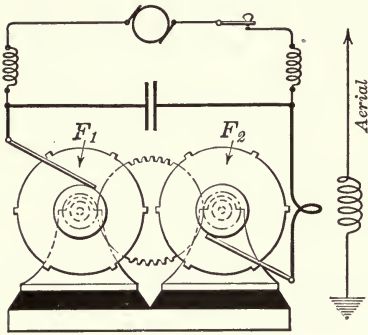

FIG. 252.

With D.C. operation a gap of this type secures regularity of the discharges, the frequency being regulated by the speed control of the driving motor. If this frequency is high enough an audible sound or tone (*tone transmitter*) is obtained in the receiving telephone.

2. If the electrodes are *very narrow* and their *speed very high*, the result may be as follows: The oscillations of the condenser circuit commence at just about the instant when the electrodes are closest together. While the oscillations continue, the gap length increases very rapidly. At the same time the potential amplitude in the condenser circuit, if coupled at all closely to a secondary circuit, rapidly falls off [Art. 59c]. The effect of both these factors, *i.e.*, increasing gap length and decreasing potential,

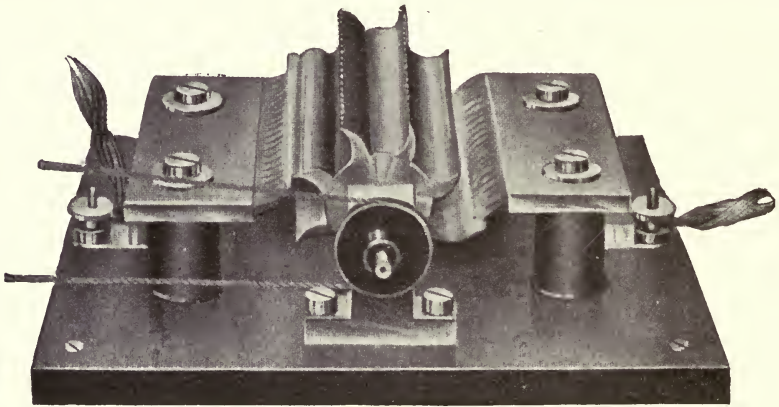

FIG 253.

may be to disrupt the spark after a very few periods, even in such cases where, if the electrodes remained stationary, the spark would not be automatically quenched after half a cycle. (This is sometimes referred to as "**mechanical quenching.**")

Whether or not a mechanical quenching results, depends largely upon the velocity, the wave-length and the *coupling* [Art. 59c] used. If the

peripheral velocity of the electrodes is taken at 200 m. per second (a speed which is obtainable [see *d*]), and a 5 per cent. coupling employed so that the potential amplitude in the primary circuit will be zero or nearly zero after ten periods of the oscillations, then the movable electrode will in this time have covered a distance of 2 cm. with a wave-length of 3000 m., and a distance of 4.4 cm. with a wave-length of 6700 m.* If the gap is properly constructed, however, the distance between the

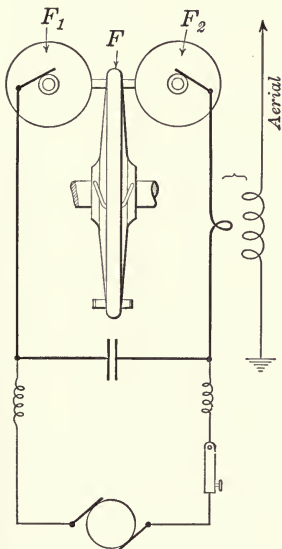

FIG. 254.

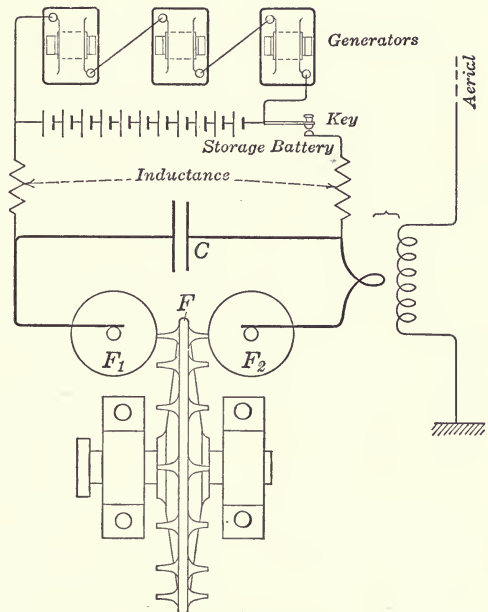

FIG. 255.

electrodes will have become so large by that time that there is very little chance for the spark to form again during the next few periods, particularly if the minimum gap length is very small.

In all cases the effect of increasing the gap length is assisted by the strong air currents formed. In order to fully take advantage of this, spark gaps with rotating electrodes have been constructed in the form of actual ventilators (Fig. 253, *Balsillie System*¹⁹⁰).

c. Another possible case consists in having the gap length less than the length which the potential used can just jump across (Fig. 254, "**short-circuit spark gap**") and to revolve the electrode projections at *very high* speed. When a projection of the rapidly rotating electrode, *F*, approaching the stationary or slowly rotating electrodes *F*₁ and *F*₂, comes sufficiently close, a discharge takes place. While this discharge is occurring the electrodes come nearer together and the gap length, the

* MARCONI'S transatlantic stations [*d*].

gap resistance and the energy consumption are reduced to very low values [Art. 11*d*]. Such spark gaps combine the two advantages of comparatively high initial voltage with a relatively short average gap length and a very short gap length at the time when the oscillations of the discharge have already become very low in amplitude. The best results are obtained, other things being equal, with the highest speeds and, for a given speed, with the greatest retardation of the discharge [Art. 42*b*]. Accordingly ultra-violet light is to be avoided as much as possible.

d. The spark gap shown in Fig. 255, which is used in the transatlantic MARCONI stations at Clifden and Glace Bay,¹⁹¹ is a *combination of a short-circuit gap and a mechanically quenched gap*. The electrode projections on the wheel *F* are so shaped that the gap between the discs *F*₁ and *F*₂ is very small only while there is a projection between the two discs. On the other hand, the peripheral velocity of *F* is so great (about 200 m. per second), the degree of coupling so low—it is reported as being approximately 5 per cent.—and the width of the projections is so measured, that the spark is *disrupted* after half a cycle and does not again form until the next projection comes into play.

The discharge retardation seems to be used to excellent advantage in these gaps; at a potential of 15,000 volts and a frequency of 45,000 cycles per sec. ($\lambda = 6700$ m.) it is claimed that the spark occurs only about *one period* before the instant at which the projections of *F* are at their minimum distance from the discs *F*₁ and *F*₂. The result of this short spark gap combined with the heavy current due to the relatively high discharge voltage and capacity, is a very low energy consumption in the primary condenser circuit. The total decrement of the primary circuit, when not coupled to the secondary, is claimed to be only about 0.03 to 0.06.*

5. COMPARISON OF THE DIFFERENT TYPES OF TRANSMITTERS

119. Difference between the Coupled and the Simple (MARCONI) Transmitter.—*a.* That the coupled transmitters are more complicated and that it costs more to construct them is self-evident. In addition, a relatively small induction coil with mechanical interrupter and a few storage battery cells usually suffices for a simple transmitter with its low capacity; the operating costs are therefore exceedingly low. Hence, if only comparatively short distances† are to be covered in telegraphing and if it is important to keep the energy consumption‡ as low as possible,

* The equivalent resistance of the entire condenser circuit with its spark gap is given in one case as 0.022 ohm.

† Ranges of 100–150 km., with masts about 30 m. high have been attained, with the simple MARCONI transmitter.

‡ *e.g.*, stations which are difficult of access or light portable sets (such as light-ship stations or portable military stations).

the simple MARCONI transmitter offers great advantages, which in fact have caused it to be retained in use to the present day and which will perhaps keep it in use for quite some time to come as an emergency transmitter.

b. But it is in relation to the question of energy that the simple MARCONI transmitter is at its greatest disadvantage. To be sure, it does not require much energy, but the only way in which the energy can be increased is by raising the initial voltage (see *e*). On the other hand, it is possible to radiate much greater quantities of energy in the form of electromagnetic waves from a coupled transmitter, in view of the large capacity available in the primary circuit, than from a simple MARCONI transmitter at the same potential.

Closely related to this is another advantage of the coupled transmitter, viz., the oscillations can be so modified, one may say, so formed, as to be best adapted for a particular receiver. If it is important to have great amplitude for the waves emanated, this can be secured without bringing the damping so high as to be prohibitive. Again, if very low damping is desired, this also can be obtained without causing too great a reduction in the amplitude of the wave. It is for these reasons that in the one extreme case, where the greatest range is the object, as well as in the other, where the sharpest possible tuning is the desideratum, coupled transmitters are always used.

c. As regards the *energy losses* it should be borne in mind that in the simple MARCONI transmitter, the spark gap lies in the antenna, while in the coupled transmitter the gap is transferred to the condenser circuit. As to which is the preferable location depends upon the particular circumstances.

One thing is certain: when the object in view is to radiate oscillations having the lowest possible decrement from a given antenna, the coupled, and above all, the WIEN transmitter is far superior to the simple MARCONI transmitter. In both cases, with the simple as with the WIEN transmitter, we obtain practically the natural oscillations of the antenna; but in the case of the simple transmitter, the spark decrement, which in itself is about as large as that of a weakly radiating antenna having no spark gap, is added to the decrement of the antenna of the WIEN transmitter.

d. The additional advantage of BRAUN'S coupled transmitter is that the *upper partial oscillations* of the antenna are not produced with an appreciable amplitude. This energy loss is therefore not involved. But in the BRAUN transmitter, at least when closely coupled, a second wave is obtained, which consumes energy, but is of no value for the distance effect in the customary receiving arrangements.

e. A further material advantage of the coupled transmitter lies in the fact that the antenna is charged, not directly by the induction coil or

transformer, as is the case with the simple transmitter, but only by the oscillations. The result is that the *insulation of the antenna* becomes a much simpler problem and that when slight faults occur in the insulation these have but little effect upon the oscillations [Art. 43]. In the simple transmitter, the slightest defect in the insulation suffices to endanger the entire operation.

There is a natural tendency to belittle this last element and to assume that good successful insulation can present no serious technical difficulties. The fact remains that insulation troubles, especially in the tropics, are often so great, that they have caused the failure of entire installations¹⁹² [see Art. 126].

120. Comparison of the Braun and Wien Transmitters.—*a.* The main advantages of the WIEN transmitter as compared to the BRAUN transmitter are as follows:

1. In the BRAUN transmitter the oscillations and hence the energy consumption in the primary circuit last as long as in the secondary. In the Wien transmitter they last only for a few periods.

2. The BRAUN transmitter produces *two* waves in practice, of which only *one* is fully made use of in the receiver. The WIEN transmitter emits practically only one wave from its antenna [Art. 78c].

As regards this second point it is of course possible to prevent the formation of two waves by means of *very* loose coupling [Art. 105], but then the transfer of energy to the secondary circuit becomes very inefficient. The former frequent practice of making the coupling just sufficiently loose to make the two coupling waves only slightly different in their wave-length, is of little or no use. The two coupling waves in that case act upon the receiver like a single wave of much higher damping, which makes the advantage of the coupled transmitter more or less illusory.

As to the first point, this would absolutely fix the superiority of the WIEN transmitter, so far as efficiency is concerned, if the same potentials and the same spark gap were used in the BRAUN and WIEN transmitters. But, as a matter of fact, a relatively long spark gap, with resultant low gap decrement [Art. 11*d*], is used in the BRAUN transmitter, while either low potentials and short gaps or high potentials and a series of gaps, *i.e.*, in either case, a high gap decrement [Arts. 11*d* and 12] are used in the WIEN transmitter. Hence the energy consumed *per cycle* is much greater in the WIEN than in the BRAUN transmitter, so that the total energy loss in the gap circuit of the WIEN transmitter may be quite considerable in spite of the short duration of the oscillations.*

* This no doubt is also why it is so important to have the coupling in the WIEN transmitter as close as possible, thereby minimizing the duration of the primary oscillations, without, however, making the coupling so close as to impair the quenching action.

Nevertheless the modern WIEN transmitters seem to be much more efficient than the old BRAUN transmitters.* But in acknowledging this it must be remembered that formerly fundamental principles in the construction were often disregarded either for the sake of convenience or for other specific reasons; some of the old transmitters actually appear as if they had been intended not merely for telegraphing, but also for warming the room in which they were located by the heat developed by the eddy currents. In the meantime experience has taught the necessity of applying the principles discovered in the laboratory to commercial stations so as to minimize all losses of energy. Hence we should not compare an old, poorly constructed BRAUN transmitter with a new, WIEN transmitter designed and constructed with the proper care.

It is readily conceivable that the *mechanically quenched gaps* should have high efficiency, as the use of long sparks and therefore low gap decrements is here possible. In any case, MARCONI'S combination of mechanical quenching with short-circuiting the gap must be very efficient, for it unites good quenching action¹⁹¹ with low energy consumption in the condenser circuit.

Quenching tubes also permit the use of long sparks with low gap decrements. Their use can give very good efficiency—M. WIEN⁹² obtained 80–60 per cent. efficiency (ratio of secondary to primary energy) at 30,000–80,000 volts primary—although the energy loss in the tube is added to that in the spark.

b. The use of high initial voltages and long sparks in the BRAUN transmitter is not accidental. Nor does the reason lie solely in the lower decrements of the long sparks. For in the BRAUN transmitter, of the two possible methods of increasing the energy of the transmitter (*i.e.*, increasing either the initial voltage or the spark frequency) only the former can be done in a simple way, the latter involving considerable difficulties. If the gap has stationary electrodes, then, even with such large dimensions as belong to the spark gap shown in Fig. 217, local heating of the electrodes, with all its attendant disadvantages (arcs, reduced breakdown potential), is unavoidable, if the spark frequency is brought to the region of 1000 cycles per sec. The use of rotating electrodes, however, is in-

* COUNT ARCO¹⁶⁰ claims that the efficiency (energy of the secondary divided by the primary energy) of the TELEFUNKEN quenched gap transmitters is about 85 per cent.¹⁹³

M. WIEN¹⁷ obtained the following figures from a very carefully designed BRAUN transmitter at an initial potential of 72,000 volts: $d_1 = 0.034$, $d_2 = 0.175$, $K' = 0.032$, $\eta = 82$ per cent. and for $d_1 = 0.034$, $d_2 = 0.087$, $K' = 0.024$, $\eta = 66$ per cent. ($\eta =$ efficiency). Such high efficiency, however, is attained only by the most careful construction of the primary circuit; as soon as WIEN replaced the compressed gas condensers he was using by MOSCICKI condensers, the efficiency dropped from about 80 to about 69 per cent. The efficiency of the BRAUN transmitters which were used in practice was much lower.

herently a complication, so that this means is hardly apt to be chosen except for large stations [see Art. 114a].

In the WIEN transmitter these conditions are more favorable. Here the oscillations in the primary circuit are only of very brief duration, so that the heat developed in the gap, at the same current amplitude, is much less. Furthermore the deionization of this type of gap is in itself so rapid, that there is but little tendency to form an arc. Hence, the use of high discharge frequencies involves no difficulties in the Wien transmitter [see Art. 114b], and the result, namely, *a high, pure note in the receiving telephone and a lowering of the antenna potential, thereby reducing insulation difficulties*, has proven its value in daily practice.

c. In the WIEN transmitter, there is an important advantage, particularly for portable stations, in conjunction with the short duration of the primary oscillations, namely, the possibility of using condensers made of mica or similar dielectrics. The doing away of the series connection means a general simplification, not only for portable sets, but for all other stations as well [see Art. 112a].

The brush discharge on the condensers, which is very harmful in the BRAUN transmitter and necessitates undesirable complications [Art. 108a], is of no importance in the WIEN transmitter.

CHAPTER VIII

HIGH FREQUENCY MACHINES FOR UNDAMPED OSCILLATIONS

121. The Alexanderson-Fessenden Machines.—It is reasonable to expect, *a priori*, that undamped oscillations of high frequency can be generated by a machine in the same way that commercial alternating currents of lower frequencies are produced. But it is an exceedingly difficult problem when frequencies of the order of 10^5 cycles per sec. are to be obtained. First of all, at these high frequencies, the hysteresis and eddy current losses become very large; a radical attempt to prevent the former by building machines without iron was soon abandoned as impractical. Then the structural difficulties increase very rapidly as the frequency is raised. Assume that a frequency of 10^5 cycles per sec. is obtained at the maximum allowable speed of 20,000 r.p.m.;* then if the diameter of the rotor is 305 mm., † a path of only 3.2 mm. remains for the generation of each cycle, that is, 3.2 mm. is the maximum width available for a pair of armature coils with their insulation. And if this width is not to be further reduced, a high speed is unavoidable, thereby involving the well-known mechanical difficulties attendant upon rotation at such velocities.

In spite of these difficulties, N. TESLA's early efforts in this direction have been renewed again and again, particularly in America,¹⁹⁴ where FESSENDEN devoted himself to the problem. The high frequency alternators which through his influence were built for the NAT. ELEC. SIG. Co., by the GENERAL ELECTRIC Co. from E. F. W. ALEXANDERSON's¹⁹⁵ designs, probably represent the best which has been achieved in this field of work in the past.

a. The 100,000 cycle ALEXANDERSON alternator ($\lambda = 3000$ m.) is of the inductor type.

Fig. 256 is a diagrammatic cross-section of one of these alternators. The excitation is obtained by means of a single large field coil, S , which is wound around the entire machine and is supplied with direct current. The magnetic flux lines, M , of this coil pass through the iron cores, E_1 and E_2 , of the small armature coils, S_1 and S_2 . The only movable part, J_1 , has teeth or projections, Z , of iron, at its periphery. When one of these teeth is just between the armature coils, S_1 and S_2 , the magnetic flux, M , has a path almost entirely through iron, excepting only at the very small air gaps between the teeth, Z , and the cores, E_1 and E_2 ; in this position then,

*Speed of ALEXANDERSON's machine at a frequency of 10^5 cycles per sec.

† Diameter of ALEXANDERSON generator.

the magnetic reluctance is a minimum, the magnetic flux passing through the armature cores, E_1 and E_2 , a maximum. When, now, a space instead of a tooth lies between armature coils, the air gap, and hence the magnetic reluctance, are much larger, so that the amount of flux through the armature windings is very small. Hence as the movable part, J , rotates, the magnetic flux passing through the armature coils varies periodically between a maximum and a minimum value, so that an oscillatory e.m.f., whose frequency = the product r.p.m. \times number of teeth, is induced in the armature winding.

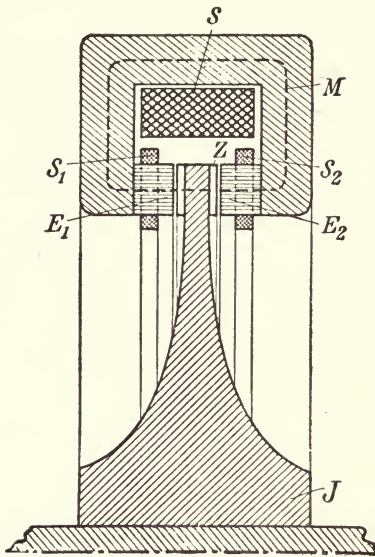

FIG. 256.

The rotor of ALEXANDERSON'S machine is shaped like the cross-section, J , in Fig. 256 and has 300 teeth. The space between the teeth is filled with a non-magnetic material (phosphor-bronze) so that the surface of the rotor, J , is quite smooth, thereby preventing any material loss due to air friction (windage).

The armature winding, in which the oscillatory e.m.f. is induced, does not, properly speaking, consist of coils, but of a single wire wound in a wave-

shaped form (Fig. 257); any two such consecutive U-formed wires may be considered as a pair of coils of one turn each, joined in series but so as to oppose each other. Fig. 258 shows one-half of the completed armature.

The capacity of the machine—shown with its D.C. motor in Fig. 259*—increases as the air gap between the armature and the rotor is decreased. It was 2.1 kw. in one machine having a 0.37 mm. air gap. The author has no record of its efficiency.

b. A second machine with a frequency of 50,000 cycles per sec. ($\lambda = 6000$ m.) and a capacity of 35 kw. is shown in Fig. 260. This alternator was also designed by ALEXANDERSON and has a diameter of about 1 m. Further details had not been published at the time of writing.

c. R. A. FESSENDEN¹⁹⁶ has described still another high frequency generator. Like ALEXANDERSON'S machine, it is also of the inductor type, but is characterized in that its movable portion (J , Fig. 256) acts at the same time as the short-circuited armature of an

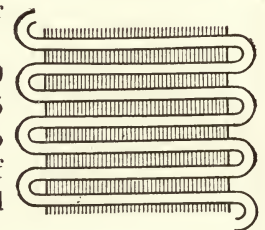

FIG. 257.

* High frequency alternator to the left, coupling in the middle and motor at the right. Diameter of alternator about 30 cm.

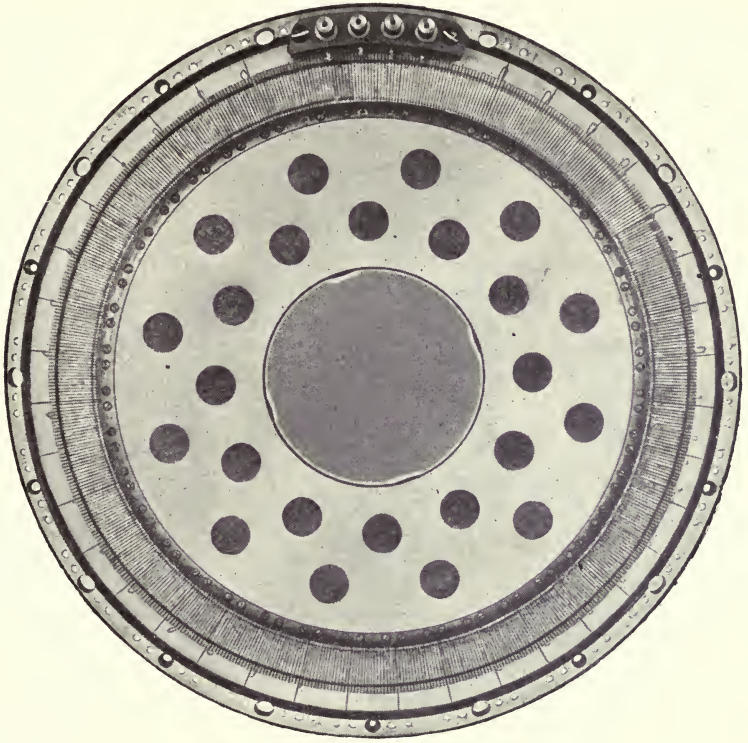

FIG. 258.

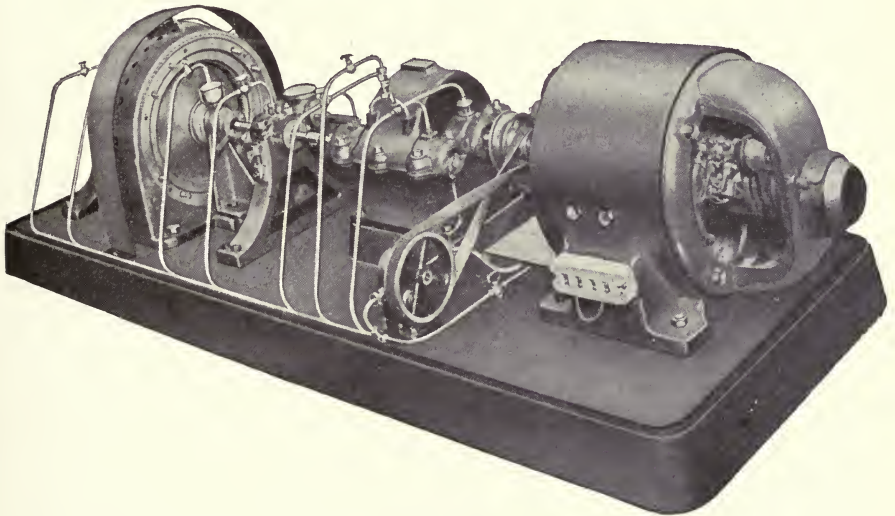

FIG. 259.

A.C. motor (A.C. frequency = 500 cycles per sec.). This machine is very simple in construction and is claimed to have given 2.5 kw. at $N = 1 \times 10^5$ cycles per sec.

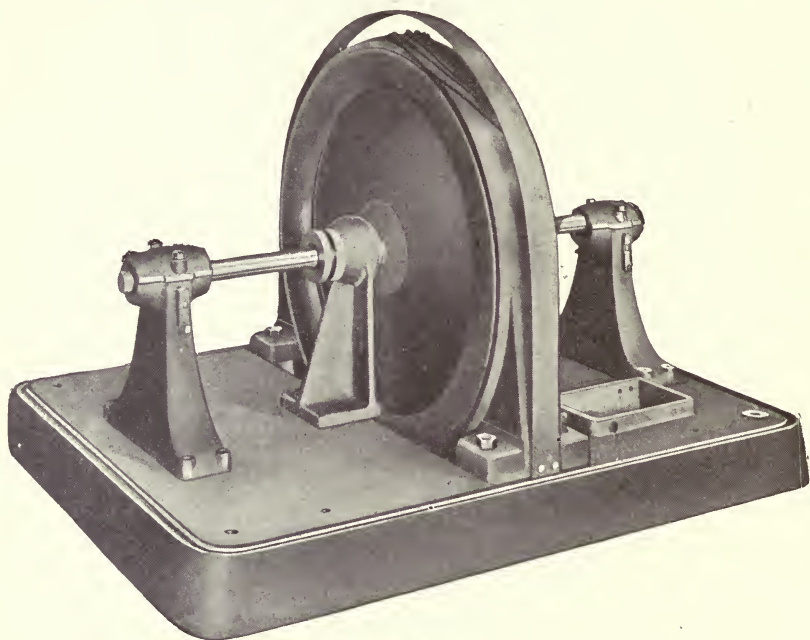

FIG. 260.

122. Goldschmidt's High Frequency Generator.—R. GOLDSCHMIDT¹⁹⁷ has attacked the problem of generating the high frequencies needed in radio-telegraphy along a different path.

a. The basis of his method is as follows:

If a coil, R (rotor), revolves in the magnetic field of a fixed coil, S (Fig. 261), through which a direct current is flowing, then the frequency, N , of the e.m.f. induced in R is equal to the number of revolutions of R per unit of time. But if an alternating current of frequency N^1 flows through the coil S , it can be shown¹⁹⁸ that the e.m.f. induced in R may be considered as made up of one e.m.f., \mathcal{E} , of the frequency $N + N^1$ and another, \mathcal{E}' , of the frequency, $N - N^1$.

What has just been stated in regard to the rotor with respect to the stator, must necessarily also hold for the stator with respect to the rotor; for as the induction depends only upon the relative motion of the two coils, the same result would occur if the rotor were held stationary and the stator rotated in the opposite direction. Hence we may state: If an alternating current of frequency N^1 is flowing through the rotor while the latter makes N revolutions per second, its field will induce an e.m.f., \mathcal{E} , of frequency $N + N^1$, and another, \mathcal{E}' , of frequency $N - N^1$, in the stator.

b. Now consider the arrangement of Fig. 262. The storage battery, B , sends direct current through the stator winding, S . Then an e.m.f., ε_1 , of frequency N , where N = revolutions per second of the rotor, is induced in the rotor. This e.m.f. sends an alternating current, I_1 , of the same frequency through the short-circuited rotor winding. Then, according to *a*, there is in turn induced in the stator an e.m.f., ε_2 , of frequency $N + N = 2N$ and another, ε'_2 , of frequency $N - N = 0$; the latter, therefore, is not an oscillatory e.m.f.

The e.m.f., ε_2 , induces a current I_2 in the circuit comprised of stator winding, S , condenser, C , and the result of this current is that an alternating field, of frequency $2N$, is superimposed upon the constant magnetic field of the direct current.

This, according to *a*, results in an e.m.f., ε_3 , of frequency $2N + N = 3N$, and another, ε'_3 , of frequency $2N - N = N$ in the rotor, the latter

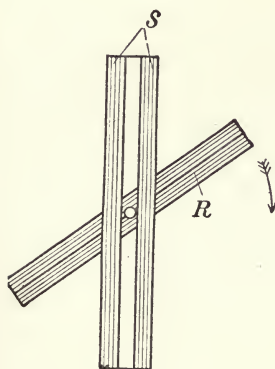

FIG. 261.

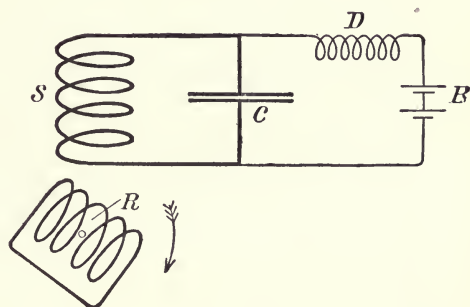

FIG. 262.

e.m.f., ε'_3 , adding itself to ε_1 . The alternating current I_3 , due to ε_3 and of frequency $3N$ flows through the rotor winding and, according to *a*, induces in the stator winding, S , an e.m.f., ε_4 of frequency $3N + N = 4N$ and another, ε'_4 , of frequency $3N - N = 2N$, the latter having the same frequency as ε_2 , upon which it is superimposed—and so on.

The *result* of the arrangement of Fig. 262 must therefore be the formation of alternating currents whose frequencies are $2N$, $4N$, $6N$, etc., in the stator and N , $3N$, $5N$, etc., in the rotor.

c. However, what is needed for radio-telegraphy, is an oscillation of *one single* frequency in the antenna. To obtain this, GOLDSCHMIDT—this comprises the second essential feature of his method—makes use of the *resonance* principle, by means of which he brings the amplitude of the oscillation desired for actual service and of those oscillations which determine this useful oscillation, to such high values that the amplitudes of the other oscillations disappear by comparison.

Fig. 263 is the diagram used by GOLDSCHMIDT himself to explain this method. The circuit $RC_3D_2C_4$, which is tuned to the frequency N , serves to strengthen the current I_1 ; the amplitude of the rotor current depends only upon the *ohmic* resistance* of this circuit. At most only a *very small* part of the current, I_1 , flows through the condenser C_5 , for at the

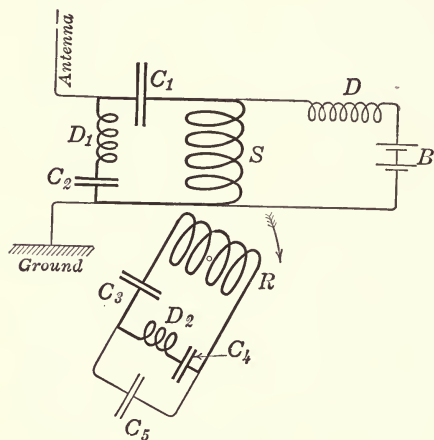

FIG. 263.

frequency, N , the inductance of the winding D_2 is made equal to the condensance (or capacity reactance) of the condenser C_4 :* hence the impedance of the branch D_2C_4 becomes much lower than that of the branch containing C_5 , whose impedance is simply the condensance of condenser C_5 .

The stator current I_2 , of frequency $2N$, attains a very great *amplitude* due to the fact that the circuit $SC_1D_1C_2$ is tuned to the frequency $2N$. Furthermore this current is prevented from flowing into the antenna because the in-

ductance of the winding D_1 = the condensance of C_2 at the frequency $2N$.

The resonance circuit for the *rotor* current I_3 , whose frequency is $3N$, is RC_3C_5 .

The circuit SC_2 -antenna-ground† is tuned to the frequency, $4N$, of the useful current, I_4 . The latter flows with any appreciable amplitude *only* through the antenna and not through the shunt D_1C_2 , as the impedance of this shunt is much greater, at *this* frequency than the condensance of the antenna capacity.

If it were desired to use the frequency $3N$, the antenna would have to be connected to the rotor in place of the condenser C_5 , and the condenser C_2 and inductance D_1 could be omitted from the stator circuits, if C_1 were

* It is well known that the current, I , in a circuit consisting of capacity, C , self-induction, L , and resistance, R , when the impressed or induced potential is V_0 , is given by

$$I_0 = \frac{V_0}{\sqrt{R^2 + \left[\omega L - \frac{1}{\omega C}\right]^2}}$$

So that if $\omega L = \frac{1}{\omega C}$, we obtain

$$I_0 = \frac{V_0}{R},$$

i.e., only the *ohmic* resistance, R , determines I [see Art. 67b].

† The antenna-ground circuit may, for the purpose in view, be considered as simply a condenser.

properly dimensioned. This would materially simplify the connections but, of course, the frequency would only be brought to three times the initial frequency, the latter being determined by the number of poles and speed of the machine.

d. At the right of Fig. 264 is shown a GOLDSCHMIDT machine which was put into service by the C. LORENZ Co. at the EBERSWALDE station in April, 1910. The driving motor is at the left and in the center is a gear case,

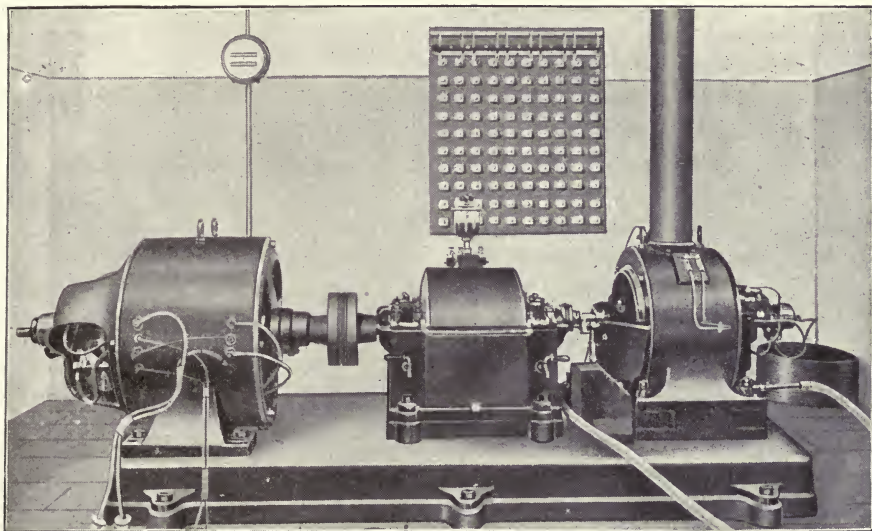

FIG. 264.

needed to bring the comparatively low motor speed up to the high speed required by the generator. The latter, of course, is of multipolar construction and gives 12.5 kw. at a frequency of 3×10^4 cycles per sec. ($\lambda = 10,000$ m.) with an efficiency of 80 per cent., and 8 to 10 kw. at 6×10^4 cycles per sec. ($\lambda = 5000$ m.).*

* In regard to the high frequency generator of COUNT ARCO (*Telefunken*) and his method of frequency transformation,¹⁹⁹ see the remarks at the end of the book concerning developments in radio-telegraphy during the last few years.

CHAPTER IX

UNDAMPED* OSCILLATIONS BY THE ARC METHOD

1. THE VARIOUS ARRANGEMENTS

123. The Problem and Its Solution by V. Poulsen.—The requirements which undamped oscillations must meet in order to be of use for radio-telegraphy are as follows:

1. Their *frequency* must lie within the range used in wireless telegraphy (*i.e.*, N must be between about 10^6 and 4×10^4 cycles per sec., corresponding to values of λ from 300 to 8000 m.).

2. Their *energy* must be sufficiently great, and

3. Their amplitude and frequency must be nearly enough *constant* for radio purposes.

The arrangement by means of which undamped oscillations can be produced in a condenser circuit is that shown in Fig. 244, in short it is the same as that by means of which a quenched gap circuit can be excited with direct current. Whether this arrangement will give undamped or damped oscillations depends upon the construction of the condenser circuit, the nature of the gaseous gap, F , the dynamo voltage, the resistance and self-induction of the supply circuit and, finally, upon whether, and if so to what extent the condenser circuit is coupled to a secondary circuit.

a. ELIHU THOMSON and N. TESLA, later also R. A. FESSENDEN, made early²⁰⁰ use of this arrangement for the purpose of continuously exciting the natural oscillations of a condenser circuit by means of direct current [Art. 115]. It is highly improbable that either THOMSON or TESLA succeeded in actually obtaining undamped oscillations of such frequency and energy as come into question for radio-telegraphy. THOMSON'S spark gap (the arc) had solid metallic electrodes in air at atmospheric pressure; with such electrodes, however, and potentials of not much more than 1000 volts, it is hardly possible to obtain undamped oscillations at

* By "*undamped* oscillations," the author understands oscillations of which the *amplitude remains unchanged from period to period* (in the arc method, oscillations of type *I* or *II* [Arts. 130 and 131]). The designation "*continuous*" oscillations is also frequently used. But against the use of this term stands the existence of continuous oscillations whose amplitude varies from period to period (see Fig. 290 and Art. 109*e*). The name "*continuous*" is therefore not sufficiently specific for the case in question.

high frequency, of sufficient regularity to meet even the most modest radio requirements. TESLA made some use of carbon electrodes, which are far more apt to make the production of undamped oscillations feasible; but even if he obtained undamped oscillations, their frequency cannot have been very high, as even his highest discharge frequency gave an audible tone.

Then, somewhat later, W. DUDELL²⁰¹ experimented with the arrangement of Fig. 244 using carbon electrodes and undoubtedly obtained undamped oscillations in this way. In fact he at that time discussed the essential condition for their production and through his experiments this method of generating oscillations became quite popular.

Soon after this the action of damped oscillations as used in radio-telegraphy was investigated more thoroughly and the advantages of low damping in the transmitter became evident. From then on undamped oscillations were the sole aim of nearly all working in this field. But difficulties were encountered when it was attempted to bring the frequency up high enough for radio purposes with DUDELL'S arrangement. Hence, after a long series of unsuccessful attempts it was concluded that it is impossible to obtain undamped oscillations of frequencies above 100,000 cycles per sec., with DUDELL'S arrangement using carbon electrodes for the arc. However, WERTHEIM-SALOMONSON²⁰² disproved this theory by obtaining oscillations at 400,000 cycles per sec., using DUDELL'S method. But the amount of *energy* which could be drawn from these oscillations was so slight, that his results could not yet be considered a practical solution of the problem of generating undamped oscillations for radio-telegraphic purposes.

b. This problem was first solved by POULSEN.²⁰³ He soon showed that the arrangement of Fig. 244 would give undamped oscillations at radio-frequencies and sufficient energy, if modified as follows:

1. The gap (or arc, *F*, Fig. 244) is placed in *hydrogen* or a gas containing hydrogen.

2. The positive electrode of the gap (or arc) is of *copper*, preferably cooled by circulating water, retaining carbon only for the negative electrode.

3. A magnetic field is caused to act upon the arc (**magnetic blow-out**).

Furthermore, in order to improve the regularity of the oscillations, which is of great *practical* importance, we should add another requirement, viz.,

4. One of the electrodes (the carbon) is slowly revolved about its axis.

The *Poulsen* arrangement ("*Poulsen generator*," "*Poulsen arc*") is therefore in principle that shown in Fig. 265, in which, however, the necessary auxiliary apparatus for rotating the one electrode is omitted. The two iron cores with direct current flowing through their windings provide the magnetic blow-out.

The requirements as given by Poulsen are not of equal importance. A hydrogen atmosphere in the arc, perhaps in conjunction with the particular materials chosen by him for the electrodes, suffices to secure the high frequency needed for radio-telegraphy with sufficient regularity of the oscillations. The magnetic field is required only—and apparently is even then not absolutely essential—if a very great amount of energy is wanted from the condenser circuit.

c. The TELEFUNKEN Co.²⁰⁴ arrived at a somewhat different solution

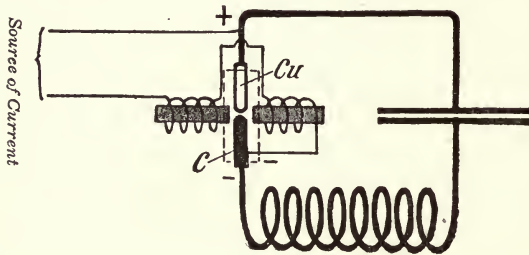

FIG. 265.

of the problem through tests made at the suggestion of H. TH. SIMON. The Telefunken "high frequency lamp" is characterized by the following points (Fig 266):

1. As in the POULSEN generator, the negative electrode at the arc is of

carbon, the positive, of copper, the latter being water-cooled.

2. The arc burns in a hollow in the copper electrode, hence in the gases or vapors produced by the arc.*

3. A number of such arcs are joined in series.

Fig. 267 illustrates the construction of one of these lamps; this form was used for a time in connection with wireless telephony, but is no longer in use.²⁰⁵

124. Commercial Construction of the Poulsen Generators.†—a. Figs. 268 (C. LORENZ Co.) and 269²⁰⁶ show the earliest construction of the POULSEN generator with transverse magnetic field, according to the diagram of Fig. 265. The part containing the heavy cooling vanes which is known as the "flame chamber"

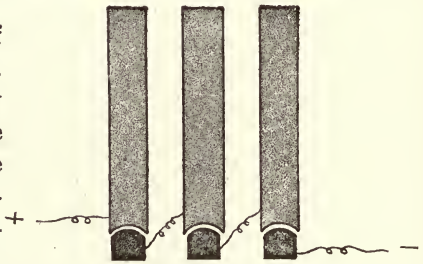

FIG. 266.

encloses the two horizontal electrodes which can be brought together for an instant at starting by means of a lever arm (at the upper right of Fig. 268). The large coils with their iron cores furnish the horizontal magnetic field across the inside of the flame chamber, and the small motor serves to revolve the carbon electrode.

b. A second, considerably different form of construction used for radio-

* Similar to the burning of flaming arc-lamps.

† The credit for developing the construction of the POULSEN generators rests with the former AMALGAMATED RADIO-TELEGRAPH CO. (in particular with MR. RAUSCH VON TRAUBENBERG²⁰⁷) and the C. LORENZ Co.'s telephone and telegraph works.

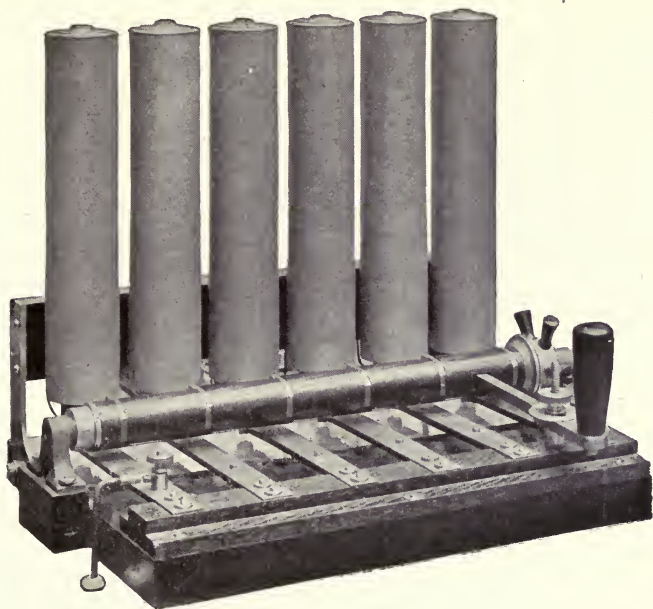

FIG. 267.

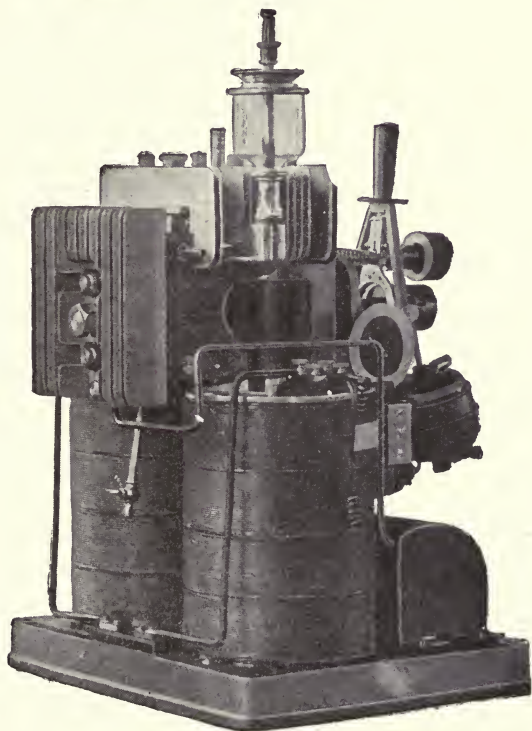

FIG. 268.

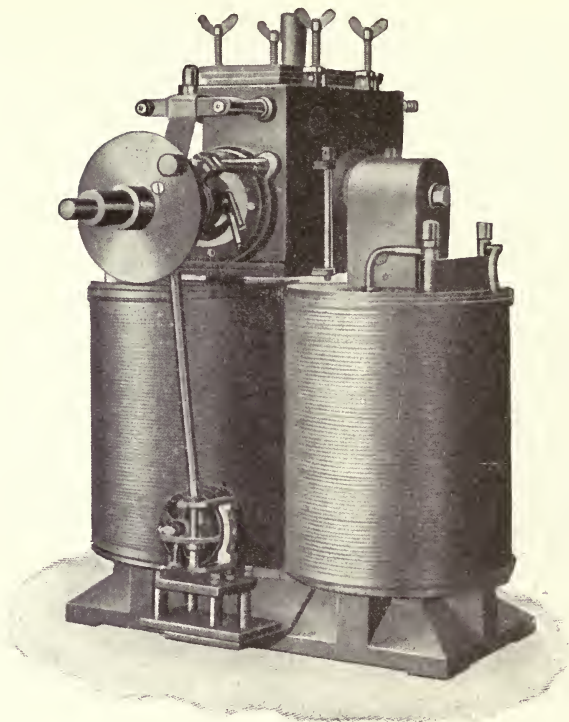

FIG. 269.

telephony and wherever there is no need of great amounts of energy, is shown diagrammatically in Fig. 270. The arc is vertical, the copper electrode, which is formed with large vanes (R), is at the top and the carbon electrode, which is made of a short piece of homogeneous carbon, is at the bottom. The magnetic field is produced by a single winding, S , having a vertical core, E_1 , and the course of the magnetic lines of force is guided by means of an iron ring, E_2 , at the end of the copper electrode. The effect of the magnetic field is to cause the arc to move slowly about in a circle.

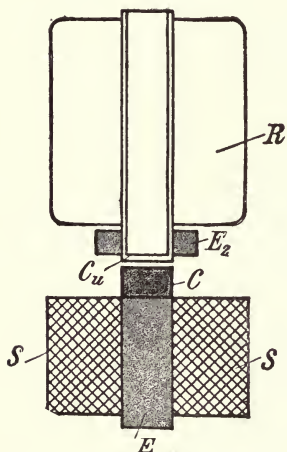

FIG. 270.

An actual construction of this form of PoulSEN generator is shown in Fig. 271.

The principal object attained by the magnetic field of this second form is that the arc is constantly moving about from point to point, so that rotating the electrodes becomes superfluous. The disadvantage of this form, however, is that this arrangement makes it impossible to secure the same magnetic field strengths or

to use them to their best advantage, so that it is not possible to obtain as high energy in the oscillations as with the form having a transverse magnetic field.*

c. The *hydrogen atmosphere* was formerly obtained by causing a stream of hydrogen gas to flow through the case of the POUlsen generator.

The hydrogen was either taken directly from tanks, as marketed, or chemically prepared in special apparatus by the decomposition of water.

The method lately in common use is much simpler. A small feed cup similar to lubricating oil cups (see Figs. 268 and 269) is located over the case and is filled with alcohol which continuously drips into the flame chamber where it is vaporized.

125. Use of the Poulsen Arc for Measuring Purposes.¹¹⁵—For measurements, maximum regularity of the oscillations, rather than a great amount of energy is the

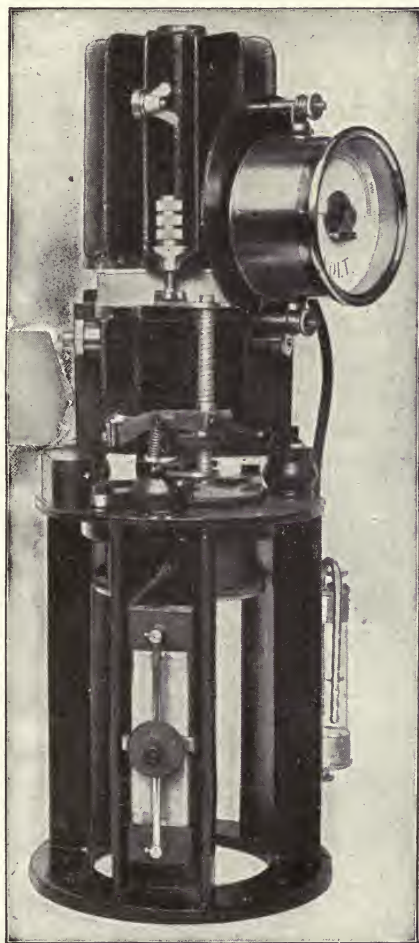

FIG. 271.

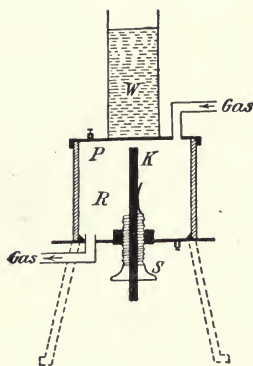

FIG. 272.

essential. Therefore a *transverse magnetic field is undesirable* as it does not tend toward constant regularity [Art. 136c]. Moreover

* The KNOCKROE²⁰³ Station, which was operated with 10–15 kw. oscillatory energy, had a transverse field of 10,000 lines of force per sq. cm. The CULLERCOATS²⁰³ Station (5 kw.) was equipped with a POUlsen generator of the second form. The energy which can be drawn from the oscillations is claimed to be about 19 per cent. of the total energy supplied by the D.C. generator.²⁰⁷

it is very important that the condenser is not of too great capacity [Art. 135c].

a. For some purposes the simple form of lamp shown in Fig. 272 (F. KIEBITZ) suffices: *P* is a copper plate or disc cooled by water on top and *K* is an adjustable carbon electrode. Hydrogen bubbled through acetone is recommended for the atmosphere in the arc chamber.

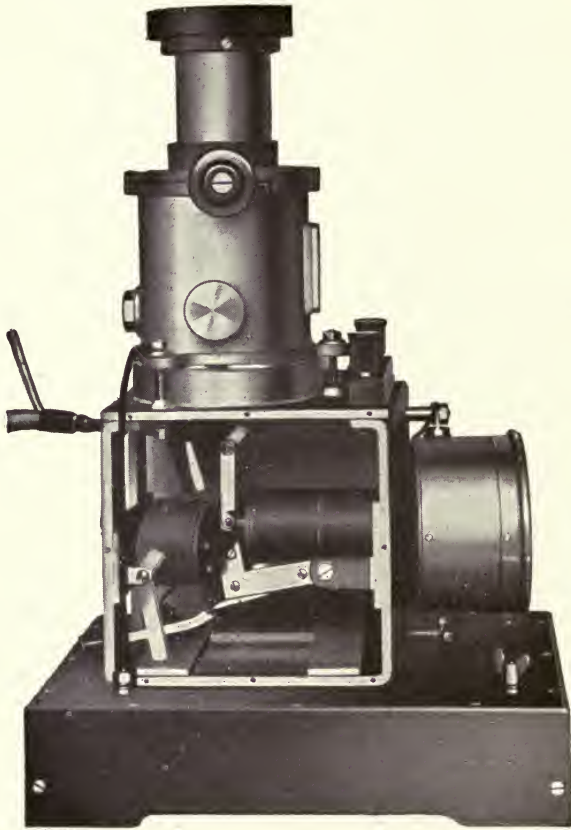

FIG. 273.

b. The Physikalisch-technische Reichsanstalt has designed a POULSEN generator for measuring purposes which gives particularly constant oscillations, but very little energy.

“In this lamp the arc burns between a cooled outer copper cylinder of 23 mm. inside diameter and 30 mm. high and the surface of a homogeneous carbon, 22 mm. thick. A magnetic field in the direction of the axis of the carbon and whose strength is adjustable, keeps the arc in constant rotation, thereby preventing the carbon from burning off unevenly. Three screws at the ends of the carbon serve for centering it with respect to the copper tube and are so arranged that this adjustment can be conveniently made even while the lamp is burning. The

magnetic field is produced by a coil through which the arc current flows. The current is furnished by a storage battery at 240 volts. A suitable series resistance can be conveniently made from *Nernst* iron resistors."

c. Fig. 273 shows a *POULSEN* lamp of the C. LORENZ Co., designed especially for measuring purposes. It is provided with an automatic regulating device (which can be seen under the lamp proper in Fig. 273) for the arc and is claimed to give very constant oscillations for long periods.

126. Circuit Connections of the Poulsen Transmitter.—*a. Coupled Poulsen Transmitter.*—In the first period following the discovery of *POULSEN*, the same method of working as in the *BRAUN* transmitter was used, probably universally, *i.e.*, the *POULSEN* generator was connected into a condenser circuit and the antenna coupled thereto.

To be sure, the condenser circuit of the *POULSEN* transmitter was quite different from that used by *BRAUN*. Of the requirements for the *POULSEN* circuit, *viz.*,

1. Lowest possible damping, and

2. Comparatively little capacity and large self-induction,

the latter is in direct contrast with those of the *BRAUN* transmitter, where the capacity is chosen as great as possible [Art. 106*d*]. The first requirement caused the use of air or oil condensers, to prevent the loss due to dielectric hysteresis which occurs in solid dielectrics. Moreover, the use of air or oil condensers involves no such difficulties with undamped oscillations as with the *BRAUN* transmitter, as in the former much lower potentials (at most a thousand, usually only a few hundred volts) and much less capacity* are used.

The coupled *POULSEN* generator is still in use for wireless telephone work (Chap. XIV), in exceptional cases also for wireless telegraphy.

The coupling between the primary circuit and antenna was inductive and loose in the *POULSEN* station at *KNOCKROE*.²⁰⁸ Occasionally, however, very close coupling was used. A medium degree of coupling is said to be undesirable, as this tends to make the frequency jump back and forth between two limiting values.†

b. The uncoupled Poulsen transmitter. If antennæ of relatively large capacity are used and coils of considerable self-induction are inserted in these, then the ratio of supplied to useful (converted) energy and of capacity to self-induction are about the same for a *POULSEN* generator

*The capacity of the *POULSEN* station at *KNOCKROE*,²⁰⁸ intended for transatlantic service was only 0.03 mf., while the *BRAUN* transmitter at *NAUEN* had 0.4 mf. and the *MARCONI* station at *CLIFDEN* had 1.6 mf. (air condensers) capacity [Art. 108*a*].

† It is usually stated that first one, then the other "of the two coupling waves" appears. The author is not aware, however, whether it has ever been proven that the two oscillations, which are apt to occur alternately in the *POULSEN* transmitter, are identical with the two oscillations which occur simultaneously in the coupled transmitter producing damped oscillations.

as for a normal condenser circuit. In this case, therefore, there is nothing to be gained by coupling the antenna to a condenser circuit and it is customary to connect directly into the antenna, which results in a particularly *simple* arrangement.

If the antenna capacity is relatively small the arrangement of Fig. 205 [Art. 98b]—the POULSEN arc being placed between *A* and *E*—is often used. This is frequently referred to as the “fly-wheel connection.”²⁰⁹

127. Devices for Producing Signals.—*a.* For telegraphing with damped oscillations a key which alternately makes and breaks the circuit is sufficient [Art. 116]. For undamped oscillations this is not so simple, for the following reasons:

The distance between the electrodes which is the most favorable for the production of the oscillations, is generally greater than the gap length which the dynamo voltage would jump across and form an arc. Hence it does not suffice to simply close the supply circuit by a key in order to ignite the arc.

This could be overcome in two different ways. Provision could be made by means of properly connected condensers, inductances and also transformers for producing a higher potential sufficient to form the arc, whenever the supply circuit is closed. Or again, the key could be so arranged that whenever it is closed the electrodes are brought into contact with each other or very close together.

Both methods, however, have a great fault. It is comparatively difficult to keep the frequency and amplitude of undamped oscillations constant. Hence it is of the greatest importance to leave those conditions, which affect the oscillations, unchanged. It is evident that if the supply circuit is continually opened and closed, it becomes practically impossible to obtain fixed conditions and oscillations of the requisite constancy.

It follows that in all devices intended for sending telegraphic signals, *i.e.*, for alternately transmitting and suppressing the waves, provision must be made for a *minimum effect upon the oscillations*.

b. The following are but a few of the many more or less successful arrangements which have been proposed for this purpose.

The arrangement of P. O. PEDERSEN,²¹⁰ illustrated diagrammatically in Fig. 274, is intended for use in the *coupled* POULSEN generator and seems formerly to have been used in all the POULSEN stations. If the left end of the key, *T*, is pressed down, the aerial is connected to the coil S_2 . Upon releasing *T*, the condenser circuit, $\overline{S_2CLR}$, is completed and oscillations induced in it by the primary circuit, *I*. The capacity self-induction and decrement of the condenser circuit, $\overline{S_2CLR}$, are made the same as the corresponding values of the aerial. Hence the primary circuit finds exactly the same conditions in the secondary in either position of the key.

For the case of direct connection of the antenna to the POULSEN generator, the C. LORENZ Co.²¹⁰ proposes the insertion of an iron resistance in series with a condenser circuit* in the antenna and short-circuiting both by means of a key when telegraphing.

c. In PEDERSEN'S¹⁸¹ apparatus for rapid telegraphing, a small portion

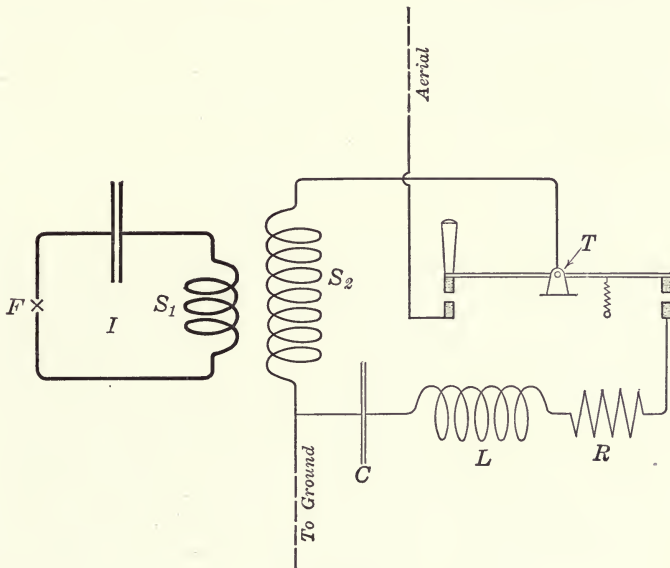

FIG. 274.

of the inductance inserted in the antenna is usually short-circuited so that the waves radiated by the antenna are somewhat shorter than the natural wave-length of the receiver. When signals are to be transmitted, this short circuit is then opened and the receiver responds to the waves.

128. The Multitone Transmitter of C. Lorenz.²¹¹—Aside from the direct application of undamped oscillations to radio-telegraphy, W. BURSTYN proposed the use of the undamped oscillations of a condenser circuit—the “tone circuit”—of relatively low frequency, for affecting the spark of a quenched gap circuit by the particular period of this tone circuit, so

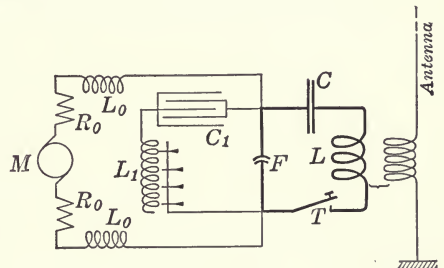

FIG. 275.

* The condenser circuit is connected into the antenna like that (ALBCA) shown in Fig. 205. The condenser circuit causes an increase in the wave-length of the oscillations, whose amplitude is decreased because of the energy consumed in the added iron resistance.

as to produce a tone of this period (or frequency) in the receiving telephone. (This is called a *tone transmitter*.)

Fig. 275 is a sketch of the connections. \overline{CLTF} is the quenched spark gap circuit. The supply circuit, L_0R_0 , is fed by the direct-current generator, M . The tone circuit, C_1L_1 , consisting of a large condenser, C_1 , and an inductance, L_1 , is connected in parallel to the spark gap, F . This condenser circuit oscillates (undamped) and the effect is about the same as if the direct current supplied by the dynamo had an alternating current (as from an alternator) of the same frequency as that of the tone circuit superimposed upon it.

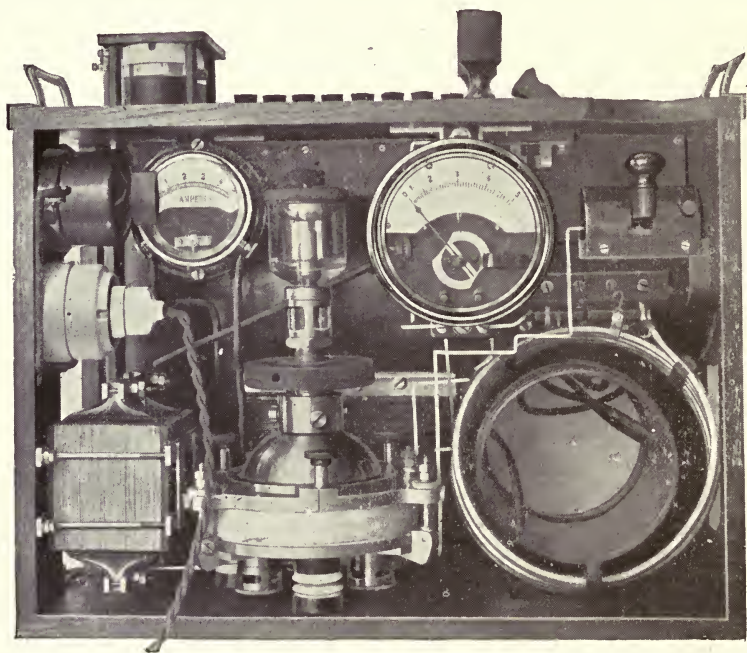

FIG. 276.

The C. LORENZ Co. has specialized in the construction of this arrangement under the name of "multitone" transmitter (Fig. 276). The condenser C of the diagram (Fig. 275) is the mica condenser seen at the lower left-hand corner of Fig. 276, and the spark is that shown in Fig. 233 [Art. 111*d*]. The coil L_1 is built with an iron core and can be seen back of the spark gap in Fig. 276. The electric constants are so chosen that the discharges of the circuit \overline{CLTF} (Fig. 275) are of the form discussed in Art. 109*e*, *i.e.*, we have a case of *impulse excitation*.

By means of a keyboard (on the top of the case in Fig. 276) various numbers of turns of the winding L_1 (Fig. 275) can be chosen, so that the frequency of the tone circuit and hence the tone in the receiving telephone can be very easily varied in this way. This simple choice of tone

forms an advantage of this method as compared to tone production by means of an alternator, although the latter of course offers a far greater range in the amount of energy used.

2. STUDY OF THE ACTION* OF THE ARC

129. Characteristic of the Arc.—Under the term *characteristic* of the arc (or of some other current carrying conductor) we understand a curve whose abscissæ are proportional to the current in the arc and whose ordinates are proportional to the potential difference between the electrodes.

a. Experimental Determination.—The *direct-current* characteristic (so-called “**static characteristic**”) is obtained by simply measuring the current with an ammeter, the potential with a voltmeter and then plotting the values so obtained in curve form.

If, however, the current varies with time as, *e.g.*, an *alternating current*, the characteristic may be found by means of the BRAUN tube, used as shown in Fig. 277.† The curve over

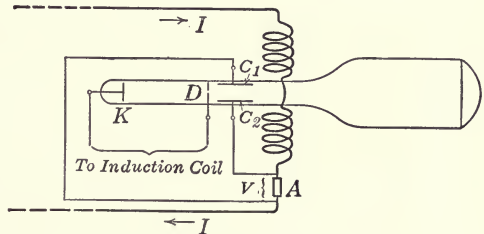

FIG. 277.

which the spot on the screen of the BRAUN tube moves, is the characteristic for that particular variable current (“**dynamic characteristic**”).

*b. The Static Characteristic of the Arc.*¹⁰⁷—In Art. 9b, it was shown that with direct current, within certain limits the voltage across the arc, V , in terms of the current, I , is

$$V = a + \frac{b}{I}$$

where a and b are constants. Hence, the characteristic is an equilateral hyperbola (Fig. 278). It is said to be a “**falling**” characteristic, as an increase in the current corresponds to a decrease in the voltage.

For very large currents

$$V = \text{constant} = a$$

* The explanation of what takes place in the arc method is due primarily to W. DUDDLELL, A. BLONDEL, H. TH. SIMON and H. BARKHAUSEN.²¹² There seems lately to have been a widespread impression that the work of these investigators effected POULSEN’s invention, *i.e.*, as if POULSEN had simply drawn more or less evident conclusions from existant theories. This, however, is an anachronism. POULSEN applied for his patents in 1902 and 1903, *i.e.*, 2-3 years previous to any of the theoretical work which might come into consideration.

† C_1, C_2 are small plates for the purpose of electrically deflecting the cathode rays; A is the conductor whose characteristic is being determined.

For very small currents, the equation given above does not hold, particularly when $I = 0$, V does not become infinity, but

$$V = V_z$$

i.e., equal to the discharge, "ignition," or breakdown potential which is just sufficient to jump across the gap. In Art. 42 it was shown that this value depends upon the shape of the electrodes and the distance between them, and also upon the nature of the gas in the gap. It is far greater than the potential which exists across the electrodes of the arc, while the latter is burning with even moderate intensity* [see Table V].

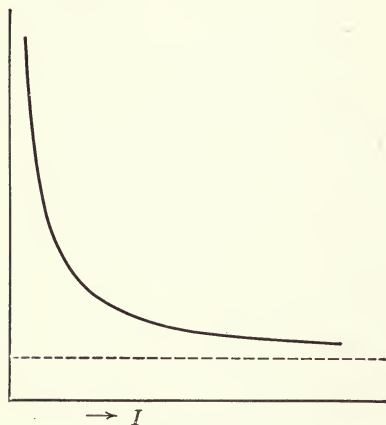

FIG. 278.

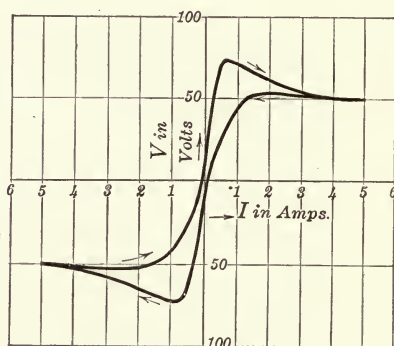

FIG. 279.

c. The *dynamic characteristic for alternating current* has the shape of the curve shown in Fig. 279. The following important points about it are noticeable:

1. The value of the potential corresponding to a given current value is not the same when the current is increasing as when it is decreasing. Also there is a phase displacement between the current and the voltage; the latter is not at its maximum at the same instant as the current.†

2. The discharge potential, V_z , *i.e.*, in this case, the potential at which

* If the distance between the arc lamp carbons is $\frac{1}{2}$ mm., then V_z is in general more than 1000 volts, while the potential, at the time the arc is burning, is of the order of 50 volts.

† As these relations are very similar to those which exist between magnetic force and magnetic field strength in iron, H. TH. SIMON²¹² has given the phenomenon the name of "arc hysteresis." These phenomena are closely related to the fact that the number of ions existing between the electrodes depends upon the current and the temperature of the electrodes at the *preceding instant*, the number increasing as the current and electrode temperature increase. Hence with rising current the number of ions is less at a given current value than with decreasing current at the same current value, and the voltage necessary to produce a given current is greater in the first case than in the second for the same reason.

the current passes through zero is comparatively very low, as the gaseous path remains ionized even after the current has disappeared. This is due to the fact that in an ionized gas a little time is always required before the ionization has entirely disappeared [Art. 65a], and also largely to the fact that the electrodes, as long as they remain incandescent, emit electrons which tend to ionize the gas [Art. 42c].

130. Type I Oscillations.— $I_{10} < I_0$. Consider the arrangement shown in Fig. 280. The resistance, R_0 , and the coefficient of self-induction, L_0 , of the supply circuit are first chosen so great that neither the current in the condenser circuit, CLR , nor the conditions existing in the arc can have an appreciable effect upon the supply current, I_0 , which may therefore be considered as constant.

In the case of type I oscillations, *i.e.*, oscillations in which the amplitude, I_{10} , of the alternating current is less than the supply current I_0 , the current curve* is of the form of the heavy full line curve shown in Fig. 281. It follows that we obtain an undamped, almost sinusoidal, alternating current in the condenser circuit with type I oscillations. The voltage across the arc is not sinusoidal, but varies about as shown by curve V in Fig. 289.

The characteristic of the arc with these oscillations† has the form of the heavy full line curve of Fig. 282. The values of the supply current, I_0 , and of the D.C. voltage, V_0 , corresponding to it‡ are shown as heavy dashed lines which divide the plane of the paper into four quadrants marked *I, II, III, IV*. Now, not only for type I oscillations, but in all cases where a direct and alternating current are superimposed the following condition holds: As long as the characteristic lies within the quadrants *II and IV*,

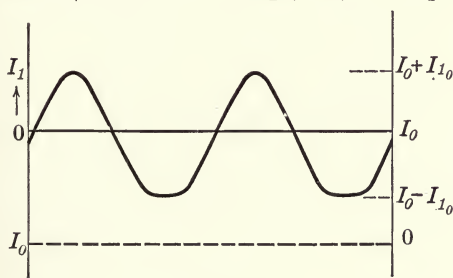

FIG. 281.

energy is added to the alternating current, while when the characteristic

* In Fig. 281 and the following figures the ordinates to the left represent values of I_1 , those to the right, of I (current in the arc = $I_0 + I_1$).

† And with homogeneous carbons and slow oscillations.

‡ In the static characteristic.

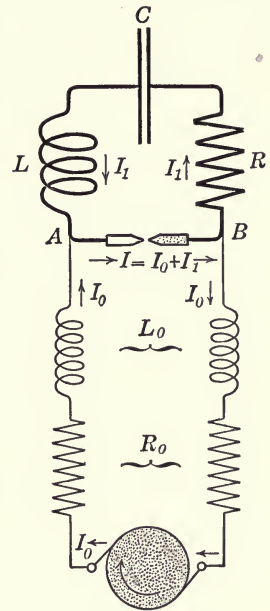

FIG. 280.

lies in the other two quadrants, *I* and *III*, energy is taken from the alternating current. The diagram, however, gives no indication of the amount of the energy changes.

131. Type II Oscillations.— $I_{10} > I_0$; **No Re-ignition.** As soon as the amplitude of the alternating current, I_1 , becomes greater than the supply current, I_0 , then during the half period in which I_1 , flowing through

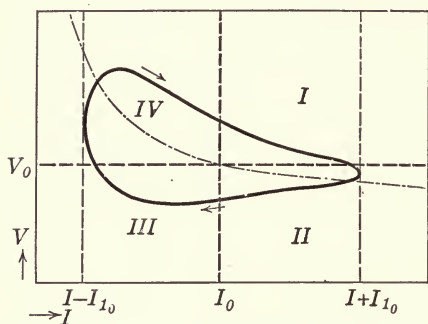

FIG. 282.

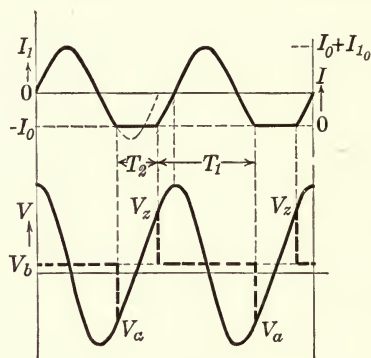

FIG. 283.

the path \overline{AB} (Fig. 280), has the opposite sign (direction) to that of I_0 , the current $I = I_1 + I_0$ in AB must = 0. Consequently the arc is extinguished and does not form again until the voltage, V , across the electrodes has reached the value of the breakdown potential, V_z .

a. Figs. 283, 284 and 285* represent a series of cases diagrammatically, under the assumption that the ignition of the arc takes place suddenly

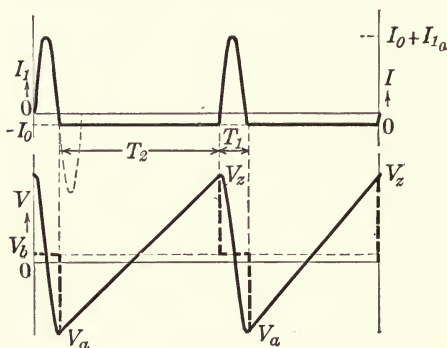

FIG. 284.

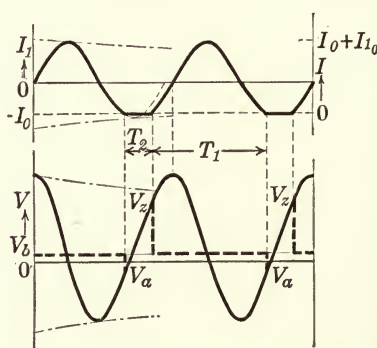

FIG. 285.

and that the voltage across the arc while burning, V_b , remains constant. Fig. 283 represents the case in which the current amplitude in the condenser circuit, I_{10} , is only slightly greater than the supply current I_0 ; in

* Figs. 283 to 287 and 290 are drawn from figures of H. BARKHAUSEN.²¹² In these figures the full line voltage curve represents the voltage between the condenser coatings, while the heavy dashed curve gives the arc voltage.

Fig. 284 I_{10} is much greater than I_0 . In both cases it is assumed that the damping of the natural oscillations of the condenser circuit is not appreciable (R is very small). The effect of having the natural oscillations more highly damped is shown in Fig. 285, which in all other respects represents the same conditions as Fig. 283.

In each period, T , there are *two different portions*, viz., the subperiod, T_1 , called the “**discharging stage**,” during which the arc burns (I is not zero), and the subperiod, T_2 , the “**charging stage**,” during which the condenser acquires its charge, the arc being extinguished and the current $I = 0$.

During the first subperiod, T_1 , the curve of the current, I_1 , in the condenser circuit is part of a sine curve*—i.e., we have an ordinary alternating current. During the second portion, T_2 , the current is a direct current $I_1 = -I_0$. The voltage, V , across the condenser coatings varies correspondingly: during T_1 it is oscillatory, during T_2 it rises from the value V_a , at which the arc was extinguished, to the value, V_z , at which it is again ignited, rising approximately in a straight line.†

The voltage, V , across the arc falls abruptly from the value, V_z , which it has at the moment of ignition, to the value, V_b , which it has during the

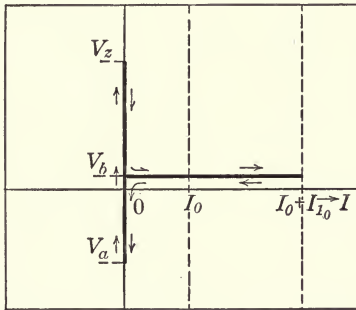

FIG. 286.

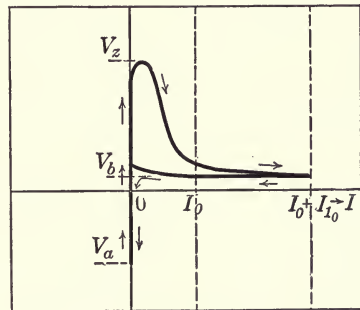

FIG. 287.

time of burning and then remains constant during the entire time T_1 . During the time, T_2 , in which the arc is extinguished, and hence no current is flowing through the arc, the voltage V is practically identical with V_c (voltage across condenser coatings); only with relatively high resistance, R_1 , and the consequent high damping, does V differ somewhat from V_c .

b. The assumed conditions governing Figs. 283, 284 and 285, would give an arc *characteristic* of the form of Fig. 286. *Actual experimental*

* With decreasing amplitude, if there is any damping.

† It is assumed that $I_0 = \text{const.}$ The actual form of the charging curve depends upon the capacity of the condenser, the resistance, R_0 , and the self-induction, L_0 (the dynamo voltage being assumed constant). If L_0 is very great then the charging curve is almost a straight line,²¹³ while if R_0 is very large and L_0 is very small, the curve is a more or less straight portion of an exponential curve.²¹⁴

observation, however, produces the form shown in Fig. 287. It follows therefore that the assumptions made in *a* are not quite correct. The ignition is not so sudden and the voltage does not fall abruptly from V_z to V_b , nor does it remain entirely constant while the arc is burning, but rises slightly just before the arc is extinguished. Hence the variation

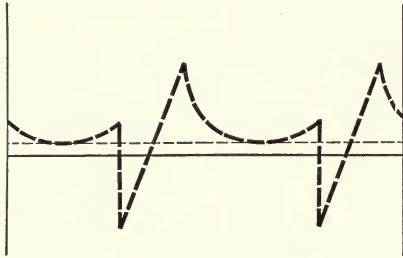

FIG. 288.

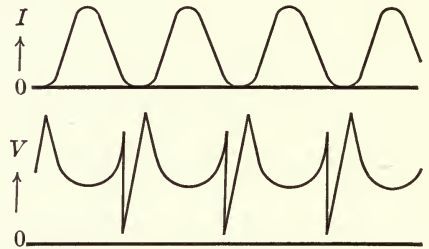

FIG. 289.

of voltage must be about as represented by the curve of Fig. 288. This compares well with the curve of Fig. 289 which A. BLONDEL²¹² determined experimentally.

There is another point in which the actual facts differ from the assumptions made in *a*, according to which the voltage V_c , across the condenser coatings could not rise above the terminal voltage of the dynamo. As a matter of fact it may under certain conditions rise to a much higher value.

That this may be possible is understood if we consider that a change

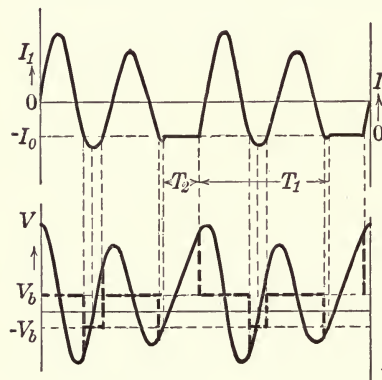

FIG. 290.

in I_0 —the previous assumption that I_0 is constant is not entirely correct—may produce higher potentials because of the self-induction, L_0 , by adding to the voltage across the condenser terminals [see Art. 115*b*]. Whether this is always the sole explanation is a question which need not be further investigated here.

132. Type III Oscillations $I_{10} > I_0$; Re-ignition Present.—Fig. 285 shows that at the moment the arc is extinguished, the voltage across the electrodes jumps from the normal value V_b to the value V_a . V_a is not as high as the ignition voltage V_z , which is just sufficient to start the arc at the end of the charging stage, T_2 . Under certain conditions in fact, the gas between the electrodes may still be so largely ionized immediately after the arc is extinguished, that a much lower voltage, *e.g.*, V_a , suffices to at once re-ignite the arc (“re-ignition”).

If this is the case, then the oscillatory discharge of the condenser continues, until finally the voltage V_a becomes too low to maintain the arc which is then extinguished. Hence, we obtain oscillations of the form of Fig. 290 or 291. The latter form is practically a representation of a rapid sequence of the natural oscillations of the condenser circuit. It is nothing more nor less than the form of oscillation whose practical application was discussed in Chap. VII.*

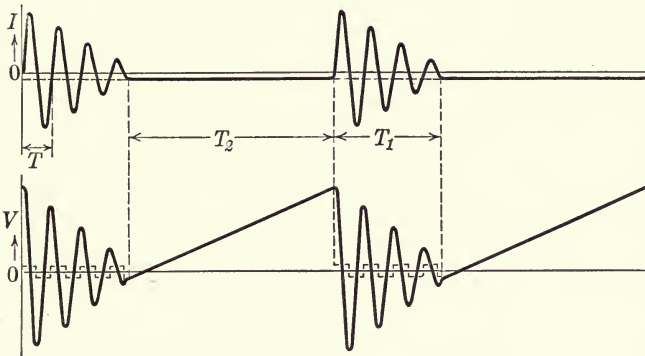

FIG. 291.

133. Energy of the Oscillations.—*a. Type I Oscillations.*—Experience has shown that these can not be produced so as to give great energy by such means as are known, the difficulty of obtaining high power increasing as the frequency becomes higher.

b. Type II Oscillations.—Under the same assumptions upon which Fig. 285 was based ($I_0 = \text{const.}$, $V = \text{const.}$ and during time arc is burning $V = V_b$), the energy which is supplied to the oscillation during one period by the direct current, and hence the maximum which can possibly be drawn from the oscillation, is approximately

$$\frac{1}{2} C(V_s - V_b)^2(1 - e^{-\frac{R}{2L} \cdot T_1})$$

where C , R and L are the capacity, resistance and coefficient of self-induction of the condenser circuit. Hence with R and L and also V_b constant, the energy increases very rapidly with increasing ignition voltage.

c. Type III Oscillations.—In the pure form of these oscillations (Fig. 291) we deal practically with the natural oscillations of the condenser

* The natural oscillations of a condenser circuit discussed in Chap. I are also practically the same as those described here. The difference is merely that in the case mentioned in Chap. I, the supply current is not constant or even nearly so, but varies widely with the time, being furnished from either an induction coil or an A.C. transformer.

circuit. The energy which is transferred *in one discharge*, is approximately [Art. 6b].

$$\frac{1}{2} CV_z^2$$

at the same time the highest voltage, V_z , which occurs across the condenser, may, under certain circumstances, be greater than the dynamo voltage (see Art. 131b). The energy consumed *per second* by the oscillations is

$$\zeta \cdot \frac{1}{2} CV_z^2$$

where ζ is the discharge frequency. This depends upon the rapidity with which the condenser becomes fully charged again after discharging; for a given capacity, it increases as the supply current, I_0 is increased.

134. Frequency of the Oscillations.²¹⁵—*a.* The frequency of *type I oscillations* is determined partly by the self-induction and capacity of the condenser circuit, partly by the characteristic of the arc. The frequency is always somewhat lower than the theoretical value of the natural frequency of the condenser circuit as obtained by THOMSON'S equation from the known values of the coefficient of self-induction and the capacity, but the difference is never very large.

b. In *type II oscillations* the period T consists of two parts, T_1 and T_2 . The length of the discharging period, T_1 , is determined first of all by the period of the natural oscillations of the condenser circuit and the ratio $I_{1_0} : I_0$; secondly, by the damping of the natural oscillations (see Figs. 283 and 285). The second or charging period, T_2 , is the interval from the time the arc is extinguished to the time it is again ignited. The period of the oscillation, $T = T_1 + T_2$, can therefore not be found even approximately by means of THOMSON'S equation, as it depends materially upon the rapidity with which the condenser becomes *charged*, *i.e.*, upon conditions in the supply circuit.

A consideration of practical importance is that not only the amplitude but also the length of the period and hence the *frequency varies if there is any slight change in the voltage at which the arc ignites*. This is what generally happens as soon as there is the least change in the electrodes. The extent of the change in T_2 depends largely upon the manner in which the voltage rises to the ignition point after the arc has been extinguished and upon the manner in which the voltage, V , across the electrodes rises.*

c. For the *pure type III oscillations*† (Fig. 291), practically the same

* At the points where the V curve (Fig. 283 *et seq.*) cuts the "ignition characteristic" (abscissæ \propto time, ordinates $\propto V_z$) the V curve must be much steeper than the ignition characteristic so that ignition always takes place promptly. The ignition characteristic becomes steeper, the more rapidly the ionization of the gas disappears.

† Type *II* oscillations of the kind shown in Fig. 290 are in general entirely irregular and quite useless.

may be stated as for the natural oscillations of condenser circuits produced by an induction coil or similar device [Chap. I]. The effect of the arc on the period* is not appreciable, the *frequency, therefore, is constant* and determined by the self-induction and capacity from THOMSON'S equation; as long as the distance between the electrodes is at least 2 mm. If this distance is very small, so that the deionization becomes very rapid, then in this case also, the frequency may be considerably lower than would be expected from THOMSON'S equation [Art. 5c].

135. Practical Conclusions† for Type II Oscillations.—Type I oscillations, because of their low energy are of no practical importance. *Only Type II oscillations are used for radio-telegraphy with undamped oscillations.*

In practice it is important to give the oscillations as much energy as possible‡ and to keep the frequency as nearly constant as possible.

a. The requirement of maximum energy leads to the maximum ignition voltage [Art. 133b]. This can be provided for in two ways, viz.,

1. By lengthening the charging stage, T_2 , as much as possible, so as to give the gas plenty of time to deionize.

2. By the use of special means for rapid deionization of the gas.

The first method involves the danger of destroying the constancy of the frequency [Art. 136c]. Moreover, the longer T_2 is made, the more does the current curve tend to differ from the sinusoidal form (see Fig. 284), *i.e.*, the upper partial oscillations come into prominence in addition to the fundamental. The energy of the partial oscillations is wasted, however, for in practice, when coupling or when using a tuned receiver, only the fundamental oscillation is effective.

As a matter of fact, therefore, it is best to work with oscillations in which the subperiod, T_2 , *is relatively short*, and in which, therefore, I_{10} is not *much* different from I_0 (Fig. 285).

b. Then, however, it is especially important to *obtain a very rapid growth of the ignition voltage by special means, i.e.*, to deionize the gas in the path of the arc as rapidly as possible. Necessary precautions for this result are as follows:

1. Removal of the ionized gas from the space between the electrodes.

The spontaneous deionization of the gas in the path of the arc, due to the ions recombining, is in general too slow to be effective at the high

* That is, the period of the damped oscillations (T in Fig. 291) which come into consideration for practical use.

† Strictly speaking, conclusions may be drawn from what has preceded only if the condenser circuit is not coupled to some other circuit. If it is loosely coupled to another circuit, the conditions will presumably change but very little, but with *close coupling they will change very much*. Systematic investigation of the coupling of Type II oscillations has to date been made only at low frequencies (S. SUBKIS^{97a}).

‡ The important thing, of course, is to *take* as much energy as possible *from* the oscillations.

frequencies involved. Moreover, as the electrodes are not so very close together as with quenched spark gaps, deionization by absorption at the electrodes and by an electric field cannot amount to much. Diffusion into the outer space is far more effective, particularly if the coefficient of diffusion of the gas in question is high; hence *hydrogen*, having the highest coefficient of diffusion, gives the best results. The most effective means of removing the ions in the space between the electrodes is the use of a *magnetic blowout*, as this acts while the current is still flowing, driving the arc and the gas contained in the arc out of the innermost recesses between the electrodes.¹¹¹

The use of a *mechanical air blower* for this purpose hardly offers any advantages. To be effective the velocity of the current of air or gas blown must be such that each particle of the air moves through a distance of at least 1–2 mm. during the half period of an oscillation (at $\lambda = 1000$ m., this would be 1.5×10^{-6} sec.). Such high velocities, however (600 to 1200 m. per sec. under the assumptions made), aside from the complications involved, would produce such eddies between the electrodes as to defeat the very object in view and make a complete removal of the ions in the path of the arc impossible, in spite of the high velocity.

2. Prevention of the ionizing effect of the incandescent electrodes, particularly of the anode. The following are various methods for preventing or at least reducing this effect.

a. Cooling the anode, at which the development of heat is particularly great.

Cooling the anode *as a whole* is relatively a simple matter. Water or air cooling, the latter preferably aided by ventilators or a ribbed construction of the anode, suffice. But it is much more difficult to prevent *local* heating at the point where the arc originates and at which the emission of electrons continues after the charging stage. This detrimental effect can be mitigated by:

α . Use of a metal having *very* high heat conductivity (as copper or silver) for the anode.*

β . Surrounding the electrodes by a gas having very high heat conductivity; in this respect, *hydrogen*, which has the greatest heat conductivity of all the gases, is best.

γ . Hydrogen, moreover, has the advantage of preventing the formation of metallic oxides and even reducing any previously existing oxides, which are particularly active in the emission of electrons when incandescent. This is also true to a certain extent of an enclosed arc-lamp.

b. *Rotating* one or both of the electrodes tends to reduce local heating only if it is so rapid that the base of the arc is moved sufficiently far in each period as to occur at a point not yet materially heated in the succeed-

*Homogeneous carbon is used universally for the *cathode*. This difference or asymmetry of the two electrodes is also of value in that it prevents re-ignition.

ing period. This, however, would require a speed of rotation of a much higher order than is ever used.

c. The subdivision of the arc into several partial arcs [Art. 123c] in series is often advantageous. With the same total voltage and the same current, about the same amount of heat is developed in all the partial arcs as in the equivalent single arc, but the heat *given off* is much greater in the combined partial arcs than in the single arc.

The problem of deionizing the gaseous path of the arc during the charging stage and keeping it deionized increases in difficulty, other things being equal, as the frequency of the oscillation is increased, the time available for the deionization being correspondingly shortened, and as the current and hence also the heating of the electrodes and the number of ions formed are increased. Therein lies the main explanation of the relative ease with which undamped oscillations of low frequency and energy can be obtained, while for a long time no one succeeded in obtaining undamped oscillations of such frequency and energy as are needed in radio-telegraphy.

c. *Amount of Capacity Allowable.*—Let the dynamo voltage and the frequency of the oscillations be given. Then the energy supplied to the condenser circuit per second is proportional to the capacity in this circuit [Art. 117b]. Hence, from this standpoint, a larger capacity is advantageous. On the other hand a larger capacity necessitates a larger current amplitude, I_1 , in the condenser circuit, and as this must not be much larger than the supply current, I_0 [see a], the latter must also be larger. But the greater the current through the arc becomes, the more intense will be the heating of the electrodes and the ionization of the gas in the path of the arc and the less effective, therefore, will be the curative methods given in b.

Consequently, indefinitely increasing the capacity soon becomes detrimental to the best results, so that in generating undamped oscillations by the arc method we are obliged to work with relatively *small capacity* and large self-induction in the primary circuit.

136. Regularity of Type II Oscillations (K. VOLLMER¹¹⁵).—It is evidently extremely probable that the burning of the arc causes the electrodes gradually to change, much more so, in fact, than in an oscillating damped condenser circuit of low discharge frequency, in which the gap is without current the greater part of the time. Every change in the path of the arc, however, will alter the ignition voltage and thereby the frequency and wave-length, as well as the energy and amplitude of the oscillations.

a. These fluctuations may be subdivided into the following classes:

1. Slight fluctuations in arcs without transverse magnetic field, these being either

- α. Rapid fluctuations, or
- β. Slow changes.

2. Great fluctuations in arcs having transverse magnetic field and caused by this field.

The *cause* for 1 in arcs with *no transverse magnetic field* is no doubt the following: The arc, while burning, eats its way into the electrode (or electrodes) thereby gradually lengthening the arc and increasing the ignition voltage, so that the frequency and amplitude of the oscillations are also gradually changed thereby. This continues until the arc finds more favorable conditions at some neighboring point, to which it then jumps with the result that the arc length, ignition voltage, frequency and amplitude also take a jump in the opposite direction. (The individual de-



Fig. 292.

pressions or cavities which the arc had eaten out, on its way around the hollow cylindrical electrode are easily recognizable in the accompanying photograph, Fig. 292.)

Tests have shown that changes in the wave-length and in the amplitude occur in conjunction with changes in the average arc potential, in fact the wave-length variation is directly proportional to the mean arc potential variation. Other things being equal, it (the mean arc potential variation) increases with increasing capacity, decreasing supply current and decreasing wave-length (increasing frequency).

The *extent* of the fluctuations depends very largely upon the *construction of the lamp*.¹¹⁵ In a lamp made by VOLLMER and copied from that of

the Physikalische Reichsanstalt, he found that when the adjustment was particularly good, at $\lambda = 2000$ m. the intensity variation was about 2 per cent., the frequency variation about 0.03 per cent., and at $\lambda = 700$ m. the frequency variation was about 0.18 per cent.

b. The *results* of these fluctuations are disturbances which interfere with the practical application of the oscillations as well as with any measurements.

The rapid intensity fluctuations which occur in lamps without a transverse field are harmless, as the measuring instruments or detectors used do not respond to them, but indicate the average value. The slow fluctuations, however, may at times be very annoying especially in connection with measurements.

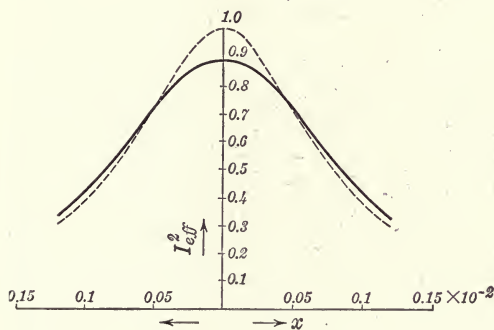

FIG. 293.

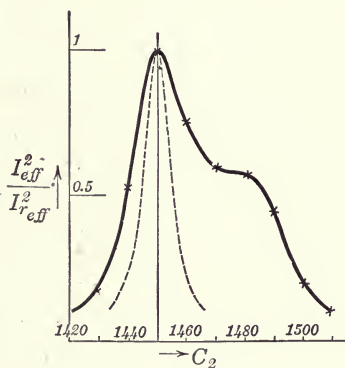

FIG. 294.

The frequency fluctuations interfere particularly if the arc circuit is very loosely coupled to a secondary circuit, (1) by flattening the resonance curve, reducing the sharpness of resonance and, (2) by materially reducing the current effect at resonance.

1. In Fig. 293 the broken line curve is the resonance curve which ought to be obtained by the action of an undamped oscillation of constant frequency upon a secondary circuit whose decrement, $d_1 = 0.005$. The full-line curve is the resonance curve obtained with the same secondary circuit, if the frequency (or wave-length) of the undamped primary circuit fluctuates back and forth at a uniform rate between the limits $\lambda + \lambda'$ and $\lambda - \lambda'$, λ' being only 0.05 per cent. of λ . It will be noted that even with this small fluctuation the resonance curve suffers a considerable flattening and reduction in height from its ideal form.

The resonance curves obtained from arcs with a transverse field are of the form of the full-line curve shown in Fig. 294 ($d_2 = 0.012$); here the difference from the dashed curve, which would be obtained with constant frequency using the same secondary circuit, is much greater. (The peaks of the two curves were drawn alike in height intentionally.) From the

shape of the curve it is evident that the fluctuations which occur are not symmetrical with respect to a mean value, but (similarly to the brush discharge of condensers [Art. 86]) the frequency lies mainly near a certain value (corresponding to $C_2 = 1450$) from which it gradually fluctuates to a lower value (corresponding to $C_2 = 1480$).

2. The changes in the *current effect* caused by the frequency fluctuations, may be quite considerable, as is shown by the following tabulation which is based on the assumption that the fluctuations are symmetrical, amounting to 0.03 per cent. on each side of the mean value to which the secondary circuit is tuned.

d_2	$\lambda = 2000$	$\lambda = 1000$	$\lambda = 500 \text{ m.}$
0.01	3 per cent.	24 per cent.	63 per cent.
0.03	0.5 per cent.	4 per cent.	16 per cent.
0.05	0.2 per cent.	1.5 per cent.	6.5 per cent.

Qualitatively, therefore, the effect of the frequency fluctuations is the same as if the primary circuit had constant frequency but material damping.

c. In Art. 125 it was already pointed out that a transverse magnetic field, which is very advantageous for the energy of the oscillations, is very disadvantageous for their regularity.* This is true not only of the transverse field, but more or less so of all agents which tend to increase the energy. The explanation of this fact is simple enough. The requirement for maximum energy is the most complete deionization of the gaseous path of the arc during the charging stage, while on the other hand a slight ionization or electrification of the gaseous gap is advantageous, in fact is essential with low potentials [see Arts. 42b and 78c] for a sure and accurate timing of the discharge. Hence we must fall back upon a compromise. This explains in part the use of carbon as the negative electrode, in spite of the fact that its low heat conductivity lowers the ignition voltage. This also explains why the strength of the transverse magnetic field is in general not made very great, sacrificing a further increase in the energy of the oscillations.

Somewhat of an exception to this rule is encountered in the use of *hydrogen*, one of whose properties tends greatly to increase the regularity of the oscillations; namely, the relatively low breakdown potential of hydrogen corresponding to a given gap length [Art 42c]. The consequence thereof is that with a given voltage (ignition voltage) the distance between the electrodes can be made considerably greater when hydrogen is used than, for example, with air. Hence any change in the arc length (say due to eating away or volatilization of the electrodes) amounts to a lower per-

* The extent of the fluctuations depends upon the construction of the lamp in this case also. Good regularity can be obtained with lamps having a transverse magnetic field (see Art. 191b), but this is a much more difficult attainment than with lamps having no transverse field.

centage of the initial length with hydrogen than with air, so that the resultant change in the potential and hence also in the wave-length and intensity is less than with air.

137. The Terms "Spark" and "Arc."²¹⁷—Doubt has occasionally been expressed of late as to whether the phenomenon in the gap constituted a "spark" or an "arc" in a given case.

In the two limiting cases there is never any doubt. Everybody speaks of "sparks" when, as in the early construction of the BRAUN transmitter, only a few, say ten to twenty discharges per second occur. Here the periods during which current flows through the gap are separated by long intervals of currentlessness, so to say, and the total time during which there is no current in the gap is much greater than the total time during which current flows through the gap. Here, then, both eye and ear receive evidence of intermittent discharges (limiting case *I*).

Again, everybody would call the phenomenon obtained in the gap between the electrodes, with undamped oscillations of type *I* or *II*, an "arc." In type *I* the gap is never without current, in type *II* the periods with and without current alternate so rapidly that neither human sight nor hearing can distinguish between them (limiting case *II*).

Between these two limiting cases, however, are various *intermediate forms*, e.g., the case of damped oscillations at a very high discharge frequency. Here the total time of currentlessness becomes about equal to or even less than the time of current in the gap; at any rate the eye can here no longer distinguish the individual discharges and the ear at best can discover the presence of intermittent discharges only in the tone or note emitted by the gap.* Whether, in this case, we speak of sparks on the basis that the form of the discharges is inherently the same as in limiting case *I*, or whether we speak of an arc, in view of the fact that in limiting case *II*, the duration of current is of the same order as the duration of currentlessness, is a matter of individual preference. At any rate, it is advisable in such a case to obtain by actual test (e.g., by means of a discharge analyzer or a BRAUN tube) an exact picture of the time variation of the discharges, rather than to dispute the propriety of the name given to the phenomenon in question.

* In scientific and patent literature it is often claimed for some particular device or arrangement that it will generate undamped oscillations. If such a claim is based solely upon the arc-like appearance or sound in the gap, it must not be accepted without further conclusive evidence.

CHAPTER X

PROPAGATION OF THE WAVES OVER THE EARTH'S SURFACE

1. OVER PLANE OR SPHERICAL HOMOGENEOUS GROUND²¹⁸

138. Ground Having Plane Surface and High Conductivity.*—Of these two assumptions, the latter is approximated in sea water. Under both assumptions we would have the following conditions.

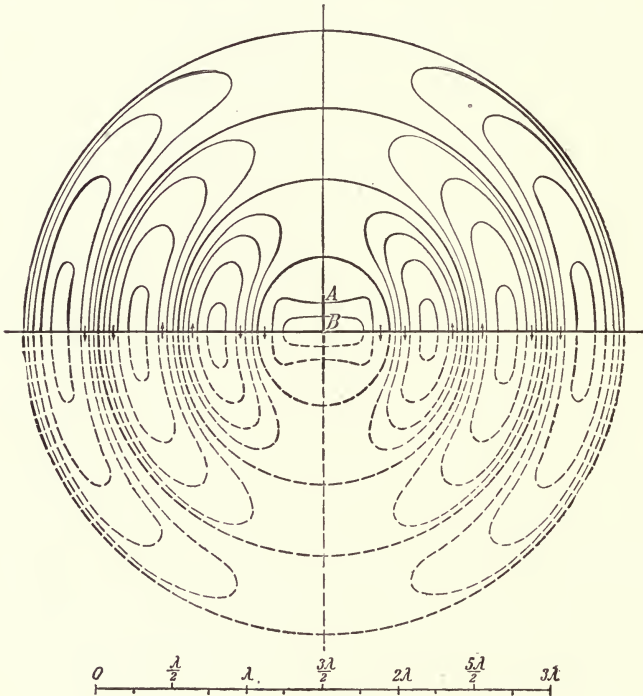

FIG. 295.

a. General Nature of the Field.—With a transmitter placed above the earth's surface, the following rule gives approximately † the form of the waves. Consider the ground removed and replaced by the image of the antenna, with respect to the earth's surface, so that the antenna and its image form two symmetrical halves. It is also assumed that the distri-

* That is the specific conductivity $> 10^{-12}$ c.g.s. units.

† The results would be absolutely *exact* if the conductivity of the earth's surface were infinitely great.

bution of current and potential is the same as exists in the symmetrical halves of the antennæ shown in Figs. 23, 42, 45 *et seq.*, *i.e.*, at any point, P , and its image, P' , the current must have the same direction but the potential is of opposite sign in each. The rule then is: The waves which the antenna with its image would radiate, if they were placed in free space, have the same course through the air as the waves which are actually radiated by the antenna placed above the earth's surface.²¹⁹

b. Effect of the Form of the Antenna.—From the preceding it follows that for a *simple antenna* (single straight wire), the electric field would be

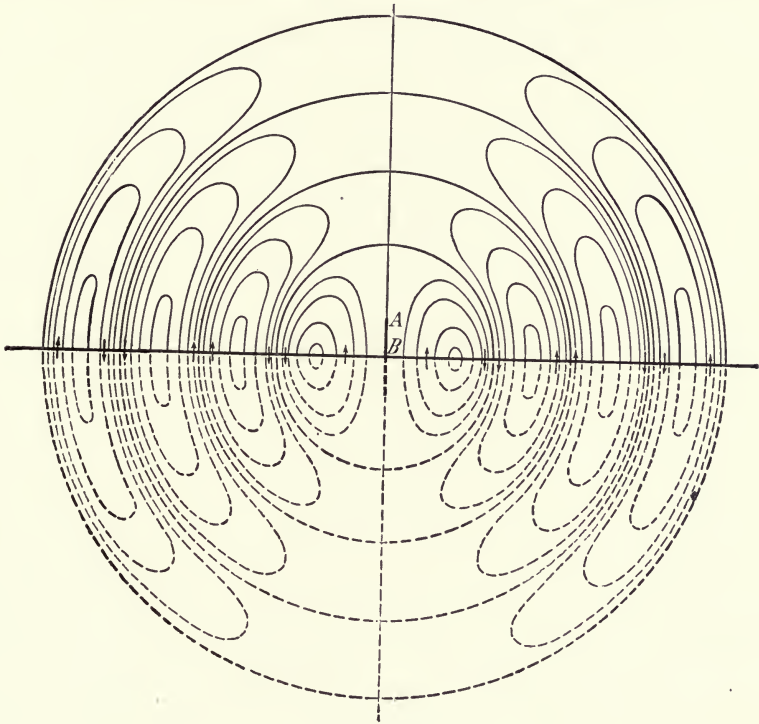

FIG. 296.

as shown by the upper halves of Figs. 295 and 296 [see Art. 20*a*], the former representing the instant of maximum charge, the latter, the instant of maximum current. As the distance from the antenna increases, the electric lines of force approach more and more the form of circular arcs. In Art. 20*a* it was stated that the magnetic lines of force are also circular.

With *other forms of antennæ* the shape of the wave in the vicinity of the antenna, up to distances of one or two wave-lengths, may be considerably different from that just described, though the general character of the field, particularly the snapping apart of the lines of force must be more or less the same in all forms of antennæ.²²⁰ The greater the distance from

the point of origin becomes, the more will the shape of the waves resemble that produced by a simple antenna.

c. *The Field at very great Distances from the Antenna.*—From Arts. 20a and 25a, the following may be concluded in regard to the field immediately above the earth's surface, at distances very great in comparison to the wave-length:

1. The *direction* of the electric lines of force is approximately perpendicular to the earth's surface, that of the magnetic lines parallel to it; both are perpendicular to the direction in which the wave moves.

2. The electric and the magnetic fields are *in phase* [Art. 20d].

3. The amplitudes of the electric and magnetic field strengths are expressed by

$$\left. \begin{aligned} E_0 &= 4\pi \frac{\alpha h}{\lambda} \cdot \frac{|I_0|}{r} \cdot 3 \times 10^{10} \text{ c.g.s. units} \\ &= 120\pi \frac{\alpha h}{\lambda} \cdot \frac{|I_0|_{amp.}}{r_{cm.}} \cdot \frac{\text{volts}}{\text{cms.}} \\ M &= 4\pi \frac{\alpha h}{\lambda} \cdot \frac{|I_0|}{r} \text{ c.g.s. units} \end{aligned} \right\} \quad (1)$$

where h represents the height of the antenna, I_0 the current amplitude at the current anti-node of the antenna, α the form factor of the antenna and r the distance from it. Accordingly, the amplitude of the field at great distances is inversely proportional to the distance r .

d. *Penetration of the Waves into the Ground.*—As the waves spread out over the earth's surface, they penetrate to some extent into the ground, but in so doing their amplitude is rapidly decreased. Thus in sea water of good conductivity,* at a depth of 1 m. the amplitude is only about one-tenth of its value above the surface, with a wave-length of about 700 m.*

139. Over Flat Ground of not very High Conductivity (A. SOMMERFELD).—If the earth's surface at the location in question has relatively low conductivity, as is the case even with fresh water, but particularly with dry ground,† the results are quite different, the change increasing as the conductivity and the *dielectric constant* of the ground decrease.²²¹ The rule given in Art. 138a for the construction of the field then no longer applies at all. The appearance of the field in the vicinity of the trans-

* Specific conductivity = 5×10^{-11} c.g.s. units. The amplitude, A , at a depth Z , is of the form $A = A_0 e^{-\sigma Z}$ (A_0 = amplitude at the surface).

† For qualitative consideration the specific conductivity, σ and dielectric constant, k , may be assumed to be as follows:²²³

Sea water	$\sigma = 1 \text{ to } 5 \times 10^{-11}$ c.g.s. units	$k = 80$
Fresh water	$= 10^{-14}$ c.g.s. units	$= 80$
Wet earth	$= 10^{-13}$ to 10^{-14} c.g.s. units	$= 5 \text{ to } 15$
Dry earth	$= 10^{-15}$ c.g.s. units	$= 2 \text{ to } 6$

mitter is not known. Nor do the statements made in Art. 138c hold good for *great distances* from the transmitting antenna.

Instead the facts, according to A. SOMMERFELD'S²²² theory, are as follows:

a. Surface and Space Waves.—The waves which emanate from a transmitter placed in a homogeneous insulating material were discussed in Art. 20. They are characterized by the fact that energy is radiated in straight lines, radially from the transmitter.* Consequently, the energy varies as $\frac{1}{r^2}$ (r = distance from source) and the amplitudes of the electric and magnetic field strengths vary as $\frac{1}{r}$. We will refer to these as “space waves” in what follows.

A different kind of wave is obtained, *e.g.*, with LECHER'S system [Art. 72c]. Here the waves travel along the wires, following any bends they may have. The flow of energy along the wires and the amplitude of the waves would remain constant during their progress, were it not for the fact that a portion of the energy is consumed in the wires (due to Joulean heat developed). This causes a gradual reduction in the energy and wave amplitude along the course of travel, a phenomenon which is termed “absorption.” We will refer to waves of this kind as “surface waves,” as they follow the surface of the conductor.

*b. The wave emanated into the air by an antenna at the earth's surface may be conceived as consisting of two component parts, one of which is of the nature of a space wave, the other of a surface wave.*²²⁴ In the former the energy $\propto \frac{1}{r^2}$, the amplitude therefore $\propto \frac{1}{r}$; in the latter the energy $\propto \frac{1}{r}$, the amplitude $\propto \frac{1}{\sqrt{r}}$. The fact that in the latter there is a decrease in the energy as the distance increases, in contrast to the wave following a wire—and in addition to and entirely aside from such absorption as occurs—is explained by the fact that the energy is spreading itself out over ever-increasing circles, as the wave travels its course.

Absorption of course occurs in addition to this reduction in amplitude due to the expansion of the wave in space. As each wave advances through the air it is accompanied by a wave in the ground. And as the ground always has more or less conductivity, the moving electric field, constituting the wave, results in the formation of currents, just as in the wires of the LECHER system. These currents consume energy, which is drawn from that of the waves radiated by the antenna, so that an absorption occurs in this way.

c. While at short distances from the transmitter, the waves are al-

* The direction of the flow of energy is, as already stated previously, perpendicular to both the electric and magnetic field directions.

most entirely of the nature of space waves, as the distance increases the surface component becomes more and more predominant, as its amplitude decreases more slowly than that of the surface component. That is, *the nature of the wave constantly approaches that of a surface wave.**

This change is the more rapid, the shorter the wave-length is and the lower the conductivity and dielectric constant of the ground are. A calculation of the distance at which the actual amplitude of the wave differs by 10 per cent. from the amplitude of the space wave, results in the following figures:

Sea water†	$\lambda = 2$ km.	Distance = 20,000 km. approx.
Sea water	$\lambda = 1$ km.	Distance = 5000 km. approx.
Sea water	$\lambda = 0.3$ km.	Distance = 500 km. approx.
Fresh water†	$\lambda = 2$ km.	Distance = 4 km. approx.

The distance becomes still shorter with dry ground.

Hence, while with sea water for all distances which come into consideration—20,000 km. is half the circumference of the earth—and for all wave-lengths over 1 km. the waves have the characteristics of space waves,‡ with fresh water and even far more so with dry ground, they assume the characteristics of surface waves at distances of only a few wave-lengths or even less than one wave-length. Hence the nature of the wave propagation in this case must not be conceived as being the same as that described in Art. 138 over sea water.

d. The subdivision of the wave into a space wave and a surface wave and a wave within the ground [b] makes it possible to give a simple description of the phenomenon. Physically, there is of course only *one single* wave extant, which travels partly through the air, partly through the ground along its upper surface.

The appearance of the electric lines of force of this wave in air at a given instant and a distance of 30 to 30.5 wave-lengths from the transmitter is shown diagrammatically in Figs. 297 and 298, which are taken from an article by P. EPSTEIN,²²⁵ the assumption being that the wave-length is 2 km. and that the conductivity of the upper stratum of the

* When the distance becomes *very* great, the surface wave may again give way to the space wave, as the former is more rapidly absorbed. It is questionable, however, whether this effect is of practical importance.

† On the assumption that $\sigma = 10^{-11}$ c.g.s. units for sea water and 10^{-14} c.g.s. units for fresh water.

‡ Herein lies the justification for the statements in Art. 138. The electric and magnetic field strengths in this case, taking consideration of the absorption, are given by [Art. 138c]:

$$E_0 = 4\pi \frac{\alpha h}{\lambda} \cdot |I_0| \frac{e^{-\beta r}}{r} \cdot 3 \times 10^{10} \text{ c.g.s. units}$$

$$M_0 = 4\pi \frac{\alpha h}{\lambda} \cdot |I_0| \frac{e^{-\beta r}}{r} \text{ c.g.s. units}$$

in which β is the coefficient of absorption.

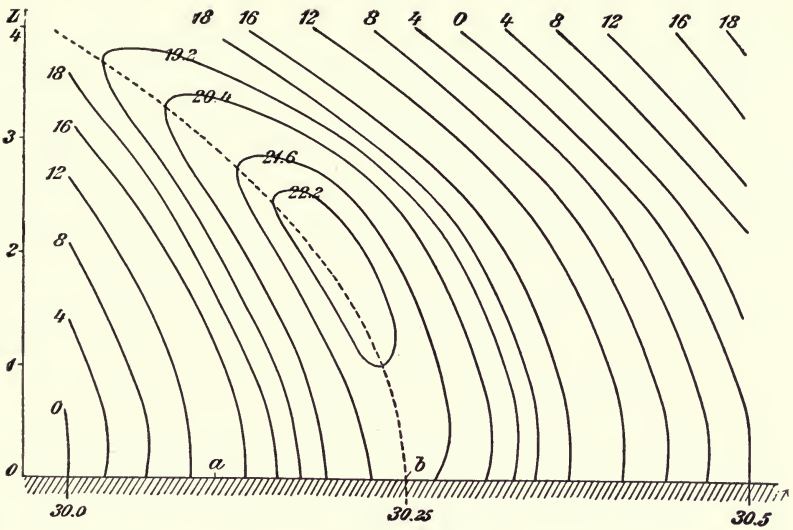

FIG. 297.

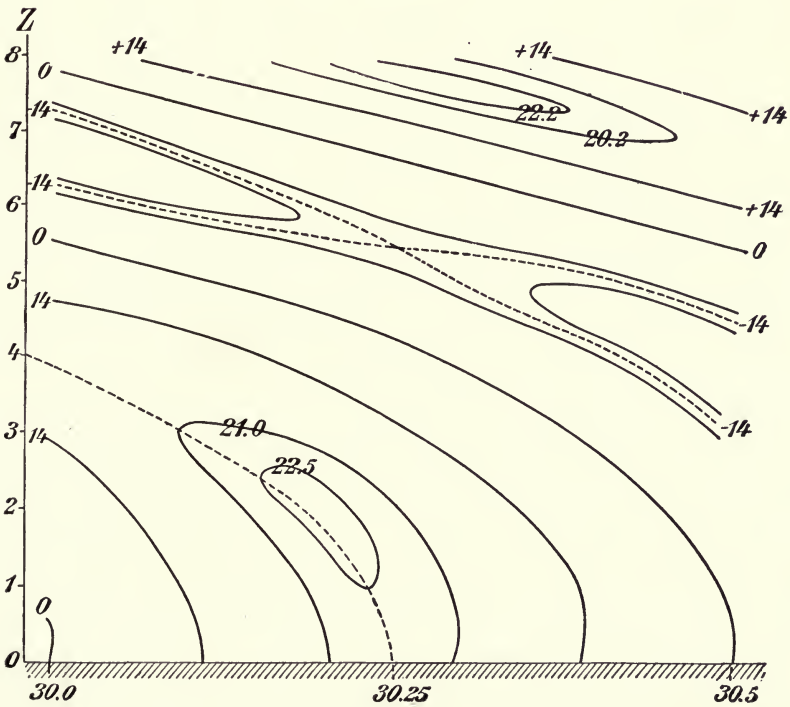

FIG. 298.

ground is about midway between that of sea water and wet ground. The scale of the ordinates (heights above ground) is one-twelfth of that of the abscissæ (distances from transmitter) in these figures.

By way of comparison, Fig. 299 represents the lines of force which would correspond to an infinitely great conductivity of the ground, according to Art. 138, the same scale and distance being used as in the preceding figures. It will be noted that there is no very great difference between Fig. 299 and the other Figs. 297 and 298; the latter, however, are based on the assumption of relatively high ground conductivity. With dry ground the differences would be much more marked.

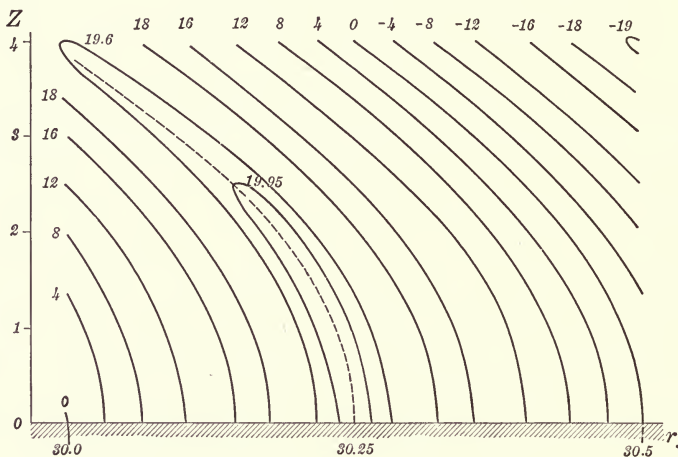

FIG. 299.

e. The nature of the field of the wave immediately above the earth's surface at very great distances from the transmitter, is of special practical interest. If the earth's surface were as good a conductor as a metal, then [Art. 138]

1. The electric field would be exactly perpendicular, the magnetic field parallel to the earth's surface, and
2. Both would be in phase [Art. 137].

As a matter of fact these conditions are approximately true over sea water, but they do not hold for fresh water or dry ground (J. ZENNECK²²).

However, the direction of the magnetic lines of force remains parallel to the earth's surface, but the electric field instead of being perpendicular to the earth's surface tends to follow the direction of travel of the wave.* Hence to the component, E_z , of the electric field strength perpendicular to the earth's surface there comes an additional component, E_x , in the

* This is already noticeable in Figs. 297 and 298, even though not very prominent, as the conductivity and wave-length were assumed to be relatively high for these figures.

direction parallel to the earth's surface. The ratio between the amplitudes of these two components is shown by the full line curves of Fig. 300 for different values of the conductivity and the dielectric constant,* under the assumption that the distance from the transmitter is so great that the waves may be considered not merely as surface waves, but as plane waves. From the curves it is evident that when the dielectric constant is small, the horizontal component can assume quite large proportions.

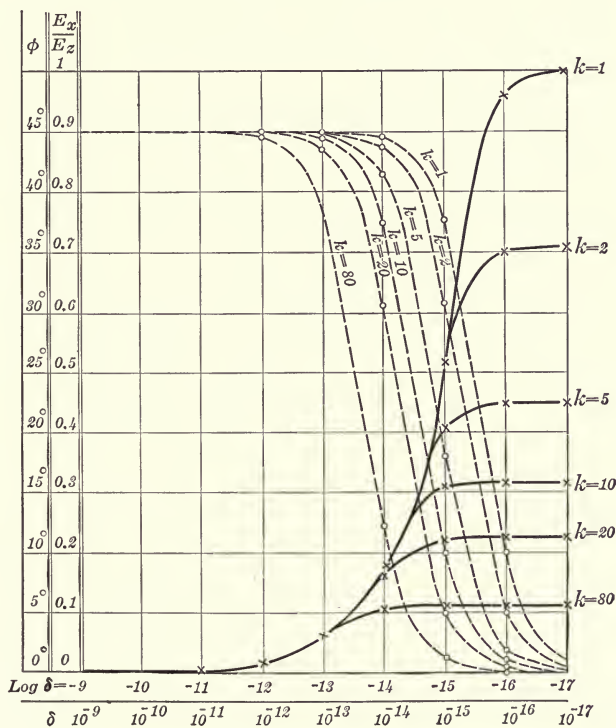

FIG. 300.

In this case, while the magnetic field and the vertical component of the electric field are approximately in phase with each other, there is a phase difference, ϕ , between the horizontal and vertical components of the electric field strength. The variation of this phase difference is shown by the dotted curves of Fig. 300, under the same assumptions made for the full line curves.

The result is that the electric field is no longer a pure alternating field but possesses a more or less large *rotating field component*.

A comprehensive picture of the field can be obtained by the familiar method of representing the resultant field strength by means of a vector.

* $N = 5 \times 10^5$ cycles per sec., $\lambda =$ approx. 670 m.

The locus of the end of the vector during one cycle is then an ellipse, of which (see Fig. 301).

$$\frac{\overline{OB}}{\overline{OA}} = \frac{E_{x_0}}{E_{z_0}}, \quad \frac{\overline{OA_1}}{\overline{OA}} = \frac{\overline{OB_1}}{\overline{OB}} = \sin \varphi$$

For the typical cases of low ground conductivity, the curves representing the field in the air acquire the form of Fig. 302* or Fig. 303.†

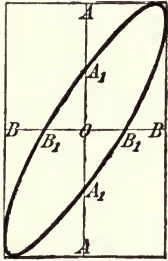

FIG. 301.

While the field over sea water, according to Art. 138c, is practically a pure vertical alternating field, over dry ground the field is greatly inclined at an angle to the vertical and has a more or less prominent rotating component.²²¹

f. The falling off in amplitude during the progress of the waves, depends upon the conductivity and dielectric constant of the ground and to a particularly great extent upon the wave-length. The greater the conductivity and dielectric constant of the earth, the slower is the falling off in amplitude, other things being equal; hence it is slow over sea water, very rapid over dry ground. The relation to the wave-length is such that the distance at which the amplitude has fallen to a given fraction of its value in the immediate vicinity of the transmitter $\propto \frac{1}{\lambda^2}$ over ground of very good

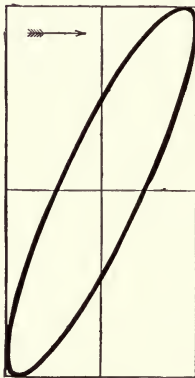

FIG. 302.

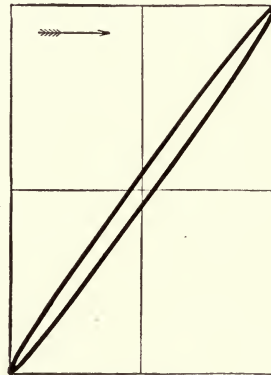

FIG. 303.

conductivity (sea water) and approximately $\propto \frac{1}{\lambda}$ over dry ground of very low conductivity.

This relation to the wave-length is very clearly illustrated by the curves of Fig. 304, in which the falling off of the amplitude along the length of a quadrant of the earth's circumference is shown, the ordinates

* Assumption $N = 5 \times 10^5$ cycles per sec., $k = 2$, $\sigma = 10^{-15}$ c.g.s. units.

† Assumption $N = 5 \times 10^5$ cycles per sec., $k = 2$, $\sigma = 10^{-16}$ c.g.s. units.

being the products of the amplitudes and their respective distances from the transmitter.

From what has preceded the following practical conclusions may be drawn:

1. *Great wave-length is far more advantageous for the propagation of the waves than short wave-length.** Thus in telegraphing across the sea, the same reduction in amplitude occurs at a distance twenty-five times as great with a 5 km. wave as with a 1 km. wave.

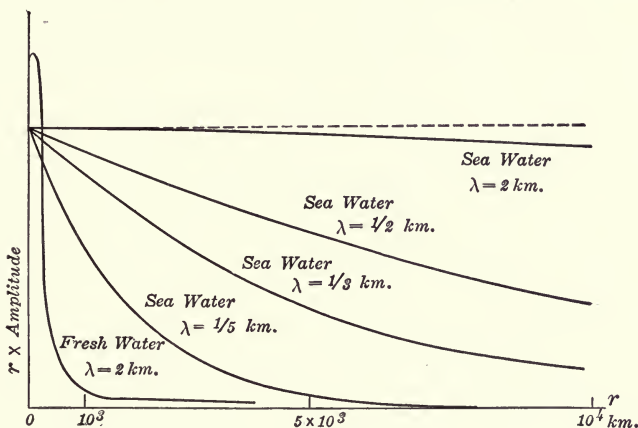

FIG. 304.

2. The falling off in amplitude is much greater over land than over sea for the same distance, the difference becoming more marked as the wave length²²⁶ employed becomes shorter. Hence, if waves are traveling partly over land and partly over sea, then only a few miles over land may cause the same reduction in amplitude as several hundred miles over sea. Hence, where large distances over sea are to be bridged (as in transatlantic work, ship-and-shore work), it is of the greatest importance to erect the shore stations as near the water as possible.†

g. The *velocity of propagation* of the waves as measured along the earth's surface may be somewhat greater than the velocity of light, 3×10^{10} cm. per sec. = 300,000 km. per sec., but, just as over sea water, the difference is never great.²²¹

140. Effect of the Spherical Shape of the Earth.—(H. POINCARÉ, J. W. NICHOLSON).—The various relations brought out in Arts. 138 and 139, rested on the assumption that the conductor (the earth), upon which the transmitter stands, has a plane surface. Consequently they hold

* So far as the influence of the earth's surface is concerned. The effect of the atmosphere [Art. 145] is not taken into consideration here.

† In this respect the high-power stations at Clifden and Glace Bay, also the Norddeich station are well located, while the Eiffel Tower and Nauen Stations are relatively at a disadvantage.

approximately for such distances in which the earth's surface may be considered as practically plane, but no longer apply to transatlantic stations, for which distances of about one-eighth the earth's circumference are involved.

How these relations change because of the spherical form of the earth has been theoretically considered by the authors named above, for the ideal case of extremely high conductivity of the earth's surface. H. W. MARCH²²⁶ has come to the same conclusions in a simpler way.

These results may be generalized under the statement that the earth's curvature affects the conditions which would exist over the previously assumed plane surface in two ways, viz.,

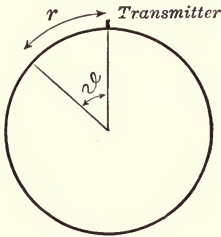

FIG. 305.

1. In that the energy propagation along the curved surface is different than along a plane surface.

2. In that the radiated or propagated energy does not entirely follow the course of the earth's curvature, or to express this differently, in that there takes place in addition to the propagation along the earth's surface, a radiation or "straying" of some of the energy into space away from the earth's surface.

a. Let us first consider the *propagation along the earth's curvature* entirely aside from the "stray" energy. The nature of this propagation is such that instead of the amplitude varying as $\frac{1}{r}$, as was the case with a plane, highly conducting surface [Art. 138c], the amplitude in this case

$$\propto \frac{1}{r} \sqrt{\frac{\vartheta}{\sin \vartheta}}$$

in which r is the distance from the transmitter measured along the earth's curvature and ϑ the angle at the center of the earth enclosing the arc whose length is r (Fig. 305).

This variation in amplitude is shown by the full line curve of Fig. 306, for distances up to half the earth's circumference ($\vartheta = 0^\circ$ to 180°), the dotted curve showing the falling off in amplitude when this varies as $\frac{1}{r}$, i.e., for a plane, highly conductive ground. Hence, if there were no stray field, the amplitude would decrease less rapidly over the spherical earth's surface than in the case of the flat surface. The difference, however, is not very great for distances up to a quadrant of the earth's circumference, and at half a quadrant amounts to only 5.4 per cent.

The fact that the amplitude decreases less rapidly in this case than over a plane surface, that, in fact, if there were no straying, it would begin to increase again after a considerable distance from the transmitter, can be accounted for by a consideration of the geometric distribution of

the flow of energy along the earth's surface.* Its course is along the meridians drawn through the transmitter, while in the case of the flat surface it is along the radii in its plane and passing through the base of the antenna. The latter continue to diverge at a constant angle as the distance increases, so that the energy is spread out over a constantly increasing area. With the spherical surface, however, the meridian circles diverge only between the values $\vartheta = 0^\circ$ and $\vartheta = 90^\circ$, *i.e.*, over the

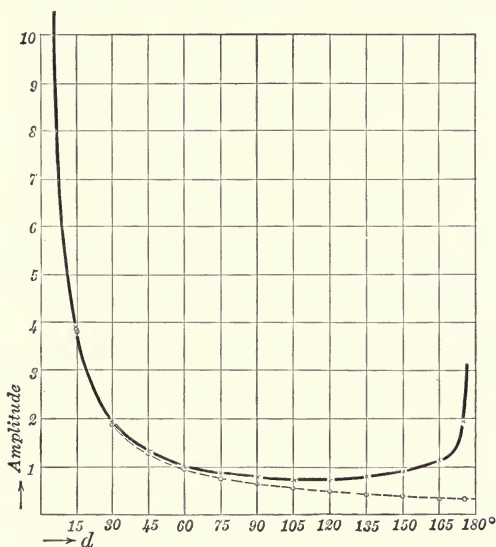

FIG. 306.

length of one quadrant. Moreover, even within these limits the angle of divergence grows constantly smaller as the distance increases; hence the area over which the energy spreads does not increase as rapidly as in the case of the plane surface. As the distance is further increased, from $\vartheta = 90^\circ$ to $\vartheta = 180^\circ$, the meridians converge until they again intersect at a point diametrically opposite the antenna; so that here we have a gradual concentration of the flow of energy as the opposite pole is approached.

b. In view of the *straying of energy* the expression given in *a* is incomplete without the so-called *stray energy factor*, which has been theoretically shown to be equal to

$$e^{-0.36 \cdot \vartheta \cdot \sqrt[3]{\frac{2\pi a}{\lambda}}} = e^{-0.0019 \cdot \frac{r}{\sqrt[3]{\lambda}}} \quad (r \text{ and } \lambda \text{ in km.})$$

* This alone, however, does not determine the reduction in amplitude with increasing distance, but rather the flow of energy through the entire space.

† a = radius of the earth. The factor $0.0019 \cdot \frac{1}{\sqrt[3]{\lambda}}$ might be termed the "*stray energy coefficient*."

so that the equation for the variation in the amplitude, A , over the curved surface of the earth having infinitely great conductivity and surrounded by a homogeneous absolutely non-conducting atmosphere [Art. 145] becomes

$$A = A_0 \cdot \frac{1}{r} \cdot \sqrt{\frac{\vartheta}{\sin \vartheta}} \cdot e^{-0.0019 \cdot \frac{r}{\sqrt{\lambda}}} \quad (1)$$

Thus, e.g., for $r = \frac{1}{2}$ earth's quadrant and $\lambda = 4$ km., the stray energy factor becomes $\frac{1}{400}$.

c. A comparison of this equation with that deduced by L. W. AUSTIN [Art. 146b] from his daylight measurements, shows that the results obtained by the two methods do not differ very greatly, both as to the quantitative value of the stray energy factor and as to the relation of this factor to the wave-length.

Moreover, a comparison of *Austin's actual observations* with the theoretical equation (1) leads to the conclusion that these observations are reproduced just as closely by the theoretical equation as by his empirical formula.

At the same time it must be remembered that the theory involved has not yet been completed. It has been developed only under the assumption that the earth's surface has infinitely great conductivity. It remains to be seen whether a completed theory, taking consideration of the finite conductivity of the earth's surface and therefore involving a reduction in amplitude due to absorption, will be in equal accord with test observations.

2. WAVE PROPAGATION OVER UNEVEN OR NON-HOMOGENEOUS GROUND

In **1** it was assumed that the portion of the earth's surface over which the waves pass consisted of homogeneous material and that the surface was a smooth plane or sphere. There remains to be investigated what changes occur if:

1. The earth's surface is considerably uneven.
2. Underneath the surface there are strata of widely varying conductivity and dielectric constants.
3. The earth's surface has portions varying greatly in their conductivity and dielectric constants.

141. Uneven Surfaces.—The waves in their course may encounter obstacles in the form of hills or mountains and trees or buildings.

a. With *hills or mountains*, three possible cases can be distinguished, viz.,

1. The wave passes through the hill (Fig. 307);
2. It glides over the contour of the hill (Fig. 308); or
3. The waves bend down over the peak of the hill to reach the farther side (Fig. 309).

Just what takes place in any individual case depends upon the form of the hill and the conductivity and dielectric constant of its material. Bending probably occurs in all cases. That it, in fact, frequently plays the main part follows from the observations of H. B. JACKSON²²⁷ who found that a ship lying just alongside of a hill could not receive the

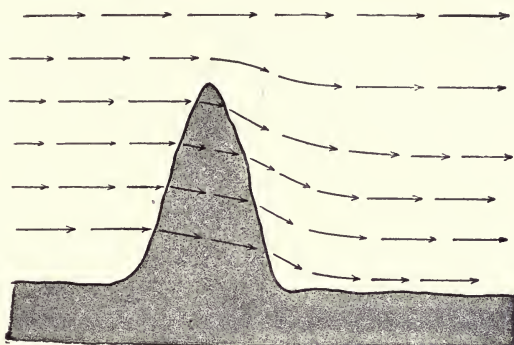

FIG. 307.

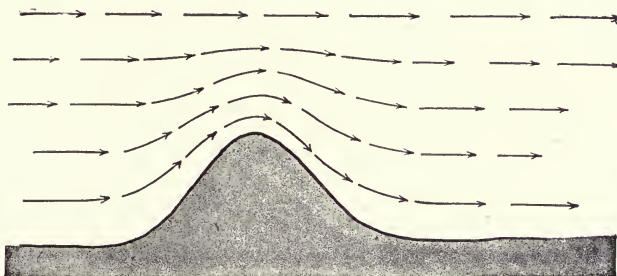

FIG. 308.

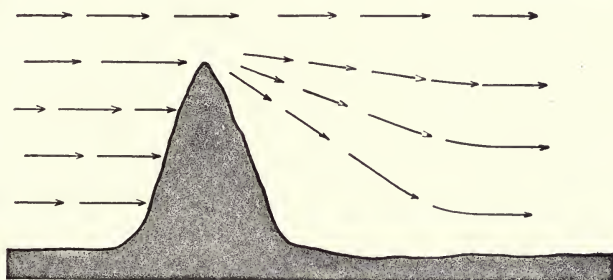

FIG. 309.

messages sent from a station located on the other side of the hill, but did receive them as soon as it had passed somewhat further away from the hill. If the hill in the path of the waves consists of material of relatively good conductivity and its width is very great compared to the wave-length, the result will probably be mainly as described in case

2. The portion of the wave passing through the hill (case 1) can only be of consequence when the material of the hill has *very* low conductivity (rocks) and the hill is not very wide.

In all cases the hill will decrease the amplitude of that portion of the wave which passes through or over it, that is, the hill will, so to say, throw an electromagnetic shadow, which will be more marked the shorter the wave-length is.*

This has been observed, *e.g.*, in tests between Nauen and ships on the Atlantic in which the "shadow" of the mountains of Spain was distinctly evident. In practice the range of portable sets in mountainous country is usually assumed to be only 50 per cent. of the normal range on flat or only slightly hilly country.

b. DUDELL AND TAYLOR²²⁸ have demonstrated that groups of trees may very greatly interfere with the distribution of short waves. Densely wooded regions are particularly unfavorable to the propagation of short waves and it is usually estimated that they will reduce the range of portable stations by 50 per cent. Similarly high buildings or other structures, especially if they are in the immediate vicinity of the transmitter or receiver, are apt to be a great hindrance. In both cases, no doubt, it is a question of the effect of induced currents.

142. Rain and Ground Water (F. HACK²²⁹).—*a.* The case previously mentioned in which the ground consists of layers having very different properties closely following each other, exists when the upper layer of a portion of ground which has very low conductivity and low dielectric constant, becomes highly conductive and has a high dielectric constant due to a rain or snow fall of long duration. This case has been previously treated only on the assumption that the distance from the transmitter was very great, so that the waves could be considered not merely as surface waves, but also as plane waves.

The *direction* of the electric field at the earth's surface under this assumption is shown in Figs. 310 to 312.† The first represents the field [see Art. 39e] for entirely dry ground, the second and third represent the case of the ground being wet to a depth of 20 and 40 cm. respectively. From these figures it is evident that the large rotating field component which is present when the ground is quite dry, becomes more and more

* MARCONI¹⁹¹ has stated that the weakening of the waves by hills or mountains, if the waves are relatively short, occurs only in daylight, and never at night.

† Thanks are due PROF. DR. F. HACK of Stuttgart for the Figs. 310 to 317. They are based on the assumptions that:

For dry ground,	$\sigma =$	10^{-16} c.g.s.,	$k = 2$
For wet ground	$\sigma =$	10^{-13} c.g.s.,	$k = 15$
For ground water,	$\sigma = 5 \times 10^{-14}$	c.g.s.,	$k = 80$

The curve drawn in the shaded area represents the electric field in the part of the ground under consideration.

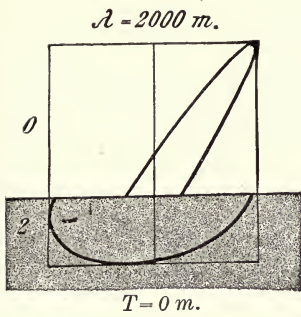

FIG. 310.

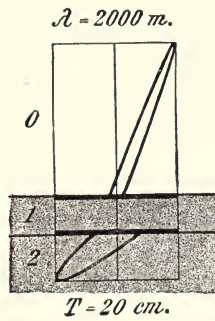

FIG. 311.

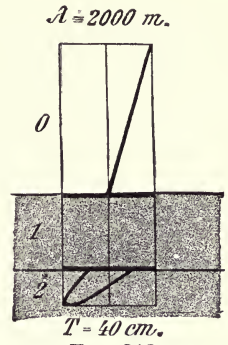

FIG. 312.

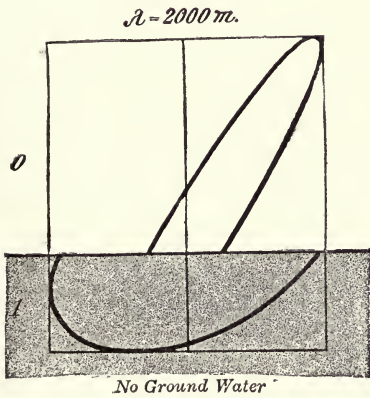

FIG. 313.

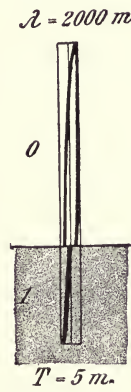

FIG. 314.

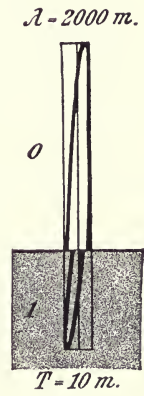

FIG. 315.

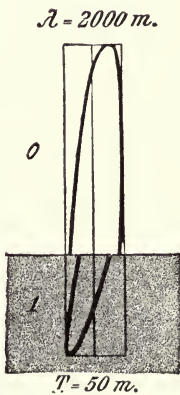

FIG. 316.

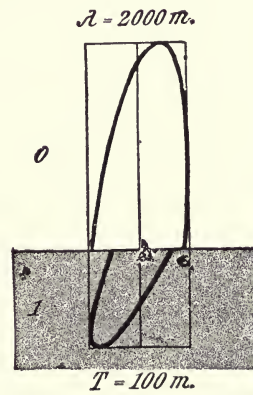

FIG. 317.

reduced so that the field approaches a pure alternating field, as the wet layer of the soil increases in depth.

The *absorption* of the waves is also affected by rain; the deeper the rain soaks into the ground the more the absorption is decreased.

b. In most localities, the upper layer of dry soil and stones has a stratum of *ground water* at a depth of from just a few to about 100 m. below the surface.

Figs. 313 to 317, drawn under the same assumptions which Figs. 310 and 312 were based upon, illustrate the field at the earth's surface for a wave-length of 2000 m. for various distances, T , of the ground water below the surface. In all cases the ground water is assumed to extend to a very great depth. It will be seen that the effect of the ground water is to bring the direction of the electric field more nearly vertical to the surface of the earth. The *absorption* may be either increased or decreased, but in most practical cases where the wave-length is greater than 1 km. it is reduced.

143. Distribution Over Land and Water.—If there are both land and water, particularly sea water between two stations, various effects may occur.

a. The main portion of the wave may be *guided* by the stretch of *sea water*, following this rather than a shorter land route, *e.g.*, it is not impossible that when English coast stations transmit to ships in the Mediterranean Sea, a portion of the waves reaching the ships, instead of taking the direct path across the Alps, pass entirely over sea, by way of Gibraltar.*

Even *rivers* seem to have a similar effect. At any rate in tests made on moving trains it was found that the intensity of the signals received always greatly increased when the train approached a river.²³⁰ Hence it would seem that the waves tend mainly to follow the better conducting water paths.

Moreover, in tests with such receiving antennæ as determine the direction of the incoming waves [Art. 207*b*], it was noticed that the direction did not always correspond with that of the transmitter.²³¹ The waves in such cases, evidently under the influence of the variations in the ground, did not proceed in straight lines over the surface of the earth.

b. In passing from water to land and *vice versa*† a partial *reflection*

* This would not explain the fact, observed by MARCONI¹⁹¹ that ships in the Mediterranean could telegraph most conveniently with English land stations at night ($\lambda = 300$ or 600 m.), at distances over 1000 miles, but that ships in the North Atlantic Ocean can very rarely be reached at the same distances, though no land intervenes here. [Translator's Note.—Similar observations have been made on the American coast and from many reports it would appear that usually longer distances can be attained in a north and south than in an east and west direction.]

† Or expressed in more general terms—in passing between portions of the earth's surface having different electric properties.

and possibly also refraction or bending of the waves must occur.²²² Hence the amplitude of the waves received from a given transmitter at a given distance depends not merely upon the distance traveled over land and over sea, but also upon the *shape of the coast** encountered by the advancing waves.

Perhaps this accounts for the fact that at times certain points at a much greater distance from the transmitter receive its signals much louder than points nearer to it. In many such cases, however, the explanation may lie in the possible interference between two trains of waves which have reached the point of reception by different paths and are therefore out of phase with each other.

3. EFFECT OF ATMOSPHERIC AND OTHER INFLUENCES UPON THE WAVES

144. Effect of the Condition of the Atmosphere.—*a.* The entire theory discussed in what has preceded does not entirely represent the actual conditions; it was based upon the assumption that the earth, itself a conductor, is surrounded by a perfect insulating and homogeneous medium. However, the properties of the atmosphere undoubtedly vary at different heights and furthermore the air is not a perfect insulator. These conditions must be factors in determining the propagation of the waves.

b. The *absorption* of the waves may depend upon the condition of the atmosphere. Moreover the *direction* and the *form* of the waves may be changed if there are a number of layers of the atmosphere, having different qualities, spread over the surface of the earth. Finally, any *heterogeneity* of the atmosphere may cause dispersion, refraction or partial reflection.

The similar phenomena which occur when rays of light pass through the atmosphere have often been used as analogies.²²³ This is justified within certain limits, but the wide difference between the two cases must not be forgotten. Thus, the wave-length used in radio-telegraphy for the longer distances is from 1000 to 6000 m. Any heterogeneity in the atmosphere extending over one or more kilometers is, therefore, already of the same order of size as the wave-length; the conditions are then comparable to those encountered in optics in colloidal solutions. Furthermore, not merely the condition of the atmosphere, but also the proximity to the earth's surface in a given case determines the nature of the propagation of electromagnetic waves, wherein another difference exists as compared to light waves.

c. There is no doubt at all that atmospheric conditions greatly influence the range of a station. But we must make the following distinction:

* Thus a circular bay might perhaps act similarly to a concave mirror.

1. The *direct* effect, which the condition of the air (ionization, humidity, atmospheric pressure and temperature) may have upon the wave propagation.

2. The *indirect* effect which may consist, on the one hand, of changes in the insulation and ground resistance in the vicinity of the transmitting antenna and hence in the oscillations radiated; on the other hand changes in the earth's surface between transmitter and receiver affecting the absorption of the waves.²³⁴

Accordingly, experiments in which these indirect effects were not avoided or at least were not under exact control, are of no use in determining the direct effects. This immediately eliminates all tests over land, as it is impossible to avoid or quantitatively determine the effect of the weather upon the stretch of the earth's surface in question. Only tests over sea, and preferably from ship to ship should be considered, and even these only if it is definitely determined that the insulation of the antenna, and hence the oscillations, were not affected.

In spite of all such precautions, the greatest care is necessary in drawing conclusions from the results obtained. If the atmospheric conditions really do influence the wave propagation, then the entire zone of space between transmitter and receiver must be taken into consideration, something hardly possible in most such tests over great distances.

145. Ionization of the Atmosphere.—In previous articles the air was assumed to be a perfect insulator. However, the air is always somewhat ionized, due to radio-active emanations from the ground, to the action of the sun's ultra-violet rays and probably also to electrons sent out from the incandescent sun.*

a. The *conductivity* of the atmosphere, due to this ionization, up to heights accessible by means of balloons (about 6000 m.) is *very low*, much lower in fact than that of the driest ground. Such slight conductivity can hardly have an appreciable influence upon the form of the waves; their absorption is probably increased by it, but only very slightly.²²¹

However, even at heights attainable in balloons it is noticeable that the ionization of the air increases with great rapidity as the height increases. It is very probable that it assumes large proportions at *very* great heights, for at such altitudes the action of the ultra-violet rays of the sun and probably of the action of the electrons emanating from the sun must be much more powerful than at the lower layers of air, where both are already almost entirely absorbed.

There are then two possibilities. Either the conductivity of the air even at the greatest altitudes in question, is still *very* small as compared to, say, the conductivity of wet ground; in which case the effect of

* It has been reported²³⁶ that the *polar lights* have a marked effect upon the transmission between a station in Spitzbergen and one in Hammerfest.

the upper layers of the atmosphere will consist mainly in increased absorption of the waves. Or the conductivity of the uppermost layers of the atmosphere is of about the same order as that of wet ground; in which case the conditions would be quite different than has been assumed in Art. 138 *et seq.* We then would not have a practically homogeneous medium of infinitesimal conductivity surrounding the earth, but rather *three* concentric layers, viz., the earth's crust or outer layer of relatively good conductivity, then the lower portion of the atmosphere of infinitesimal conductivity and, finally, the upper layers of the atmosphere of good conductivity,^{226a} the transition between the latter two being more or less gradual. In this case, the waves radiated by a transmitter at the earth's surface would find two guiding conductive layers and would progress in the space between them. The form of the waves, moreover, might become quite different than that which results under the assumptions of Arts. 138 and 139. No general conclusion can be drawn as to the effect of the upper layers of the atmosphere upon the absorption, as this might be either increased or decreased according to the conductivity of the upper layers of the air.

b. J. A. FLEMING²³⁷ considers an *indirect* effect of the atmospheric ionization. He assumes that in the upper ionized regions of the atmosphere, water vapor condenses on the ions thereby increasing the *dielectric constants* of these layers and so reducing the velocity of the wave propagation. The result of this would have to be a bending backward of the wave front advancing over the earth's surface and the *direction of the radiation would thereby be turned upward.*

c. If such extensive ionization of the air as to materially affect the waves, either directly or indirectly is at all possible, then it must be kept in mind that vertical air currents, clouds, fog, etc., would cause wide variations in the conductivity at different parts of the same layer of air at the same height. Such lack of homogeneity might furthermore cause dispersion, reflection, absorption, etc., of the waves and possibly also lead to interference phenomena.²³⁸

d. The first *observation* which indicated an effect of atmospheric ionization, was that made by MARCONI,²³⁹ which has since then been repeated again and again, namely, it is found that in telegraphing over great distances, but with not very great wave-lengths ($\lambda < 4000$ m.), *the same transmitter is apt to be much more effective at night than in daylight.* The distance reached at night is at times two and one-half times that reached in the daytime, according to MARCONI. The quantitative measurements of L. W. AUSTIN* confirm a daylight effect and agree with MARCONI'S observations inasmuch as *the action or intensity is very nearly constant in the daytime, but very irregular at night, sometimes being only slightly greater, then again very much greater, than in the day.**

* AUSTIN'S observations [Art. 146b] were made with wave-lengths up to 3750 m.

In addition there have recently been made numerous observations indicating that during an *eclipse of the sun* the intensity of wireless signals increased as the sun was darkened and decreased again with increasing sunlight.²⁴⁰

These observations, so far as reduced daylight intensity is concerned, would be explained by the increased ionization of the upper layers of the atmosphere in the daytime. Nor would MARCONI'S observation that the difference between day and night practically disappears with wave-lengths of 6000–8000 m. interfere with this explanation; for it might well be that the direct [*a*] or the indirect [*b*] effect of atmospheric ionization, as well as the effect of the conducting earth, is not so great for long as for short waves. But as regards MARCONI'S statement that with an 8000 m. wave the range is *greater* in the day than at night, it will be necessary to substantiate this with observations of a further *regular* increase in range in the daytime with additional increases in wave-length, before drawing any final conclusions.

It will be difficult, with our present knowledge of the conditions involved, to find a sound explanation for the observation that the intensity of signals *greatly fluctuates at night*.* This observation makes the generally accepted theory that the night action is the normal one, corresponding to an unionized atmosphere, while the daytime action is weakened directly or indirectly by ionization, appear somewhat doubtful. At any rate, it is possible to conceive that it is the daytime action which is "normal" and that at night the intensity is increased by causes as yet not definitely understood. This last conception would be the only possible one, if it is really found [Art. 140c] that the falling off in amplitude actually observed in the daytime is equal to that theoretically calculated as due *only to absorption* by the earth *and straying* due to the spherical form of the earth, without assuming any effect due to ionization or heterogeneity of the atmosphere.

Particularly complicated conditions occur at *sunrise* and *sunset*. They are best illustrated by curves given by MARCONI¹⁹¹ and reproduced in Fig. 318; the abscissæ represent Greenwich time in hours, the ordinates the intensity of the signals received in *Clifden* (Ireland) from *Glace Bay* (Canada), drawn to a convenient scale, the full line curve referring to $\lambda = 7000$ m., the dotted curve to $\lambda = 5000$ m. These curves indicate a very constant intensity during the day, but shortly after sunset in

* Nor have we any explanation worthy of serious consideration for MARCONI'S¹⁹¹ observation of the fact that the bad effect of land and mountainous country upon wave propagation with comparatively short waves exists in the daytime, but not at night.

To be sure it is not clear whether MARCONI'S statements are general or are intended to refer only to communication between England and Mediterranean points, in which latter case particularly complicated conditions seem to be involved (see foot-note to Art. 143a).

Clifden the intensity drops off, reaching a minimum about 2 hours later. From then on it rises rapidly to a very high maximum occurring about at the time of sunset in Glace Bay. Then the intensity gradually falls off and during the period when darkness covers the entire Atlantic

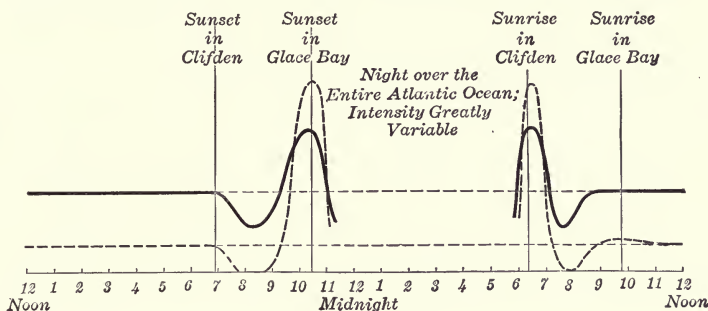

FIG. 318.

Ocean, it is extremely variable. Shortly before sunrise at Clifden the signals again gradually increase in intensity until they reach a maximum just after sunrise at Clifden. Then the intensity falls off again to a de-

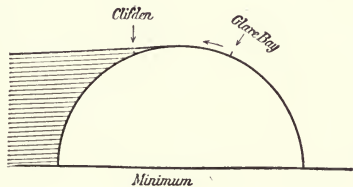

FIG. 319.

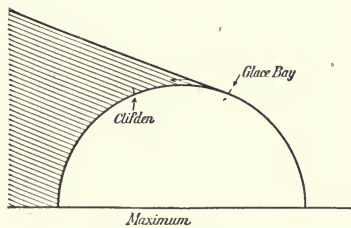

FIG. 320.

cidied minimum, which occurs an hour or two before sunrise at Glace Bay, after which it rises to the normal day value again.

In Figs. 319-322 the distribution of light and darkness (the latter

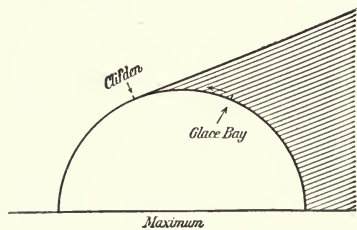

FIG. 321.

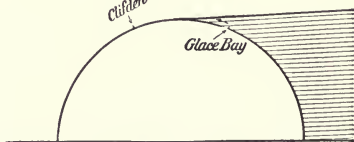

FIG. 322.

shaded) is sketched for the times at which the minimum and maximum intensities occur. From these it is apparent that MARCONI'S observations would find a ready explanation if the waves in the ionized region had a lower velocity of propagation than those in the unionized region and that,

in passing from the slightly to the greatly ionized* portion of the atmosphere and *vice versa*, considerable reflection† occurs.

The effect of the wave-length in this connection should be noted. While the intensity of the 5000 m. wave is considerably lower during the day than that of the 7000 m. wave, yet the shorter wave reaches a considerably higher maximum at the points of sunrise and sunset.

e. We have proceeded partly under the assumption that observed differences between night and day transmission involved an indirect effect of the daylight, viz., the light affected the brush discharge of the antenna and thereby the damping and amplitude of the oscillations.

This might occur in either of two ways. Thus, the photoelectric action of the light upon the upper surface of the antenna might increase the discharge from the antenna. This is made very improbable by the fact that the photoelectric action of daylight at the surface of the earth upon impure metallic (or copper) surfaces is very slight.

Otherwise the daylight, by increasing the conductivity of the air, might indirectly affect the brush discharge. At points where a brush discharge occurs at night, there is probably no appreciable change during the day, as the effect of the daylight is extremely small in comparison to that of the strong ionization caused by the antenna's electrical field. But it is conceivable that at such points of the antenna where the potential amplitude is not quite sufficient to cause a brush discharge during the night, the additional direct or indirect effect of daylight might produce a brush discharge.

Laboratory tests²⁴² with coils and simple aeri-als have shown no appreciable effect due to strong ultra-violet light; ‡ damping measurements on antennæ in our latitude did not give sufficient differences in the decrement between night and day as to explain the difference between night and day transmission.²⁴³ In the tropics, however, the day values have at times been found to be very much higher than the night values.

f. The following practical conclusions may be drawn from what has been stated in *d* as to the differences between day and night transmission:

* It is here not a question of whether a portion of the atmosphere is *light* or *dark*, as the lower layers of the atmosphere are always to be considered as slightly ionized whether in daylight or not. Thus Fig. 320, if the slightly ionized region were shaded, would appear, on a somewhat larger scale, as shown in Fig. 323.

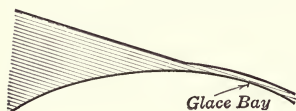

FIG. 323.

† Perhaps herein may also be found the explanation of MARCONI'S¹⁹¹ observation that the range at

night is greater in a north-south or south-north direction than in an east-west or west-east direction.

‡ MARCONI'S²³⁹ observation that the effect of daylight upon transmission becomes noticeable only at relatively great distances (say over 250 km.), also makes it very improbable that light affects the oscillations of a transmitter.

1. As waves of great length are considerably more advantageous in the daytime, but have no great increase in their action at night, while shorter waves, though weaker in the daytime, have their radius of action greatly increased at night, it would appear advisable to operate with relatively *longer waves in the daytime and with shorter waves at night*. This, in fact, is occasionally done in practice.

2. It is often stated as evidence of the range of a station that its signals have been clearly received at night by some other distant station. As night transmission is always irregular, only the negative conclusion that the two stations are not capable of regular and constant communication can be drawn with safety.

146. Actual Measurements of the Wave Propagation.—The theoretical results of Art. 138 *et seq.* were based upon the assumption of more or less ideal limiting cases. It is very important therefore to study the results of actual reliable tests.

a. Only such tests in which the conditions governing wave propagation in wireless telegraphy are duplicated should be considered. This eliminates:

1. All laboratory tests or tests made in the immediate vicinity of buildings, as reflection from the walls and disturbances due to conductors are apt to greatly modify the results, unless the work is done with very short waves [see exception 3 in this connection].

2. All tests in which the distance between transmitter and receiver is not considerably greater than one wave-length. In radio-telegraphy we deal almost entirely with the field at a great distance from the transmitter, which is apt to be quite different from the field near the transmitter, particularly as the falling off in amplitude obeys totally different laws at great distances than in the proximity of the transmitting aerial.

3. All tests in which the wave-length is much different from those used in radio-telegraphy; according to Art. 139, the wave-length is a factor in determining the form and absorption of the waves.

b. The early experiments of W. DUDDELL and J. E. TAYLOR²²⁸ have shown that over sea the amplitude—excepting in the immediate vicinity of the transmitter—varies approximately, as $\frac{1}{r}$. These tests were made over distances of from 16 to 60 miles. Similar tests by C. TISSOT²²⁸ gave the same results.

More recently, L. W. AUSTIN²⁴⁴ conducted very careful measurements involving *very long distances* (up to 1000 nautical miles), using the high power station at Brant Rock as transmitter and a receiver on board a U. S. battleship. He found that the reduction in amplitude is considerably more rapid than would correspond to $\propto \frac{1}{r}$ and also that it is less rapid for long than for short waves in the daytime.

Thus Fig. 324 represents the result of a series of observations. The ordinates are the values of the effective current in the receiver, which, other things remaining equal, is proportional to the amplitude of the electric field strength at the receiver. The dotted curve is plotted to show what occurs under the assumption—amplitude $\propto \frac{1}{r}$, *i.e.*, that there is neither any absorption [Art. 139] nor a stray field [Art. 140]. The actual observations are plotted as small crosses;* they are all below the dotted curve, the day observations following the full line curve fairly closely. This curve is calculated from an empirical equation which seems to correspond quite well with the observations.† This equation gives the value of the effective current in the receiver as equal to

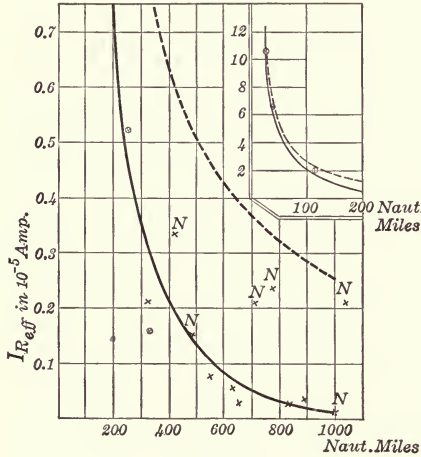

FIG. 324.

$$AI_{eff} \cdot \frac{h_1 h_2}{r\lambda} \cdot e^{-0.0015 \frac{r}{\lambda}}$$

where A is a constant, I_{eff} the effective current in the transmitter, h_1 and h_2 the heights of the transmitting and receiving antenna respectively, all lengths being expressed in kilometers.

c. In regard to propagation over *land*, the measurements of DUDDLELL, and TAYLOR²²³ already showed that at considerable distances from the transmitter the amplitude falls off more rapidly than the factor $\frac{1}{r}$.

L. W. AUSTIN²⁴⁵ in tests over 45 miles of land found that the absorption with $\lambda = 3750$ m., was hardly greater than over sea, but that with $\lambda = 1000$ m. it was much greater over land.

It seems evident from a great number of observations that the reduction in amplitude is largely dependent upon the nature of the ground involved, whether it is the different petrologic formations or differences in the moisture contained which are the determining factors, and that in general much moisture is favorable, dryness unfavorable to the wave propagation.

147. Effect of Grounding the Transmitter upon the Wave Propagation.—

* The crosses within a circle represent observations with a galvanometer and detector, the plain crosses those made with a telephone and detector [Art. 51]. The letter N over a cross indicates a night observation.

† h_1 and h_2 were varied from 12 to 43 m., I_{eff} from 7 to 30 amp., λ from 300 to 3750 m., r from 30 to 1000 nautical miles.

A study of the effect of grounding in radio-telegraphy must be subdivided under the following two questions:

1. What is the effect upon the oscillations (their frequency, distribution and amplitude of the current, damping)?

2. What is the effect upon the propagation of the waves?

The first question was discussed in Art. 99 *et seq.*, the second in Art. 138 *et seq.* From these, however, a third question suggests itself, *viz.*, have the extent and manner of grounding the transmitting antenna any effect upon the propagation of the waves?

With sea water such an effect would seem *a priori* very improbable; not so however with dry land. Certainly it is conceivable that extending or not extending the ground connection to the ground water would have a different effect not merely upon the ground resistance, but also upon the *propagation* of the waves.

If it is desired to answer this question with actual tests,* it is absolutely essential to prevent changes in the ground connection from affecting the antenna oscillations, *i.e.*, the frequency, damping, current amplitude and distribution must remain constant. Otherwise the tests will give no information. It is very doubtful that any reliable tests in which all such influences were entirely eliminated have ever been recorded.

148. The Safety Factor.—From Arts. 142 and 144 *et seq.*, it follows that the effect of a given transmitter upon a given receiver is influenced by various conditions, such as weather conditions. Hence, where it is required that communication between the given stations shall not simply stop whenever a combination of unfavorable conditions arises, it is necessary to introduce a considerable “**factor of safety.**” The “**range**” of the transmitter, *i.e.*, the distance at which the receiver is still just able to distinctly receive the signals, must be considerably greater than the distance between the two stations for maintaining uninterrupted communication.

The TELEFUNKEN Co. formerly used a safety factor of 3,²⁴⁶ *i.e.*, the range of its commercial stations had to be three times as great as the distance to be bridged in regular service.

* The literature of radio-telegraphy abounds with such tests.

CHAPTER XI

DETECTORS²⁴⁷

No *direct* detection of the electromagnetic waves emanating from a radio-transmitter is possible. We are limited to causing the waves to induce oscillations in the conductors of the receiver and to detect these oscillations by means of suitable apparatus. Hence the names “**wave indicators,**” “**detectors,**” etc., although these devices really indicate the oscillations in the circuits in which they are connected.

1. THERMAL DETECTORS

149. Bolometer and Thermogalvanometer.—The currents induced in radio-receivers, as soon as distances of any great extent are involved, are of very low amplitude. Hence if the heat developed by these currents

is to be used for their detection, only the more sensitive of the apparatus already described [Art. 4 *et seq.*], such as the bolometer, thermocouple and thermal galvanometer can come into consideration, and even then only for moderate distances.

The *bolometer* has been extensively used by C. TISSOT²⁴⁸ and others for radio-measurements. Its form was, in principle, that shown in Fig. 102, the bolometer wire being very fine and enclosed in a vacuum tube. Later the bridge connection was replaced by the compensation method of connection devised by BÉLA GÁTI.

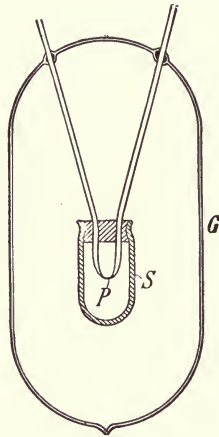

FIG. 325.

The wave indicator used by R. FESSENDEN and others under the name of “*solid barretter,*” consists essentially of a very fine platinum wire (so-called Wollaston wire) (*P* in Fig. 325) of 0.002 mm. diameter and 0.4 mm. long in a glass vessel (*G*, Fig. 325) containing a vacuum. To prevent a loss of heat by radiation, the wire is enclosed in a small container, *S*, of silvered glass. FESSENDEN did not, at least not in all cases, use this barretter in connection with a bridge, but placed it directly in a telephone circuit, so that the telephone responded to the current variations caused by the changes in the resistance of the wire.

The *thermal galvanometer* has proven itself well suited to measurements at moderate distances, and was used among others by W. DUDELL

and J. E. TAYLOR²²⁸ and also by MARCONI²⁴⁹ in his experiments with directional telegraphy.

150. Thermocouples.—Thermal Detectors.—The wave indicators whose action depends upon thermoelectric effects may be divided into three classes, as follows:

a. Thermocouples of *wires* [Art. 48]. Excellent as these are for laboratory purposes, they are hardly sensitive enough for general use as wave indicators, in spite of all precautions to minimize heat losses and the use of very short and thin wires.

*b. Thermal Detectors with Point Contacts.*²⁵⁰—The requirement for maximum sensitiveness in a thermocouple (thermal detector) would appear to be the production of the greatest *temperature rise* at the point of contact. Hence it is important that those parts of the thermocouple in which the heat is developed, aside from having the lowest possible specific heat, have as small a mass and surface as possible. With thermocouples made of wire this is obtained by the use of very fine wires (and the minimum of solder, where this is used). But another method is to have one of the elements of the thermocouple touch the other at a *point* or *knife-edge*.

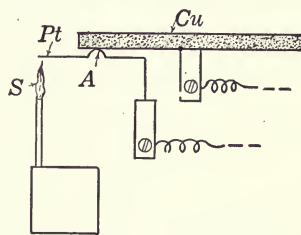

FIG. 326.

Thermal detectors of this type have been devised of numberless combinations, such as tellurium-aluminium (L. W. AUSTIN, NAT. ELEC. SIG. Co.), tellurium-galena (C. LORENZ), silicon-copper (G. H. PICKARD), tinfoil-galena (TELEFUNKEN Co.) and also the extensively used graphite-galena combination.*

The usual arrangement is to have one of the elements pressed against the other by means of a spring and to provide a fine adjustment for regulating the pressure.

In some forms one metal is disc-shaped and kept in constant rotation while the other brushes over it with a slight pressure (L. W. AUSTIN).

c. Thermal Detectors with Heating Device.†—An example of this type is found in W. SCHLÖMILCH'S (TELEFUNKEN Co.) thermal detector. In this, one element is a platinum wire with a small bend in it (A, Fig. 326), pressing lightly against a disc of oxidized copper. The platinum wire is heated by means of a small alcohol flame, so that a thermoelectric force exists at all times; the oscillations therefore simply vary, rather than create the thermoelectric force. This detector is no longer used in practice.

* With some of these detectors, however, it is not certain that the action is really thermoelectric [Art. 160c].

† See Art. 162a regarding the purpose of this heating device.

151. Relative Importance of the Thermal Detectors.—Most of the thermal wave indicators mentioned in what has preceded are preeminently adapted for certain *quantitative determinations* in radio-telegraphy. For some of these measurements, transmitter and receiver need only be separated by a few kilometers. But even where a distance of several hundred kilometers is necessary, some of the thermal detectors have sufficient sensitiveness to serve the purpose, and in comparison to other wave indicators they have the great advantage that their deflection is due exclusively to the *current effect*, even though not necessarily proportional to it.

This property of the thermal detectors, however, is not without its danger. For it is conceivable that results obtained with the thermal indicators are applied to methods using other wave detectors without consideration of the question whether the latter also respond to the *current effect*.

2. MAGNETIC DETECTORS²⁵¹

152. The Fundamental Physical Principles.—Assume a magnetic field M induced by means of a permanent or electromagnet in some steel or hard drawn iron wires. If, then, these wires are subjected to the field of an electromagnetic oscillation, *e.g.*, that produced by the discharge of a condenser circuit, the result will be a change in the magnetic flux in the wires. We may state therefore: The *result* of the action of the oscillations—no matter through what processes it is obtained²⁵¹—is a very rapid change in the magnetic flux in the wires.

If the same thing is repeated with the same wires, the effect is only very slight. If it is desired that a second discharge again have a material effect upon the magnetic flux in the wires, it is necessary to alter the magnetic field M between the first and second discharges, as, *e.g.*, by increasing or decreasing the current in the electromagnet, or, if a permanent magnet is used, by altering its distance from the wires.

Hence, if iron or steel is to be used as an indicator of electromagnetic waves and is to react upon any sequence of these, it is absolutely essential that the external field is continuously varied,²⁵² or that new iron parts are constantly subjected to the action of the electromagnetic oscillations.

153. Marconi's Magnetic Detector.—MARCONI, probably following up the work of RUTHERFORD, used two different forms.

a. The first is shown diagrammatically in its essentials in Fig. 327. A bundle of hard-drawn iron wires is enclosed within the winding, S_1 , through which the oscillations of the receiver pass. The variable magnetic field, M , is obtained by rotation of the horseshoe magnet, H , fastened to the axle, A . The rapid change in the magnetic flux in the iron wires caused by the oscillations, induces an e.m.f. in the winding, S_2 .

This produces a clicking sound in the telephone, T , connected in circuit with S_2 , every time an electromagnetic wave strikes the receiver.

b. In practice MARCONI seems to have used only his second method, which is shown diagrammatically in Fig. 328. The iron wires are formed into an endless string or rope, D , running over two grooved pulleys and kept in motion by a clockwork. The magnetic field, M , in the iron wires, is induced by two horseshoe magnets, H , under whose poles the wires are passed.

When the wires pass through the inside of the winding, S_1 , which is connected into the receiving circuit, they are subjected to the action of

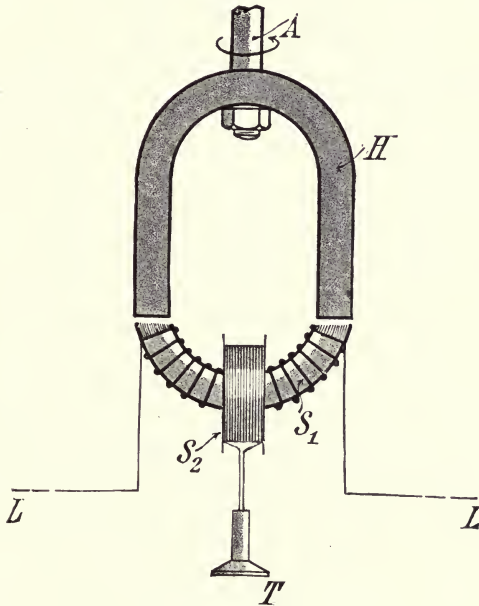

FIG. 327.

the oscillations. The latter are here also indicated by means of a telephone connected to the coil S_2 .

MARCONI succeeded in operating a relay with this detector [Art. 167c] and thereby to automatically record the received messages,²⁵³ but at present he seems to prefer the use of a suspension galvanometer [Art. 167b] for recording telegrams.

154. Other Forms of Magnetic Detectors.—In another class of magnetic wave indicators, the iron body subjected to the action of the received oscillations, is located in a rotating magnetic field, or is itself rotated in a fixed constant field. To this class belong the arrangements²⁵⁴ of R. ARNÖ, J. A. EWING and L. H. WALTER, A. S. ROSSI, R. A. FESSENDEN, W. PEUCKERT and another of L. H. WALTER.

None of these arrangements seem to have entered into radio-practice, for which they are hardly so much intended as for measuring purposes. For measurements, certain of these devices have the advantage that their action is not determined by a single oscillation (as is the case with MARCONI'S magnetic wave indicators) but the effect of a sequence of wave trains is summed up to a certain extent, as with the thermal detectors.

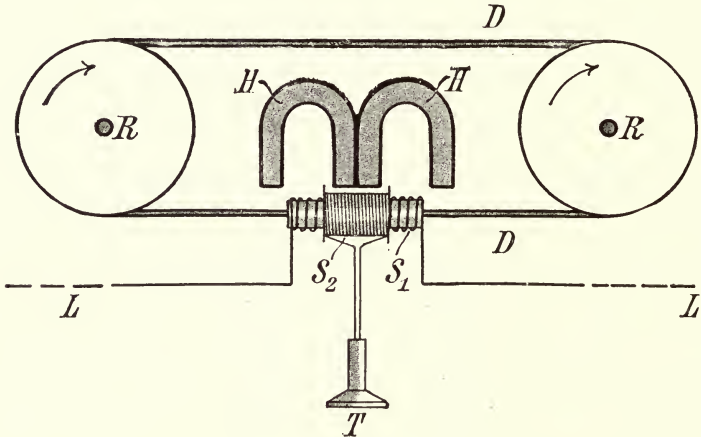

FIG. 328.

3. IMPERFECT CONTACTS

155. Metallic Granular Coherer.²⁵⁵—In its original form the “coherer” consists of a tube of non-conducting material (*e.g.*, a glass tube) with two metallic electrodes, E_1 and E_2 (Fig. 329), between which are a large number of very small pieces of some suitable metal (granules,

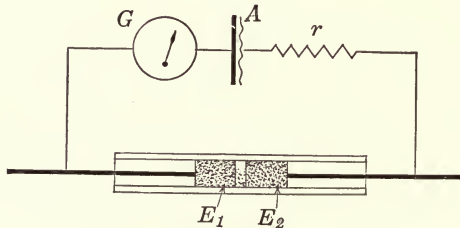

FIG. 329.

shavings). This in its normal condition offers an almost infinite resistance. If, however, sufficiently strong oscillations are passed through this coherer, its resistance is greatly decreased, falling to several thousand or, in some coherers, even to a few hundred ohms or less. This low resistance is retained by the coherer after the oscillations have ceased. In order to bring it back to its non-conducting state, it is necessary to shake it, say, by tapping against the containing tube.

Since the time when BRANLEY showed that this simple device constituted a wave indicator of much higher sensitiveness than the other forms then known, the coherer was improved and developed along the following lines.

a. The *shape* of the coherer was not changed much. MARCONI cut the electrode surfaces at an angle to the axis (Fig. 330) so that the space

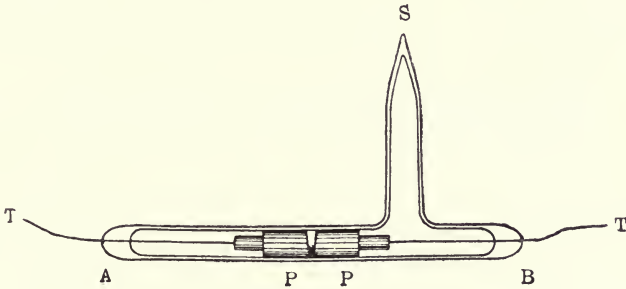

FIG. 330.

between them is wedge-shaped. In this way, upon tapping against the side of the tube where the electrodes are closest together, there is no danger of jamming the metal filings between the electrodes.

b. As to the *material*, very little of a general nature can be stated. MARCONI used silver electrodes in his early work, as it was easy to form an amalgam with the silver, and his filling was a mixture of 96 per cent. nickel and 4 per cent. silver. Similar coherers were long used by the TELEFUNKEN Co. (Fig. 331). Later SCHLÖMILCH, of the TELEFUNKEN Co., devised a very sensitive coherer of gold and aluminium; one electrode being of aluminium, the other of gold, while the filling is gold powder.

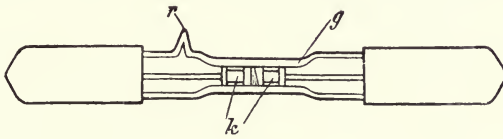

FIG. 331.

A. KOEPEL obtained a very reliable coherer by using highly polished and very hard steel plate electrodes and granules of glass-hard steel.

In regard to the filling, the chemical constituency is by no means the only determining factor, and the shape of the granules is of at least equal importance. In general, high sensitiveness is secured by giving the granules sharp points or edges. The danger of jamming with such granules is minimized by eliminating all those having a long narrow shape.

c. Coherers are frequently exhausted (vacuum), this practice having been originated by MARCONI. Complete dryness inside the coherer is assured in this way—a requirement for reliable operation.

d. Some coherers are arranged with *adjustable sensitiveness*. Where the space containing the metal filings or granules is decidedly wedge-shaped, as in some of the coherers formerly used by the TELEFUNKEN Co., this adjustment is attained by simply turning the coherer, the sensitiveness being greater when the narrow portion of the wedge-shaped space points downward. In other coherers the distance between the electrodes is adjustable, as in those of A. KOEPEL, also in those of H. BOAS (Fig. 332)* which latter are in a vacuum. Regulation of the electrodes through

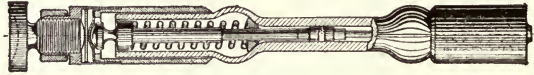

FIG. 332.

the air-tight ends is made possible by a flexible metal diaphragm† which closes the tube at one end and against which one of the electrodes is pressed from within by means of a spring. If, then, the micrometer screw is turned from the outside, this brings pressure against the diaphragm, thereby moving one of the electrodes within certain limits.

156. Mercury Coherers.—a. In some experiments of the Italian Navy, the coherer‡ shown diagrammatically in Fig. 333, was tested. Two electrodes, either both of iron or one of iron and one of carbon, are placed in a glass tube, and between the electrodes is a drop of mercury.

This coherer, which was also used by MARCONI for a time in some of his long distance work, seems to be more sensitive than those having solid metal



FIG. 333.

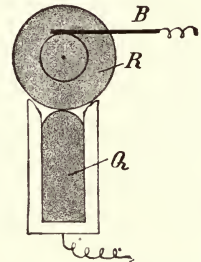

FIG. 334.

granules. Moreover, it differs from these in that after the oscillations have ceased, it *automatically* returns to its initial high resistance.§ This form of coherer is no longer used in practice, however.

b. Another form of mercury coherer has been devised, apparently independently by A. KOEPEL on the one hand and by O. LODGE and A. MUIRHEAD on the other hand.²⁵⁶ The construction adopted by the latter is shown diagrammatically in Fig. 334. A small steel wheel, *R*, to which current is brought through the brush, *B*, is rotated by clockwork

* From a pamphlet of H. BOAS.

† The metal diaphragm is soldered to a metal tube which, in turn, is soldered to the platinum coating on the glass.

‡ Apparently the idea originated with an Italian Signal Officer named CASTELLI.

§ It is "self-restoring."

or by a small motor. The wheel dips slightly into mercury, *Q*, which is covered by a thin layer of mineral oil. Normally the wheel and mercury do not make a conducting contact; a contact is formed, however, as soon as oscillations pass through this coherer and disappears again as soon as the oscillations cease.

These coherers of LODGE and MUIRHEAD seem to have given good service in practice.

According to the investigations of W. H. ECCLES, the action of this detector, as well as of that described in *a*, seems to depend upon the negative temperature coefficient of the iron oxide coating which forms on the iron or steel electrode. If the oxide at the point of contact becomes heated by the oscillations, its resistance is greatly decreased and the current from the battery supplying the detector circuit (see Fig. 329) rises considerably above its initial value.

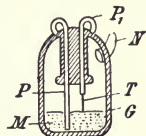

FIG. 335.

c. L. H. WALTER²⁵⁷ devised a very useful and also self-restoring mercury coherer, the sensitive contact being made between a *tantalum point* (*T*, Fig. 335) and mercury (*M*). This detector is said to be not quite so sensitive as, *e.g.*, the electrolytic, with very weak oscillations, but with strong oscillations it gives much louder sounds in the telephone.

157. Carbon or Graphite Coherers (Microphone Contact).—Another class of coherers makes use of carbon or graphite. Two arc-lamp carbons, one resting loosely upon the other, or either an arc-lamp carbon or a graphite rod together with a wire constitute the simplest, though impractical forms of this type of coherer. They suffice for the detection of electromagnetic oscillations as well as any microphone, which latter in fact was used by HUGHES for this purpose as far back as 1879. These coherers, like those made of metal granules, change their resistance when oscillations are passed through them, but differ from them, resembling the mercury coherers in this respect, in that they are self-restoring.

This coherer was used in practice for quite some time in the form, devised by A. KOEPEL, in which the imperfect contact consisted of a highly polished, very hard steel plate and a hard graphite rod. This combination is very sensitive but is not sufficiently reliable for regular practice.

4. ELECTROLYTIC AND OTHER DETECTORS

158. Anti-coherers.—This name is frequently applied to those detectors in which the effect of the electromagnetic oscillations, instead of being a *reduction* is an *increase* in the resistance; these anti-coherers moreover are self-restoring.

a. *De Forest's "Responder."*—In a tube of non-conducting material there are, as in the ordinary coherer, two metallic electrodes, which sometimes are hollowed out as shown in Fig. 336. The space between them is

filled with a paste which in one case, *e.g.*, consists of water and glycerine, metal filings and pulverized lead.

DE FOREST gives the following explanation of its action. If this detector is placed in a battery circuit, a small current flows through it. The resulting electrolysis, causes the formation of very fine metallic bridges between the metal filings. The effect of the oscillations is to destroy these bridges. When they cease, however, the current immediately causes the bridges to form again so that the wave indicator resumes its normal resistance.

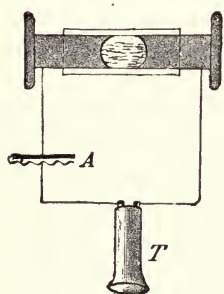

FIG. 336.

b. The detector of J. E. IVES²⁵⁸ contains two crossed silver wires, which almost make contact in a solution of potassium bromide or iodide or of both. Here the formation of the bridges between

the two wires has been observed under the microscope.

159. The Electrolytic Detectors of Ferrié, Fessenden, Nernst and Schlömilch.—It seems that the electrolytic detector, to be described in what follows, was announced independently by FERRIÉ, R. FESSENDEN, NERNST and W. SCHLÖMILCH after M. I. PUPIN, at a much earlier date (U. S. Patent, 713045, 1898) had used a similar cell for rectifying alternating currents. The following is a description of the form in which the electrolytic detector was used by the TELEFUNKEN Co., under the name of "SCHLÖMILCH cell" (Fig. 337):

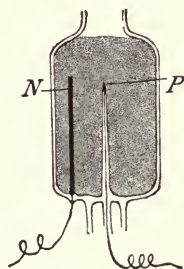

FIG. 337.



FIG. 338.

In a container filled with dilute sulphuric acid there are two platinum wire electrodes, one of which is very thin and covered by glass tubing, except at its end where the bare wire projects for a very short distance. This thin wire is connected to the positive pole, the heavier wire to the negative pole of a battery whose e.m.f. is only slightly greater than the e.m.f. which is produced by the polarization of the cell, platinum—dilute sulphuric acid—platinum. Consequently a very small current flows through the cell, so that a galvanometer connected in circuit would show a

slight deflection. As soon as oscillations act upon the detector, a considerable increase in the current results, so that the galvanometer in the cell circuit has a much greater deflection and a clicking sound is heard in a telephone connected in the circuit. The moment the oscillations cease, the current falls to its normal value. Fig. 338* is an exterior view of the detector.

In FESSENDEN'S²⁵⁹ "liquid barretter" (Fig. 339) the point of a fine Wollaston wire (platinum wire coated with silver) just dips into the surface of the electrolyte (potassium nitrate solution);† here also the Wollaston wire is joined to the positive pole. A very fine adjustment makes it possible to secure the most efficient depth of submersion and also enables prompt readjustment in case the point of the wire is harmed at any time by too heavy a discharge.

a. The characteristic properties of the electrolytic detector are:

1. The sensitiveness increases as the surface area of the positive electrode decreases. Hence, an extremely small electrode is used for radio-purposes. In the

SCHLÖMILCH detector it is a platinum wire of about 0.03 mm. diameter, in glass, from which it projects only very slightly, while in FESSENDEN'S liquid barretter it is a Wollaston wire of still much smaller diameter.

2. The normal resistance of the cell, when not excited by oscillations is only several thousand ohms, hence is of about the same order as that of the coherer when excited.

3. Other things being equal‡ the galvanometer deflection or the intensity of the sound in the telephone increases as the amplitude of the oscillations is increased.²⁶¹

The investigations of G. W. PIERCE¹ (which, however, were made with low frequency alternating current) indicate that the electrolytic detector

* From a pamphlet of the TELEFUNKEN Co. In this form the positive electrode is renewable. A later construction of the TELEFUNKEN Co's. electrolytic detector has three fine wire electrodes, which can be used alternately.²⁶⁰

† According to J. E. IVES²⁵⁹ a solution of caustic potash (1 vol. saturated solution to 2 vols. water) increases the resistance of the detector, but also increases the range of its variation due to the oscillations. IVES used a Wollaston wire of 0.001 mm. diameter (of the platinum), submerged to a depth of about 0.1 mm.

‡ That is, with constant decrement, as this determines the galvanometer deflection as well as the amplitude of the oscillations.

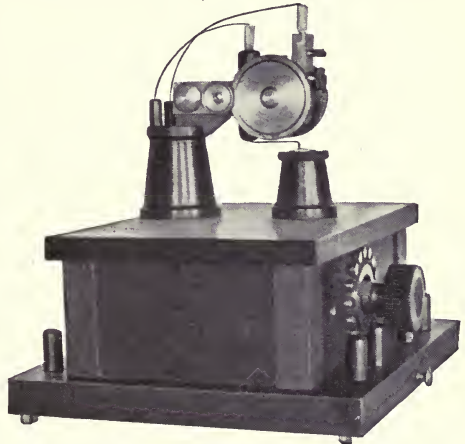

FIG. 339.

acts as a rectifier due to the polarization [see Art. 162*a*], the resultant current being unidirectional.

b. FESSENDEN²⁶² found that with his liquid barretter the signals in the telephone became louder and sharper on applying a pressure of three to four atmospheres to the barretter.

c. The customary method is to connect the electrolytic detector in series with a battery and a telephone. It has often been proposed to eliminate the battery, by using for the non-sensitive electrode of the detector, a metal which, together with the sensitive electrode, will form a galvanic cell of suitable e.m.f.

160. Crystal Detectors.—There are a number of crystalline substances which, when substituted for the coherer in the arrangement of Fig. 329, produce a galvanometer deflection or sound in the telephone, whenever oscillations are passed through the circuit. All these substances can, therefore, be used as wave indicators.

a. The use of these substances as wave indicators probably originated with the experiments of F. BRAUN (1901)²⁶³ in connection with *psilomelan* (a complex mineral of irregular composition and containing manganese), also with galena (PbS), iron pyrites (FeS₂) and pyrolusite (MnO₂). At the suggestion of BRAUN, the TELEFUNKEN Co. developed the *psilomelan* detector; its sensitiveness was brought to a degree about equal to that of the SCHLÖMILCH electrolytic detector.

The following substances have since then been proposed and widely used in practice:²⁶³ carborundum (SiC) (DUNWOODY), titanium dioxide (TiO₂), molybdenite (MoS₂) (G. W. PIERCE), copper pyrites (CuFeS₂), also (Cu₃FeS₃), chalcocite (Cu₂S), manganese dioxide (MnO₂), and iron pyrites (FeS₂).

The usual method is to place a small piece of one of these minerals between two metal electrodes (of almost any suitable material) under light pressure, and in series with a battery and telephone in the circuit receiving the oscillations. The use of a plate of the detector material in conjunction with a metallic powder (thus, molybdenite—powdered silver) has also been proposed.

In this same class also belongs the detector of S. G. BROWN, in which lead peroxide is placed between a lead and a platinum electrode, the lead being connected to the negative, the platinum to the positive pole of the battery.

b. In a second class of detectors either a combination of two minerals or of one mineral with some specific metal is used. To this class belongs, *e.g.*, the “*perikon*” detector of G. J. PICKARD,²⁶³ which is a combination of zinc oxide (ZnO) and copper pyrites (CuFeS₂).

c. As to the nature of the action of these detectors,²⁶⁴ it suggests itself that this may be thermoelectric. In fact C. TISSOT has shown that this is very probably the case with a number of detectors—the combinations

metal-copper pyrites, metal-chalcocite, metal-manganese dioxide, metal-tellurium. He proved that:

1. These detectors are sensitive only if the contact is limited to a point.
2. They operate without a battery in series, and when a battery is used the sensitiveness does not depend upon the value or direction of its e.m.f.
3. The direction of the current (direct) obtained under the influence of the received oscillations is always the same as the direction of the thermo-e.m.f.

With another group, however—carborundum, anatase (titanium dioxide), molybdenite and the perikon detector—Tissot's tests established that:

1. The form of the contact is of little or no importance, even relatively large polished plates placed between two metallic electrodes make sensitive detectors.
2. The use of a battery in series with the detector, with proper value and direction of the battery e.m.f., increases the sensitiveness.
3. The sensitiveness of these detectors bears no relation whatever to the value of their thermo-e.m.f.

He, therefore, concludes that in this last mentioned group thermo-electric forces play no important part in their action as detectors.

G. W. PIERCE,¹ as the result of extensive investigations, including oscillograph records made with the BRAUN tube, concluded that with carborundum, anatase, brookite (another form of TiO_2) and silicon, thermoelectric forces were not involved, but that these detectors were better conductors in one direction than in the other, in short, act as *rectifiers* [Art. 162].

161. Incandescent Lamp Detectors, Gas Detectors.—*a.* J. A. FLEMING²⁶⁵ observed the following phenomenon: An electrode (*A*, Fig. 340), say of cylindrical form, is fused into an incandescent lamp bulb, whose filament is made incandescent by means of a battery, *B*.* A circuit containing a galvanometer, *G*, (or telephone) and a coil, *S*₂, is joined to the electrode, *A*, at one end and to the lamp filament, at the other, *K*. The aerial coil *S*₁ is coupled with *S*₂; hence if oscillations pass through *S*₁, the oscillations induced in the circuit $\overline{AGS_2K}$ will cause the galvanometer to deflect (or produce a sound in the telephone). The galvanometer needle will return to its zero position as soon as the oscillations cease, *i.e.*, the arrangement is a self-restoring wave indicator.

Several years ago C. TISSOT²⁶⁵ used this wave indicator for measurements over considerably long ranges but he complains of the irregularity

* A choke coil [Art. 165*b*] should be inserted in the leads from the battery to the lamp.

of the deflections.* But in the more recent form of FLEMING'S "oscillation-valve," the anode being a cylinder of carbon and the cathode a tungsten wire, this detector seems to have met all reasonable requirements as to sensitiveness and reliability. This is borne out by the fact that MARCONI has been using it, in conjunction with an EINTHOVEN string galvanometer, in his transatlantic stations.

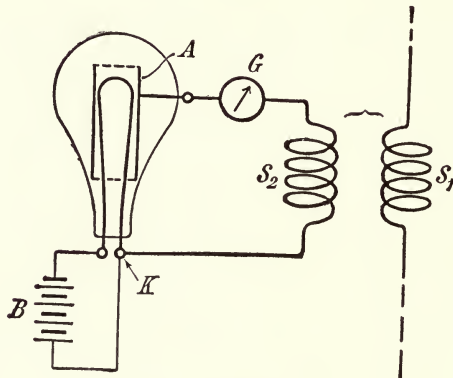

FIG. 340.

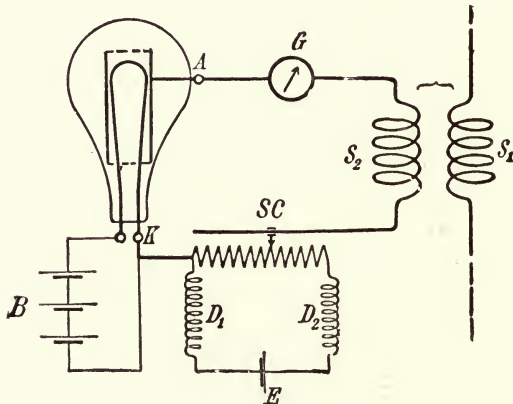

FIG. 341.

The incandescent lamp may be replaced by the tube devised by A. WEHNELT²⁶⁶ which operates in the same manner. The incandescent cathode of this tube is a wire coated with a metallic oxide, and the anode is a hollow aluminium cylinder, concentric with the cathode.

b. H. BRANDES²⁶⁷ has found that it is very advantageous to insert an auxiliary battery or cell, *E*, about as shown in Fig. 341,† when using

* TISSOT²⁶⁵ describes a wave indicator using rarified air (as in the ZEHNDER tube), which he found to be less sensitive but better adapted for measuring purposes.

† *D*₁ and *D*₂ are inductive coils.

these wave indicators. The sliding contact, *SC*, is adjusted until the detector is operating at the best point of its characteristic [see Art. 162*a*], thereby greatly increasing the sensitiveness as compared to operation without the auxiliary cell. This method has lately also been adopted by FLEMING.

c. This arrangement had in fact been proposed quite some time ago by DE FOREST in his so-called “*audion*” detector. The audion, as first constructed, was in the main identical with FLEMING’s construction, excepting that DE FOREST made use of an auxiliary cell (*E*, Fig. 341) from the very first.

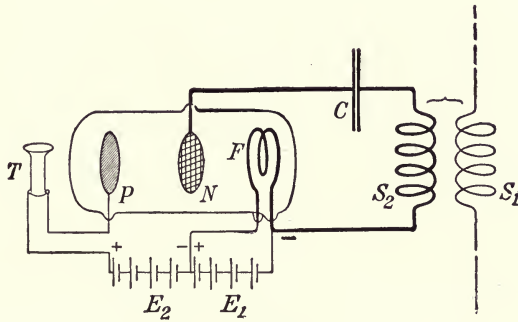

FIG. 342.

Another construction of DE FOREST’s “*audion*,”²⁶⁸ which seems to be of particular excellence is that shown diagrammatically in Fig. 342. Here *F* is the metallic filament made incandescent by the current from the battery, *E*₁, *N* is a wire grid or network and *P* is a disc-shaped electrode. All three electrodes are placed in an exhausted glass bulb.

5. GENERAL CONSIDERATION OF DETECTORS

162. The Nature of the Action in Various Detectors.—*a.* H. BRANDES²⁶⁷ has shown that the action of very many wave indicators may be generalized under a single, common point of view.

All these wave indicators have in common the fact that they do *not* follow OHM’s law, so that their characteristic [Art. 113] instead of being a straight line, is an *irregular curve*.

This variation includes two cases, viz.:

1. The curve is not symmetrical in the first and third quadrants (Fig. 343), *i.e.*, the current is not the same for any two potentials of equal amplitude but opposite sign. Hence, if the potential is that of an alternating current or oscillation, the resulting current is not the same in both directions. Consequently the currents in two directions do not neutralize each other in their action upon a galvanometer which shows a deflection without the insertion of an auxiliary battery; likewise a tele-

phone in the circuit is caused to produce a "click."* The detector therefore is said to be a "rectifier."†

2. The characteristic curve is symmetrical in the first and third quadrants (Fig. 344).

In this case the oscillations will cause equal currents to flow in both directions, so that the detector, *per se*, does not act as a rectifier and a galvanometer in the circuit does not deflect.

If now, however, the constant potential of an auxiliary cell is impressed across the poles of the detector, an increase in the total e.m.f. due to the oscillations causes a certain increase in the current flowing through the

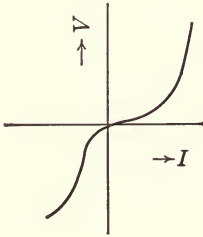

FIG. 343.

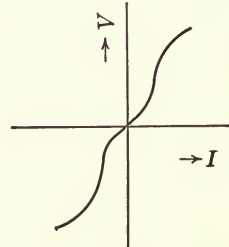

FIG. 344.

detector; an equal decrease in the e.m.f. due to the oscillations, however, does not produce an equal decrease in the current, because of the curvature of the characteristic. Hence the effect of the oscillations is to change the galvanometer deflection or produce a click in the telephone; the detector *with a battery in series* acts as a rectifier.

The rectifying action has been shown by BRANDES to be greater (1) the steeper the characteristic is toward the axis of abscissæ at the point corresponding to the e.m.f. of the auxiliary cell, and (2) the sharper its curvature is at this point. Hence, in using this class of detectors, the auxiliary e.m.f. must be so chosen or adjusted as to permit of operation at the most favorable point of the characteristic.‡

b. Many *investigations* of the characteristics and action of the various detectors have been made.²⁶⁹ It has been shown that with incandescent lamp, electrolytic and the various crystal and thermal detectors (carborundum, perikon, graphite-galena, copper-molybdenite, anatase, brookite) the characteristic assumes entirely different shapes upon reversal of the current. Thus, Fig. 345 shows the characteristic of the highly sen-

* This explains FERRIE'S observation of the fact that the electrolytic detector acts as a wave indicator without the presence of a battery in the circuit.

† In some cases current passes in one direction only, the detector acting more or less as a valve.

‡ The heating devices of the detectors described in Art. 150c have a similar purpose; they are adjusted to give the temperature at which the characteristic will have its most favorable curvature.

sitive perikon detector [Art. 160*b*] as obtained by the measurements of W. H. ECCLES.²⁶⁹

ECCLES also investigated the relation between the sensitiveness of various detectors and the value of the impressed auxiliary e.m.f. and in almost all cases found that maximum sensitiveness corresponded to a certain value of the auxiliary e.m.f. in agreement with the conclusions of BRANDES.

He also investigated the relation between the D.C. energy delivered by the detector to the telephone and the energy supplied to the detector by the oscillations and, in all cases coming under his observation,* he found that the curve representing the relation between D.C. energy delivered and the high frequency energy sup-

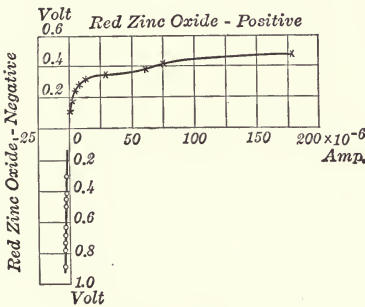

FIG. 345.

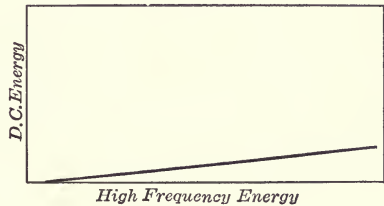

FIG. 346.

plied, is a straight line which does not quite pass through the common zero point (Fig. 346). Hence there is an *initial value* above which the oscillating energy must lie to produce useful D.C. energy. The ratio of the D.C. energy to the high frequency energy supplied, *i.e.*, the *efficiency* of the detector, was found, under the conditions of the tests made by ECCLES, to be 13 per cent. for the electrolytic detector (sensitive electrode 0.006 mm. thick, sulphuric acid electrolyte), 9.3 per cent. for the carborundum detector, 13 per cent. for the perikon detector and about 3 per cent. for graphite-galena, the figures being the maximum obtained in each case.

These tests are of particular value, because the conditions (frequency, energy) encountered in the actual practice of radio-telegraphy were retained as closely as possible, which can by no means be stated of all the investigations which have been made in this field of work.

163. What do the Different Types of Detectors React Upon?²⁷⁰—a.

Assume that only a *single* oscillation (say a single discharge from a condenser circuit) acts upon a wave indicator. Then:

1. The reaction of the *thermal* detectors, and to some extent also of mercury coherers, depends upon the heat developed within them, *i.e.*, upon the current effect $\frac{1}{4Nd} \cdot I_0^2$.

* Iron-mercury, electrolytic detector, carborundum, perikon detector, graphite-galena.

2. For *magnetic* detectors, the amplitude (or the maximum amplitude [Arts. 56c and 61c]) of the current, I_0 (or I_{max}) is probably the determining factor.

3. For *rectifying* detectors, the quantity of electricity passing in one direction in excess over that quantity passing through the detector in the other should be the determining factor. This excess quantity depends not only upon the amplitude of the potential occurring between the poles of the detector, but also upon the damping. Where the rectifying action is complete so that the resultant flow of current is unidirectional, this quantity is approximately* $= \frac{1}{\pi N d} \cdot I_0$, hence like the current effect, it varies as $\frac{1}{N d}$, but it varies as I_0 , not as I_0^2 .†

With the metallic coherers, a certain minimum potential difference between the electrodes must exist to produce a reaction. However, in order to cause a *large* change in the resistance, as is required in practice, a certain current effect must be reached. In this respect, therefore, the coherer is not unlike the thermal detectors, for its action also depends upon the decrement of the oscillations as well as upon the amplitude.

b. Assume that a very *rapid sequence* of oscillations (*e.g.*, undamped oscillations or damped oscillations of very high discharge frequency acts upon the detector. Then there are two possible cases, *viz.*,

1. The effect upon the wave indicator is determined entirely or almost entirely by the first oscillation. The oscillations which follow do not materially aid the action. This is the case, *e.g.*, with the coherer and with MARCONI'S magnetic detector.

2. The effect upon the wave indicator is the sum of the effects of the successive oscillations in the series. This undoubtedly is the case with the thermal detectors, the magnetic detectors of the WALTER type [Art. 154], to a certain extent also with the electrolytic detectors of the SCHLÖMMLICH type and in general, with all those to which Art. 162 applies.

In considering this question, however, it is important to distinguish sharply between the effect upon the detector and that upon the receiving apparatus. If, *e.g.*, the discharge frequency is increased, while the amplitude and damping remain constant, there is no doubt that the effect upon a thermal detector, in other words, that the direct current delivered by it will also increase, other things being equal. Nevertheless the intensity in the receiving telephone [see Art. 165] may decrease with the increased discharge frequency. The amplitude of the oscillations of

* The exact value is $\frac{I_0}{\pi N} \cdot \frac{e^{-\frac{d}{4}}}{1 - e^{-d}}$

† It seems that the action of certain detectors, which are generally considered as perfect rectifiers, depends upon the current effect. If that is the case, then these detectors can not be pure rectifiers.

the telephone diaphragm, depends not only upon the amplitude of the D.C. impulses but also upon their variation with time and upon the length of the intervals between them; if these intervals become too short the amplitude of the telephone diaphragm's motion may decrease.

c. If the individual oscillations follow one after the other with relative *slowness* (e.g., damped oscillations produced by means of a resonance transformer) then not only the wave indicator, but also the method of reception will determine whether or not the effects of the individual oscillations are summed up. Thus when receiving with a telephone only the effect of a single oscillation comes into question, whereas with a siphon recorder [Art. 167a] or similar devices the result is a summation of the individual effects.

164. Testing the Sensitiveness of Detectors.²⁷¹—A general statement as to the *relative sensitiveness of two detectors* is often impossible when the detectors are of a different type.

a. The ratio moreover may vary as the character of the oscillations used for the test varies; thus it may be different for undamped than for damped oscillations, and, again, with damped oscillations it will depend upon the amplitude, the decrement and the discharge frequency. At twenty discharges per second, a good coherer will receive at practically the same range as a thermal detector, but at 1000 discharges per second, with the same transmitted energy and a corresponding decrease in amplitude, the range of the thermal detector will be over five times that of the coherer (COUNT ARCO¹⁶⁰).

Hence where it is desired to determine which of two detectors is the most sensitive for service from a given station, it is advisable to let a closed oscillating circuit whose oscillations have just about the same time variation and discharge frequency as the waves of the station in question, act upon the detectors. The alternative method of using any of the so-called station testers or, perhaps, as is frequently done, of using an interrupted direct current to act upon the detectors, can only give very questionable results.

b. Different arrangement of the receiving circuits may also greatly affect the relative sensitiveness of two detectors. Thus, the results may differ if the detectors are connected to a weakly damped receiving condenser circuit as compared to inserting them in a closed (aperiodic) circuit [see Art. 175 *et seq.*].

c. Finally the receiving apparatus itself may greatly influence the relative sensitiveness and hence the attainable range. Thus telephone reception may give quite different results than a recording receiver involving the use of a relay.

All these factors must be carefully considered in comparing detectors as to their sensitiveness.

6. RECEIVING APPARATUS

165. Telephone Reception.—The receiving apparatus assumes its simplest forms with those wave indicators which are self-restoring upon cessation of the oscillations or which at least are able to immediately indicate a new oscillation (including all wave indicators with the exception of the metallic coherer). With these a *telephone* can be used as the *receiver*.

a. The simplest method of connection for wave indicators without an auxiliary cell, is shown diagrammatically in Fig. 347* and for wave indicators with an auxiliary cell, in Fig. 348.† In these *J* is the wave indicator, *T* the telephone, *E* the auxiliary cell and *L* the receiving circuit containing *J*.

A telephone thus connected when held to the ear produces a clicking sound at each discharge of the transmitter, if the discharge frequency is low. If this frequency is high, either a pure tone is heard in the telephone in which case the discharge frequency is regular and within the range of audibility, or otherwise a buzzing discordant sound is heard.

The letter “a” (.— in the MORSE code) is heard in the telephone as a short (dot) click, buzz or tone followed by a longer sound (dash) of the same character. Telegrams can therefore be received by means of the ear, just as with the sounders or buzzers used in wire telegraphy.

b. For *wave indicators with an auxiliary cell* the arrangement requires a slight modification.

Firstly, it is advantageous to impress the particular e.m.f. at which the indicator is most sensitive [Art. 162*a*]. To adjust for this, a high resistance, *AB* (Fig. 349), is connected across the terminals of the cell *E*, which should have a relatively high e.m.f., and is

provided with a sliding contact, *K*.‡ Then any desired voltage, up to that of the cell, *E*, can be obtained between *K* and *B* and hence across the terminals of the wave indicator, *J*.

Furthermore, the connections of Fig. 348 would have the disadvantage of causing the oscillation currents in the circuit *L* to partly branch off

* The receiving circuit, *L*, must of course form a complete closed circuit. If the telephone is connected in parallel to the wave indicator, then the circuit *L* must have a condenser (*block condenser* [Art. 41*d*]) in it, in order to prevent the direct current of the wave indicator from flowing into it.

† But see *b*.

‡ This is simply a “potentiometer” connection.

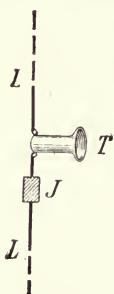

FIG. 347.

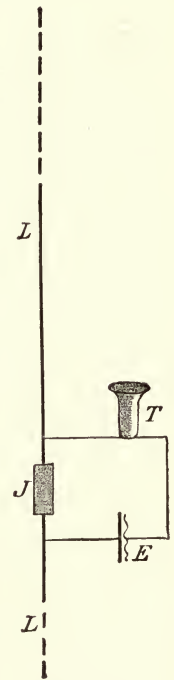

FIG. 348.

into the telephone circuit *TE* (Fig. 348) so that only a part would pass through the wave indicator. To prevent this two *choke coils*, D_1 and D_2 in Fig. 349, are inserted at the junction points to block the path of the oscillations through the telephone circuit [Art. 41b].

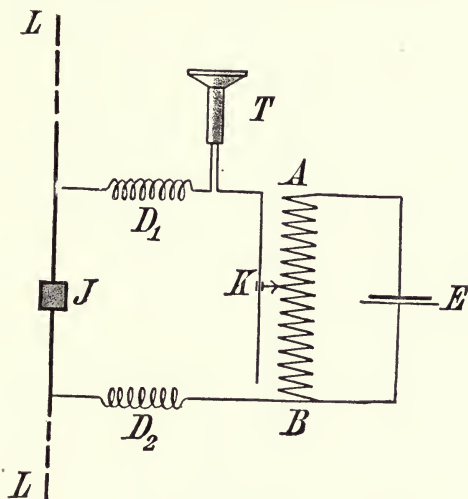

FIG. 349.

166. Amplification of the Sound in Telephone Reception.—Two devices which have been successfully used for intensifying the sound produced in the receiving telephone, are the telephone relay of S. G. BROWN and the so-called “sound intensifier” of the TELEFUNKEN CO.

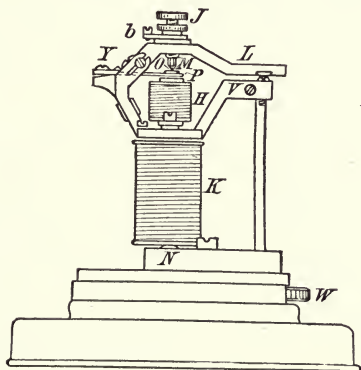

FIG. 350.

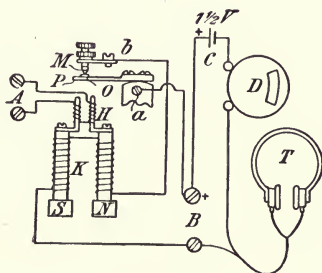

FIG. 351.

In both apparatus, the detector current first acts upon a kind of microphone and the microphone current then flows through the telephone.

a. The *Brown telephone relay*²⁷² is illustrated in Figs. 350 and 351, the latter showing the connections. *N* and *S* are the poles of a

horseshoe magnet, on which two soft iron cores whose windings are marked *K* and *H* rest. *P* is a steel tongue carrying a small osmium-iridium plate *O*, which lightly touches a contact point *M* also consisting of an osmium-iridium alloy. *C* is a dry cell whose circuit contains the contact *OM*, the winding *K* and the telephone *T*. The current, whose effect upon the telephone is to be amplified, is sent through the winding *H*. This causes the steel tongue, *P*, which takes the place of the telephone diaphragm to vibrate, thereby alternately strengthening and weakening the current in the circuit *COMKT* in unison with the oscillations, with the result that a materially stronger effect is produced upon the telephone, *T*, than if the current in *H* were sent direct through *T*.

Tests made by the British Admiralty and Post Office Departments indicated that this telephone relay doubled the range. Messages whose existence could not be discovered with the ordinary telephone apparatus

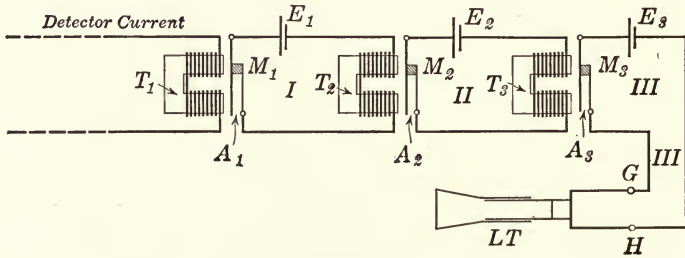

FIG. 352.

were easily received with the BROWN relay. During tests made between the Clifden and Poole stations in Ireland, by using two relays connected in series it was possible to clearly hear messages 2 m. away from the receiver, while in the ordinary receiver without relay the same message could just be discerned as a slight noise.

b. In the *Telefunken Tone Intensifier*²⁷³ which is adapted only for use with a tone transmitter, the detector current is conducted to a small electromagnet (*T*₁, Fig. 352) having a large number of turns. In the field of the magnet there is a small armature *A*₁, whose natural frequency of vibration corresponds to the frequency of the detector current and hence to the tone of the transmitter. This resonant armature presses against a microphone contact, *M*₁, which is in the circuit of a local battery, *E*₁. This circuit also contains an electromagnet, *T*₂, constructed identically as *T*₁. The current flowing through *T*₂ pulsates at the same frequency as the detector current flowing through *T*₁, but has a much greater amplitude. Hence the armature, *A*₂, which is identical with *A*₁, vibrates more violently than *A*₁, so that the pulsations in circuit *II*, which contains the microphone contact, *M*₂, local battery, *E*₂, and electromagnet, *T*₃, become still greater than in circuit *I*. Armature *A*₃ and microphone

contact M_3 then produce another increase in the pulsations. This three-fold amplification is sufficient to produce a current of about 10^{-2} amp. in circuit *III*, which contains the receiving telephone, when the detector current is only from 10^{-7} to 10^{-8} amp.

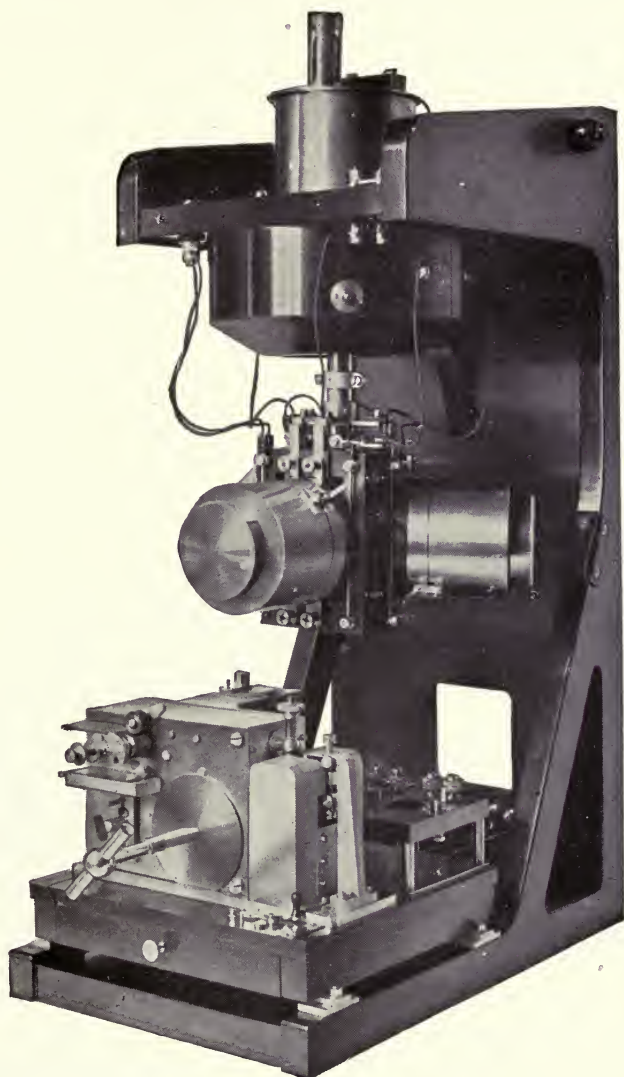

FIG. 353.

In conjunction with the intensifier it is customary to use a special loud-speaking telephone (*LT*, Fig. 352), having an acoustic resonator at the opening of its mouthpiece, the resonator being tuned to the tone of the transmitter, thus causing a further amplification.

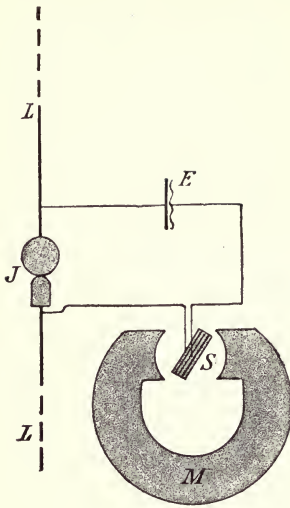

FIG. 354.

a. LODGE and MUIRHEAD'S method* as applied to their mercury

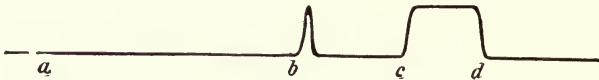

FIG. 355.

coherers is as follows (Fig. 354).† A pen or pencil is attached to the movable coil, *S*, of a galvanometer and touches a paper strip or tape which is moved by clockwork, as in the ordinary MORSE recorder. As the galvanometer coil rotates the pen or pencil is moved perpendicularly to the direction of motion of the paper.

As long as the wave indicator is not subjected to oscillations, the galvanometer coil remains stationary and the record is simply a continuous straight line (*a* to *b* in Fig. 355). A brief excitation of the wave indicator—*i.e.*, a MORSE dot—produces the effect shown at *b* in Fig. 355, while a dash appears as shown at *c-d*.

b. Later the movable coil galvanometer used by LODGE and MUIRHEAD was replaced by the much more sensitive and

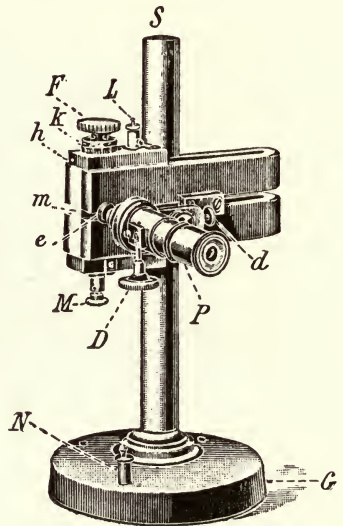

FIG. 356.

* The complete outfit is frequently called "*Siphon recorder.*"

† *M* is the horseshoe magnet of the movable coil galvanometer.

less sluggish EINTHOVEN string galvanometer and a photographic record of the message made.

The EINTHOVEN string galvanometer (FIG. 356)* as is well known, consists of a fine wire (Wollaston wire, fine metal strip or conductive quartz fiber), which is stretched in the gap between the poles of a magnet perpendicularly to the magnetic flux lines (between *F* and *M* in Fig. 356). If current is passed through this wire, the latter will be displaced from its normal position in a direction perpendicular to its axis and to the magnetic flux lines.

The wire moves in front of a narrow illuminated slit (Fig. 357). A photographic reproduction of the slit and wire on a sensitive film passing perpendicularly across the slit, appears, on the negative, as a broad dark band, with a fine light line (the wire) through its center. If, however, the wire is displaced from its normal position, first for a brief instant, and then for a somewhat longer duration, the photographic record will appear as a light line similar to the line of Fig. 355, *i.e.*, the characteristic dot and dash.

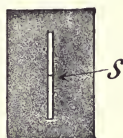

FIG. 357.

A complete photographic recorder²⁷⁵ is illustrated in Fig. 358.† At the left is the galvanometer, whose wire and slit are illuminated by a small incandescent lamp (of which the plug and flexible lead are visible).

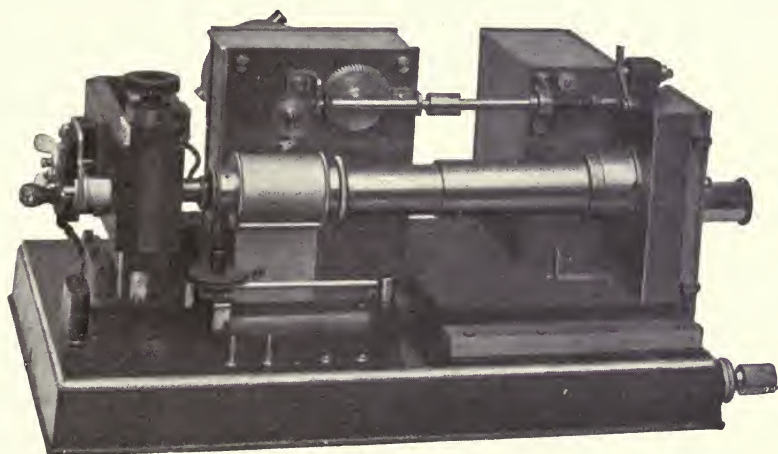

FIG. 358.

The micro-photographic lens is placed in the metal tube, at the right is the camera and in back of this is the case in which the strip of sensitive

* The cut is taken from a catalogue of PROF. EDELMANN & SON (Munich) who make this and also more modern types of galvanometer. The firm of E. HUTH²⁷⁴ makes still another construction of the instrument.

† Construction of the C. LORENZ CO. Other receiving apparatus of the same kind are constructed along very similar lines.

film which is moved by clockwork, is developed and fixed. It has already been mentioned that MARCONI also uses the EINTHOVEN string galvanometer in his transatlantic stations [Art. 161a].

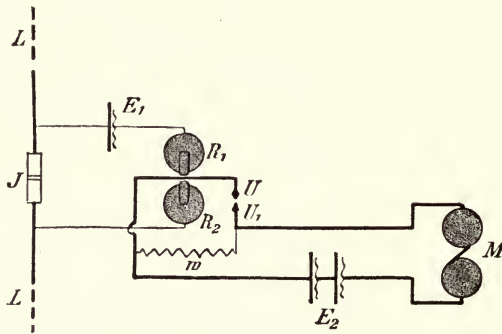

FIG. 359.

c. In place of a galvanometer, a relay (R_1R_2 , Fig. 359) which opens and closes the circuit of a MORSE recorder, M , and local battery, E_2 (Fig. 359),* can be used.

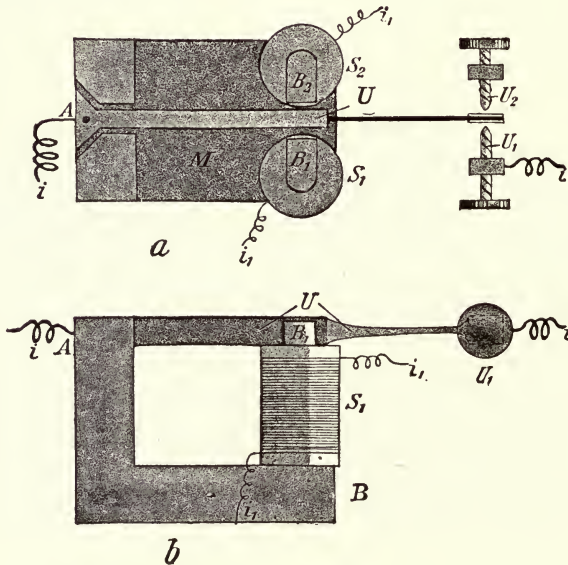

FIG. 360.

The construction of a *polarized relay* which is customarily used for this purpose, is no doubt evident from the diagram of Fig. 360 (*a*, view from above; *b*, view from side). M is a permanent steel magnet, with one

* In regard to the resistance, w , in Fig. 359, see Art. 168*b*. The choke coils, which here also are inserted to protect the relay from the oscillations in the main circuit, L , have been omitted in the diagram.

pole at A , the other at B . On the latter are placed the iron cores, B_1B_2 , of the coils, S_1 and S_2 , which are in circuit with the wave indicator and a battery through the leads i_1 . U is a movable armature which makes contact with U_1 closing and opening the circuit i which, in addition to the MORSE recorder (M , Fig. 359) contains a battery of one or more cells.

A relay of this kind is quite sensitive. Thus the TELEFUNKEN²⁷⁶ relays of this type were stated to respond positively when operated with 1.4 volts and a series resistance of 100,000 ohms. So high a degree of sensitiveness is attainable only if the adjustments for the distance B_1B_2 and the contacts U_1U_2 are particularly fine. Furthermore, the armature U must be balanced with exceptional care to prevent interference from outside disturbances or from the rolling of the ship when used at sea.

The TELEFUNKEN Co. formerly used a *magnetic adjustment*²⁷⁶ on its relays. By turning a piece of soft iron mounted on the casing of the relay, the magnetic field within was varied, thus providing the desired regulation. This, moreover, has the advantage of entirely enclosing the relay in its casing, so that its other adjustments remain fixed once and for all. The external appearance of the relay is shown in Fig. 361.²⁷⁶

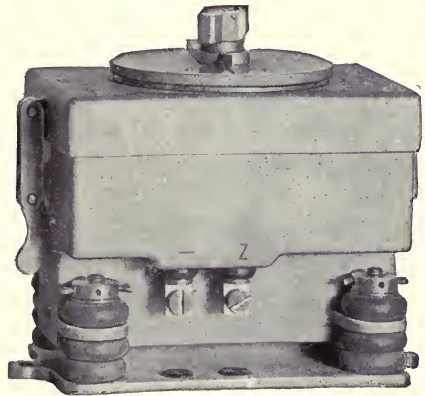

FIG. 361.

The reason for not simply inserting the MORSE apparatus directly in the same circuit as the relay is as follows: On the one hand, the potential existing across the terminals of any of the usual wave indicators in their unexcited condition is limited to a certain maximum value, above which (at most 2 volts, usually much less) it must not be permitted to rise. On the other hand, only very small currents (usually considerably below $\frac{1}{1000}$ amp.) can be allowed to flow through the majority of detectors during excitation without harming them. This combination of very low voltage with very small current is generally sufficient to operate a sensitive relay but not a MORSE recorder.

d. Some detectors in fact can not stand a current sufficient to operate a sensitive polarized relay. Hence, when it was desired to automatically record telegrams with such a detector, it was formerly necessary to employ a photographic method with the aid of a galvanometer. With the sound intensifier of the TELEFUNKEN Co., however, as long as the essential requirements of constant and sufficiently high discharge frequency in the transmitter ("tone transmitter") are filled, it is possible to use the more convenient MORSE recorder.

The connections²⁷³ for this purpose are sketched in Fig. 362. The microphone current of the third amplifier (*III* in Fig. 352) consisting of D.C. with superimposed A.C., instead of being led directly to the loud-speaking telephone (*LT*, Fig. 352), is sent through a small transformer, *TF* (Fig. 362), by way of the throw-over switch, *U*. A pure alternating e.m.f. is induced in the transformer secondary. In the secondary circuit, however, is a rectifier, *V*, so that current flows through it and

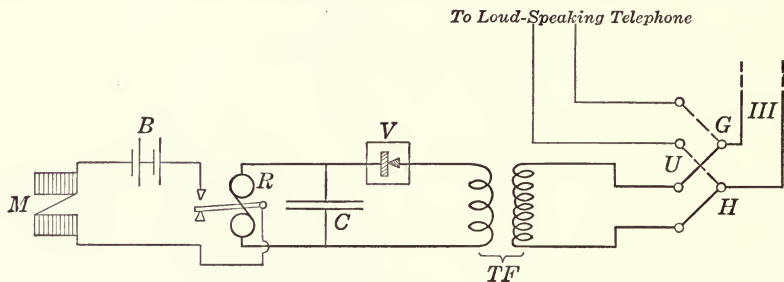

FIG. 362.

through the relay, *R*, in *one* direction only. This unidirectional current, however, is strong enough to actuate the polarized relay.

168. Recording Apparatus for the Metallic Granular Coherer.—The recording devices described in what has preceded, suffice for wave indicators which are self-restoring, but not for the metallic granular coherer. The latter, if connected with one of these devices, would become conductive at the first oscillation and remain so indefinitely; the relay in circuit with the coherer would then remain closed and the record would be a continuous straight line.

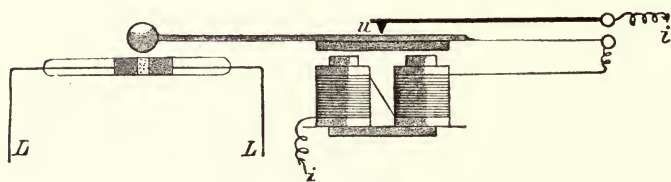

FIG. 363.

a. Hence, it is absolutely necessary to have a so-called "tapper" to restore the coherer to its normal condition after each oscillation or wave train. As is evident from the diagram of Fig. 363, the construction of the tapper is simply that of the ordinary electric bell or buzzer.

In the method of connection shown in Fig. 364,* which represents a standard coherer receiving outfit, current flows through the coherer immediately before it is tapped. As soon as the tapper strikes the

* E_1E_2 are galvanic cells, *K* is the tapper, *R* the relay, UU_1 the "make and break" contact of the relay, *M* the MORSE recorder, *W* a bell or sounder. *P* is a throw over switch for cutting in either the MORSE recorder, *M*, or the sounder, *W*.

coherer, this current is interrupted within the coherer. In spite of all precautions [see *b*], this will be accompanied by minute sparking which causes deterioration of the granules; this tends to prevent easy restoration of the coherer and to reduce its life or duration of usefulness. To meet this difficulty, the TELEFUNKEN Co. and others arranged the tapper so as to open the coherer circuit just before striking the coherer, so that the tapping always occurs at zero current.

b. In the method of connection shown in Fig. 364 there are three places where circuits containing coils wound on iron cores, *i.e.*, having high self-induction, are opened. Hence, quite high potentials arise and

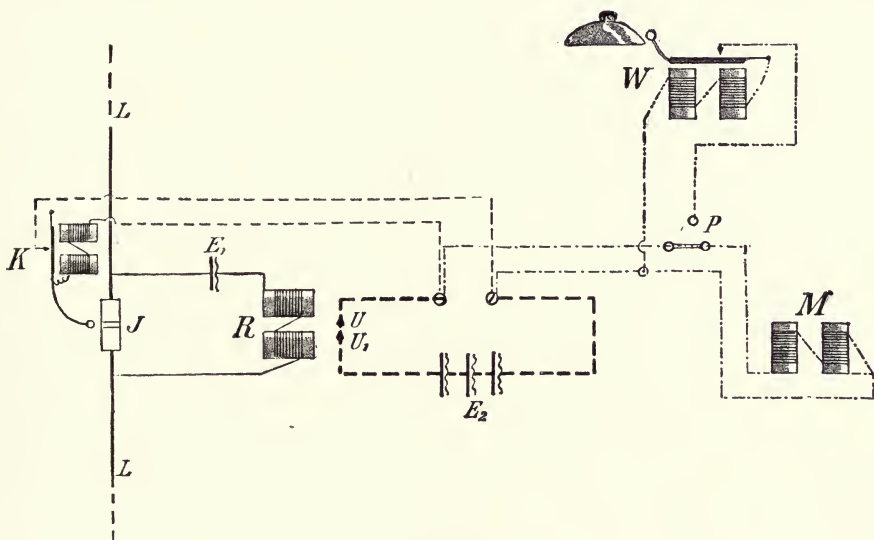

FIG. 364.

sparks occur at the points of interruption. This may result in the formation of electromagnetic waves which act upon the wave indicator. But even if this does not occur, the interruption of the relatively large currents may induce an e.m.f. in the circuit of the wave indicator, sufficient to cause the latter to respond to it.

This difficulty is usually avoided or minimized by placing in parallel with the break in the circuit and with the iron-core windings, *non-inductive resistances* [as, *e.g.*, *w* in Fig. 359] of suitable ohmic value or *polarized cells* (*e.g.*, two platinum wires as electrodes in diluted sulphuric acid), or also condensers of proper size, sometimes in conjunction with non-inductive resistances.

169. Call Signals.—When it is desired to transmit a message instantly and perhaps to obtain an immediate reply (as in military work), it is essential to have some method of calling the receiving station. This is also of great importance when ships at sea are in danger. Otherwise, for

ordinary radio-traffic, a call signal is not absolutely essential. Moreover there are recording receivers so arranged that their clockwork is automatically started when a telegram arrives and stops as soon as the telegram is completed.*

a. Where a relay is provided to operate the MORSE recorder, it is comparatively a simple matter to connect an electric bell (*W* in Fig. 364) as a call signal.

b. However, when the use of a relay is objectionable or undesirable in view of its added complication to the equipment, so that a simple telephone receiver is used, the problem is somewhat different. The TELEFUNKEN Co. has found a simple solution for it²⁷⁷ as follows: A moving coil galvanometer of high sensitiveness,† whose coil and the pointer connected thereto are *very sluggish*, is placed in the detector circuit. When the pointer deflects up to a certain angle, it runs into a contact wheel which is turned by a small clockwork and which holds the pointer fixed. This closes a circuit containing the call bell and a battery, so that the bell rings until the operator at the receiving station breaks the contact. The sluggish motion of the movable coil and pointer makes it necessary for the transmitting station to send out a long dash lasting say 10–12 seconds, during which time the transmitter continues to send out waves having a cumulative action upon the galvanometer. This prevents atmospheric disturbances of short duration from actuating the call signal and unnecessarily calling the station operators to the receiver.

170. Comparison of the Different Kinds of Detectors.—*a.* The main points to be considered in determining the practical usefulness of various detectors are as follows:

1. Sensitiveness.
2. Reliability in operation.
3. Simplicity in operation.
4. Simplicity of the necessary auxiliary apparatus.
5. Possibility of using a call signal.
6. Possibility of using a recording receiver.
7. Rapidity of telegraphing attainable.

b. As to the *sensitiveness*, a practical consideration of particular importance is whether the action of a series or sequence of successive waves (wave trains) is cumulative or not [Art. 163].

This is not the case with the metallic granular coherer. As it is customary in modern practice to work with a relatively high discharge frequency and relatively low energy per discharge, this alone has been sufficient to displace the coherer from practical use.‡

* The use of such automatic recorders is greatly limited in wireless telegraphy, as atmospheric disturbances constantly actuate the clockwork.

† 1 scale division = 10^{-7} amp.

‡ Except in certain special cases [e].

c. To this, however, is added another undesirable property of the coherer. It seems that with the carbon and graphite coherers, as well as with the metallic granular coherers, the reliability or certainty of operation becomes greatly reduced as the sensitiveness is increased, a change which is not nearly so marked in other wave indicators. Operators have always suffered from the capriciousness, one might say, of any very sensitive coherers.

High *sensitiveness* is of practical value only when combined with sufficient *reliability* in operation. Little can be stated on this subject as to the various wave indicators, as this depends not merely upon the particular type of indicator, but to a great extent upon the care taken in the construction of the individual indicator.

Non-sensitiveness to mechanical *jarring* and above all to momentary *overloading* caused by atmospheric disturbances or the proximity of a powerful transmitter is essential to reliability. Accordingly, wave indicators having a point contact, as, *e.g.*, certain of the thermal detectors, are dangerous in both respects, while electrolytic detectors like that of SCHLÖMILCH are non-sensitive to jarring, but very sensitive to overloading.

d. *Operation* is simplest with those detectors which, when once adjusted, require no further regulation (some of the crystal detectors, magnetic detectors, incandescent lamp detectors). Wave indicators, whose sensitiveness depends largely upon the pressure at the point of contact, are apt to require frequent readjustment.* For this skilled operators are needed and it is often the cause of poor service.

As to the handling of the receiving apparatus, the use of a polarized relay involves considerable skill and care in making the adjustment and readjustments. In this respect the photographic recording receivers have the advantage; but with these, the string of the EINTHOVEN galvanometers requires equally careful adjustments.

e. As to *simplicity* of the receiving apparatus, it is evident that receivers involving any moving parts operated by clockwork are at an inherent disadvantage. MARCONI'S magnetic detector has the additional disadvantage of occupying a large amount of space, which however is not so important in large land stations.

The number of necessary apparatus, however, aside from the case of the coherer, which is disadvantageous from this viewpoint also, depends not so much upon the type of wave indicator as upon the object in view. If only telephonic reception is desired, the apparatus becomes as simple as possible, but recording the messages and using a call signal always

* The fact that readjustment for maximum sensitiveness is *possible* with these wave indicators comprises an advantage from another point of view. For those indicators in which such readjustment is impossible may become worthless after a sufficiently severe atmospheric disturbance.

complicates the receiving apparatus, no matter what kind of a wave indicator is used.

The *great simplicity* and *sensitiveness* of the telephone receiver explains why this has become the rule, the recording receiver the exception, even though the latter has certain decided advantages. The sensitiveness and reliability of telephonic reception is largely dependent upon psychological factors in the operator and is easily interfered with by external noises;*²⁷⁸ the reliability of a recording receiver depends only upon the excellence of the apparatus and it always furnishes a positive document of the received message.

f. Formerly the *possibility of applying a call signal* and a recorder drew sharp lines between the various wave indicators. This distinction, however, has gradually disappeared. The method of calling [Art. 169] introduced by the TELEFUNKEN Co. seems to be adaptable to nearly all wave indicators of practical value. And as to recording received messages, there appear to be two methods applicable to all wave indicators, either by means of an EINTHOVEN galvanometer (photographic recording) or by means of the TELEFUNKEN sound intensifier, which latter, however, presupposes tone transmission.

g. All the various wave indicators and recording devices are capable of responding to the *speed* of telegraphing obtainable by *manual* operation of the transmitting key or relay key. With the high speeds attained by means of automatic keys and rapid telegraph devices [Art. 117c], the use of the metallic granular coherer, which involves the setting into operation of a series of mechanical apparatus is of course out of the question. So far as the author knows, the limit of permissible speed in transmission has not been reached with any of the other wave indicators used in practice.

However, the limitation in the permissible speed of transmission is encountered in the *recording receivers*, particularly in the EINTHOVEN galvanometer (photographic) method, which seems to have responded to the highest speeds† used.

* On airships, aeroplanes, etc., the attendant noises make telephone reception very difficult. For this reason the coherer has been returned to in some instances, in conjunction with a relay controlling the circuit of a small incandescent lamp. Relatively short and longer periods of incandescence in the lamp represent dots and dashes.²⁷⁸ However, telephone reception has also been used with considerable success on flying machines.

† The rapid telegraph apparatus of P. O. PEDERSEN, operating between the POULSEN stations at Lyngby and Esbjerg, is said to have attained a speed of 300 words per min.; the normal speed of the POULSEN stations is given as 150 words per min. (The CULLERCOATS station transmits 200 words per min. over a distance of 800 km.) A speed of 100 words per min. has been achieved with MARCONI apparatus; the transatlantic MARCONI stations are said to operate at "quelques dizaines" words per minute.

CHAPTER XII

RECEIVERS

171. The Aerials at the Receiving Stations.—The waves sent out by a transmitter result in an electromagnetic alternating field, which may be a rotating field, at the location of the receiver. Consequently if a conductor is placed within this field oscillations are generated in it.

The conductor for this purpose is the *antenna*, which also serves for transmitting, a complete station being equipped for both sending and receiving, just as in ordinary wire telegraphy. Usually a throw-over switch is provided for connecting the aerial either to the transmitter or to the receiver, as may be desired; otherwise, it is arranged that the receiver is automatically connected to the aerial whenever the station is not transmitting.²⁸⁰

Following a suggestion of O. SQUIER,²⁸¹ *trees* have been successfully used as receiving aerials for distances of about 50 km. The method is to hammer a nail into the tree a few yards above the ground and to connect the receiving apparatus between the nail and the ground.

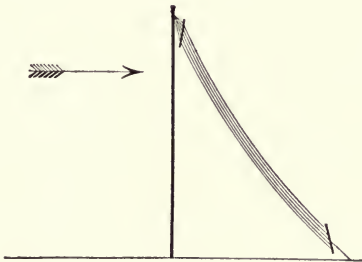

FIG. 365.

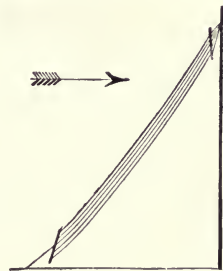

FIG. 366.

As to the *direction* of the aerial, it is advantageous to have this the same as the direction in which the electric field has its greatest amplitude. This depends upon the ground on which the station stands. In the one limiting case (namely, sea water), in which the field of the transmitted waves is a vertical alternating field (according to Art. 138), a vertical aerial is by far the best. In the other limiting case, with the station standing on dry ground, the direction in which the amplitude of the electric field is a maximum is apt to be at a considerable angle to the vertical (Art. 139, *et seq.*); hence an aerial inclined in the direction shown

in Fig. 365 (arrow indicates direction of wave propagation) is materially more efficient than a vertical aerial or one inclined as that of Fig. 366.*

172. General Consideration of the Receiving System.—*a.* The electric field surrounding the receiving antenna produces an e.m.f., \mathcal{E} , along its length. This e.m.f.¹⁶³

$$\mathcal{E} = E \cdot \alpha_2 h_2 = E h'_2 \quad (1)$$

where E is the component of the transmitted field strength in the direction of the aerial, h_2 the total and h'_2 the effective height of the aerial, α_2 being its form factor [Art. 100c].

Consequently this e.m.f. for a given field, *i.e.*, for the same transmitter, increases as the height and the form factor of the antenna are increased. In this respect, therefore, great height and large form factor offer the same advantages as for transmission; moreover, antennæ which radiate freely are also advantageous for reception in this respect.

b. However, from another standpoint high radiation is a disadvantage for reception; for, as soon as the receiving antenna begins to oscillate it radiates energy at a rate which increases as the radiation resistance increases. This radiated energy is lost to the receiver, which can make use only of such energy as is carried over to the detector.

The conditions²⁸² existing in the receiving antenna are similar to those in any oscillator acted upon by an external e.m.f. [Arts. 56 and 67]. If the oscillator is tuned to the frequency of the external e.m.f.—which is the only case we need consider in practice—it will oscillate at its natural frequency, the amplitude of the oscillations growing constantly until the point is reached where the energy consumed in the receiver during one period = the energy supplied to it by the external e.m.f. (the transmitter) during the same period. Hence the maximum amplitude decreases as the energy consumption increases and therefore also as the radiation resistance of the antenna is increased.

With undamped oscillations [Art. 67*b*] the current I_2 in the receiver is given by

$$I_2 = \frac{\mathcal{E}}{R_2}$$

R_2 being the total resistance of the receiving antenna. Consequently the heat developed in a detector of resistance R_d (or in a detector circuit [Art. 175] of equivalent resistance R_d [Art. 55c]) is

$$R_d \cdot I_2^2_{eff} = \frac{R_d}{2(R_d + R'_2)} \cdot \mathcal{E}_0^2$$

* Assuming the same constants as those on which Fig. 303 (page 254) is based, the aerial of Fig. 365, if brought to a vertical position would reduce the amplitude by 18 per cent. and if brought to the position of Fig. 366 would cause a reduction of about 66 per cent. (see the inclined aerials discussed in Art. 205).

(R'_2 = effective resistance of the antenna without the detector). If the transmitted oscillations are damped (decrement = d_1) it follows from Art. 70, by substituting $\frac{R_2}{2NL_2}$ [Art. 8d] for d_2 therein, that

$$R_d \cdot I_{2_{eff}}^2 = \frac{R_d}{(R_d + R'_2)^2} \cdot \frac{\zeta}{4N} \cdot \frac{1}{d_1 \left(1 + \frac{d_1}{d_2}\right)} \cdot \varepsilon_0^2$$

Now let us assume that the receiving antenna is so well constructed that the (JOULEAN) heat loss in its wires and in the ground is negligible compared to the radiation losses. Then $R'_2 = R_\Sigma$.

Moreover, let the detector resistance be at its *best value*, i.e., the value at which the heat developed within the detector and hence also the *range* are at their *maximum*. With undamped oscillations this value is R'_2 ; with damped oscillations it would be $\tau R'_2$, where τ is somewhere between 1 and 2 for all important conditions encountered in practice. (If the transmitting and receiving antennæ as well as the ground conditions at both points are the same, $\tau = \sqrt{2} = 1.41$.)

Then the heat developed, $R_d I_{2_{eff}}^2$, with undamped oscillations is

$$\frac{1}{8R_\Sigma} \cdot \varepsilon_0^2$$

and with damped oscillations is

$$\frac{\tau}{(1 + \tau)^2} \cdot \frac{1}{R_\Sigma} \cdot \frac{\zeta}{4N} \cdot \frac{1}{d_1 \left(1 + \frac{d_1}{d_2}\right)} \cdot \varepsilon_0^2$$

Substituting for R_Σ its value from Art. 100c and for ε its value from equation (1), we obtain for the heat developed in the detector with undamped oscillations,

$$\frac{1}{8 \times 16\pi^2 \cdot \frac{(\alpha_2 h_2)^2}{\lambda^2} \times 10^{10}} \cdot (\alpha_2 h_2)^2 E_0^2 = \frac{1}{128\pi^2 \times 10^{10}} \cdot \lambda^2 \cdot E_0^2 \text{ c.g.s. units,}$$

and with damped oscillations

$$\begin{aligned} & \frac{\tau}{(1 + \tau)^2} \cdot \frac{1}{16\pi^2 \times 10^{10}} \cdot \frac{\zeta}{4N} \cdot \frac{1}{d_1 \left(1 + \frac{d_1}{d_2}\right)} \cdot \lambda^2 \cdot E_0^2 \\ &= \frac{\tau}{(1 + \tau)^2} \cdot \frac{1}{16\pi^2 \times 3 \times 10^{20}} \cdot \frac{\zeta}{4} \cdot \frac{1}{d_1 \left(1 + \frac{d_1}{d_2}\right)} \cdot \lambda^3 \cdot E_0^2 \end{aligned}$$

Accordingly the greatest heat development attainable in the detector is entirely independent of the form and height of the antenna with undamped oscillations and is affected only very slightly, namely, through the value $\frac{d_1}{d_2}$, by these factors in the case of damped oscillations. It is increased, however, as the wave-length of the oscillations increases.

c. Maximum heat development in the detector is a requirement for obtaining maximum range. The resultant increase in the decrement of the receiver may, however, be undesirable from other viewpoints (as for sharp tuning). Hence the energy consumed in the detector is usually left considerably below the possible maximum.

Assuming it to be so low that $R_d \ll R_\Sigma$, then from *b* we obtain that for undamped oscillations

$$R_d I_{2\text{eff}}^2 = \frac{R_d}{R_\Sigma^2} \cdot \epsilon_0^2 \text{ approximately}$$

and for damped oscillations

$$R_d I_{2\text{eff}}^2 = \frac{R}{R_\Sigma^2} \cdot \frac{\zeta}{4N} \cdot \frac{1}{d_1 \left(1 + \frac{d_1}{d_2}\right)} \cdot \epsilon_0^2 \text{ c.g.s. units;}$$

or, for undamped oscillations

$$R_d I_{2\text{eff}}^2 = \frac{R_d}{2(16\pi^2 \times 10^{10})^2} \cdot \frac{\lambda^4}{(\alpha_2 h_2)^2} \cdot \epsilon_0^2 \text{ c.g.s. units}$$

and for damped oscillations

$$= \frac{R_d}{(16\pi^2 \times 10^{10})^2} \cdot \frac{\zeta}{4 \times 3 \times 10^{10}} \cdot \frac{1}{d_1 \left(1 + \frac{d_1}{d_2}\right)} \cdot \frac{\lambda^5}{(\alpha_2 h_2)^2} \cdot E_0^2 \text{ c.g.s. units.}$$

In this case an antenna of low height and low form factor is at a great advantage and the importance of long wave-length becomes very marked (R. RÜDENBERG¹⁶³).

d. Nevertheless we must remember that the discussions in *c* and *b* take only incomplete consideration of the influence of the wave-length, in that the *receiver* only is considered. If we take the *transmitter* into account as well, the conditions become altered.

According to Art. 138*c* and the second foot-note in Art. 139*c*

$$E_0 = 12\pi \times 10^{10} \frac{\alpha_1 h_1}{\lambda} \cdot \frac{e^{-\beta r}}{r} I_{1_0}^*$$

Substituting this value in the equations obtained above, the heat development in the case of *maximum range* ($R_d = R_\Sigma$ and $R_d = \tau R_\Sigma$ resp.) becomes

$$\frac{9}{8} \times 10^{10} \cdot (\alpha_1 h_1)^2 \cdot \frac{e^{-2\beta r}}{r^2} \cdot I_{1_0}^2$$

for undamped oscillations, and

$$\frac{\tau}{(1 + \tau)^2} \times 3 \cdot \frac{\zeta}{4} \cdot \frac{1}{d_1 \left(1 + \frac{d_1}{d_2}\right)} \cdot (\alpha_1 h_1)^2 \cdot \frac{e^{-2\beta r}}{r^2} \lambda I_{1_0}^2$$

* α_1 = form factor and h_1 = height of transmitting aerial; β = coeff. of absorption [Art. 139*b*] + stray field coeff. [Art. 140*b*]; I_{1_0} = current amplitude at base of transmitting aerial.

for damped oscillations; while in the case of the *best possible sharpness of tuning* ($R_d \ll R_\Sigma$) these values become

$$\left(\frac{3}{4\pi}\right)^2 \cdot \frac{R_d}{2} \cdot \left(\frac{\alpha_1 h_1}{\alpha_2 h_2}\right)^2 \cdot \lambda^2 \cdot \frac{e^{-2\beta r}}{r^2} \cdot I_{1_0}^2$$

for undamped oscillations, and

$$\left(\frac{3}{4\pi}\right)^2 \cdot R_d \left(\frac{\alpha_1 h_1}{\alpha_2 h_2}\right)^2 \cdot \frac{\zeta}{4 \times 3 \times 10^{10}} \cdot \frac{1}{d_1 \left(1 + \frac{d_1}{d_2}\right)} \cdot \lambda^3 \cdot \frac{e^{-2\beta r}}{r^2} \cdot I_{1_0}^2$$

for damped oscillations.

In the first case (maximum range) long wave-length with undamped oscillations is important only in that it is advantageous in regard to absorption [Art. 139f] and stray field [Art. 140].

In the second case (maximum tuning sharpness), however, long wave-length offers considerable additional advantages. Moreover in this case the *combination of a freely radiating transmitting aerial with a weakly radiating receiving aerial* would be materially superior to two similar aerials.

e. According to d , with damped oscillations of constant frequency, the current effect in the receiver $\propto \frac{I_{1_0}^2}{d_1 \left(1 + \frac{d_1}{d_2}\right)}$. The current effect $I_{1_0}^2_{eff}$ at

the base of the transmitting antenna $\propto \frac{I_{1_0}^2}{d_1}$. Hence the current effect in

the receiver $\propto \frac{I_{1_0}^2_{eff}}{1 + \frac{d_1}{d_2}}$.

It follows that, in making long distance tests "under the same conditions," it is essential that not only the current effect at the base of the transmitting antenna but also the decrement of the transmitter oscillations remain constant. *It is not sufficient to simply keep the current effect at the base of the transmitting antenna constant.*

1. THE ORIGINAL MARCONI RECEIVER

173. The First Arrangement.—*a.* Fig. 367 shows the simple arrangement used by MARCONI in his first experiments. It is the exact counterpart of the original transmitter shown in Fig. 209, the spark gap of which is replaced by the wave indicator, which, in the original MARCONI equipment, was a metallic granular coherer.

This arrangement, even if the coherer were replaced by, say, a thermal detector of very high resistance, would have the great disadvantage of too great resistance in the receiver and too large a decrement in the

receiving antenna. If the equations of Art. 172 are applied to this case,* in which $R_d < R'_2$, we obtain approximately for undamped oscillations:

$$R_d I_{eff}^2 = \frac{1}{2R_d} \epsilon_0^2$$

and for damped oscillations

$$R_d I_{eff}^2 = \frac{1}{R_d} \cdot \frac{\zeta}{4N} \cdot \frac{1}{d_1} \cdot \epsilon_0^2$$

i.e., the greater the resistance of the detector, the less heat will be developed in it.

Moreover, to the high resistance of the metallic granular coherer, there is added the difficulty that when unexcited it has a capacity effect, while when excited, it is simply a very high resistance. Hence the receiving antenna if tuned to the transmitter in one condition, can not be tuned for the other.

The arrangement of Fig. 367 had still another disadvantage: It was easily affected by atmospheric disturbances. If the portion of the antenna above the coherer, through which it is insulated from ground, obtained only a slight static charge, this brought its potential difference with the earth sufficiently high to break through and excite the coherer.

174. The Marconi Transformer.— This last-mentioned difficulty was what chiefly induced MARCONI to soon remove the coherer from the aerial.

He replaced it with a coil, S_1 , and caused the latter to act inductively upon another coil, S_2 , having a much greater number of turns and the ends of which were connected to a coherer (Fig. 368).† The transformer ($S_1 S_2$) thus formed by these two coils was called the "jigger."

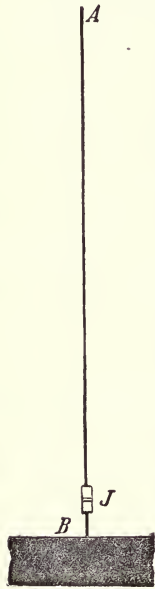

FIG. 367.

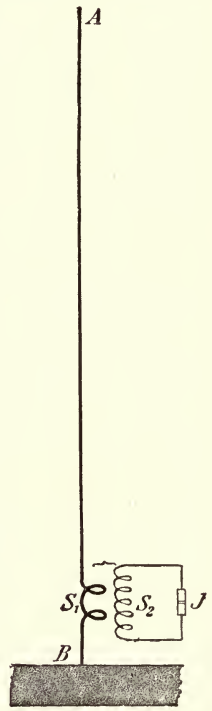

FIG. 368.

a. Not only does this arrangement provide a direct path to ground for static charges in the aerial, but the damping of the antenna retains its normal value and is not appreciably altered by the changes in the coherer. Consequently the oscillations of the antenna may rise to a much greater amplitude. When the coherer is excited by the oscillations induced in S_2 , a closed circuit $S_2 J$ is formed. A large part of the energy in the antenna is then transferred to this

* Assuming that natural oscillations of the antenna are still possible.

† But see *c* of this article.

circuit S_2J , and the heat thereby developed in the coherer so reduces the latter's resistance that the relay responds.

b. There is another point to be considered. With the coherer directly in the aerial, the use of multiple antennæ gained nothing over the simple antenna. The use of several wires instead of a single aerial wire did not increase the potential across the coherer terminals, and the greater current amplitude, obtainable with the multiple aerial, did not help the coherer much. Now, however, it became possible to make use of the increased current amplitude of the multiple antenna, for with the transformer the increased current could be used to produce much higher potentials across the coherer than would be obtained in the antenna itself.

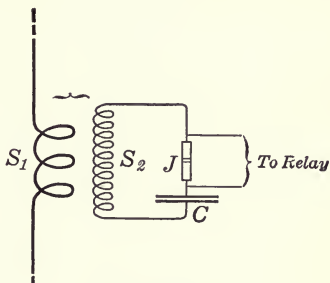

FIG. 369.

To be sure, these advantages can only be secured if the antenna is tuned to the transmitter oscillations and the secondary circuit ($S_2 +$ coherer in unexcited condition*) is tuned to the antenna. The importance of just this requirement was probably not recognized at the time; however, the fact that the entire arrangement operates satisfactorily

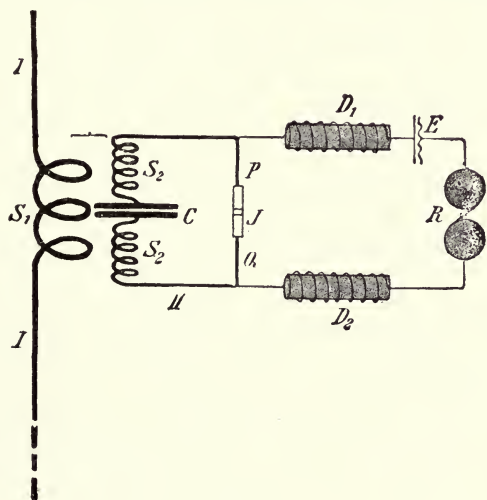

FIG. 370.

only if certain requirements are filled, was recognized and pointed out by MARCONI from the first. The requirements were met by trying out in each station what was the best form of the transformer, which as a matter of fact consisted primarily in adjusting the primary and secondary frequencies (and perhaps also the degree of coupling).

c. The arrangement of Fig. 368 can not be used just as shown there; for the coil S_2 would close the relay circuit (see Fig. 359) even when the

coherer was in its non-conducting state. This is prevented by inserting a block condenser, C , (Fig. 369 or Fig. 370), which has no appreciable effect upon the oscillations if its capacity is sufficiently great [Arts. 30c and 41c].

* The latter was not so essential, as a very close coupling was used.

2. RECEIVERS FOR TUNED TELEGRAPHY WITH DAMPED OSCILLATIONS

The main object of tuned telegraphy is to have the receiver respond only to waves of a certain frequency (wave-length) and not at all, or at any rate only very slightly, to waves of any other frequency (wave-length).*

The solution of this problem varies according as the receiving antenna is highly or slightly damped.

175. Receivers for Highly Damped Receiving Antennæ.—Such receivers are always constructed as to have a *slightly damped secondary circuit coupled to the primary (antenna) circuit*. The detector may be in the secondary circuit or it may be in either a condenser circuit or a closed circuit (**detector circuit**) coupled to the secondary circuit.

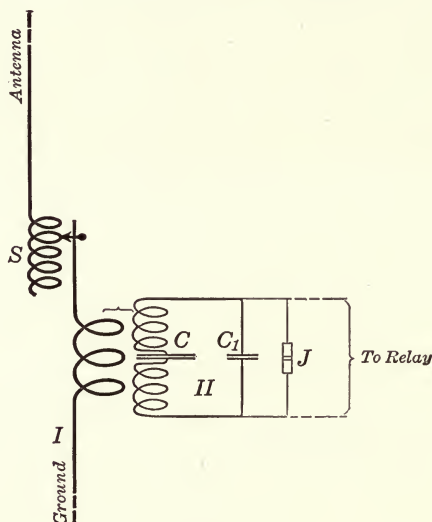

FIG. 371.

All these circuits are tuned to the transmitted frequency and hence are in resonance with one another.

The following are a few of the many arrangements which are or have been in use, many of them being very similar in principle.

a. Condenser Circuit Secondary; Inductive Coupling with the Aerial.—This arrangement was used by MARCONI and with it he first demonstrated the possibility of tuned telegraphy.†

It is shown diagrammatically in Fig. 371. Condenser *C* serves as a

* This condition is more or less obtainable by simply loosening the coupling between S_1 and S_2 in the arrangements of Figs. 369 and 370 [see Art. 180*d*]; in fact these connections were used by MARCONI for tuned telegraphing.

† Probably the first proposal to use tuned telegraphy was that of O. LODGE (Brit. Patent 11575 of 1897, applied for May 10, 1897). In this patent some of the requirements which an arrangement for tuned telegraphy must fill are clearly stated. LODGE, however, does not seem to have had any practical success until MARCONI completed his first successful experiments in tuned telegraphy.

block condenser; as it has much greater capacity than condenser C_1 , to whose terminals the coherer F is connected, the latter, C_1 (in conjunction with the coherer in parallel) determines the fundamental frequency of the condenser circuit [Art. 4b].



FIG. 372.

Of late, the MARCONI Co. makes use of a special tertiary circuit for the detector in its commercial stations. This so-called "multipletuning apparatus" of the MARCONI Co. is shown in Fig. 372.* The variable condenser at the upper left hand and the self-induction adjustable in steps below the condenser, serve for tuning the aerial. The variable condenser in the middle is part of the secondary or intermediate circuit, while that at the upper right belongs to the detector circuit. The self-induction of these two (secondary and tertiary) circuits is adjusted to the same step in both simultaneously.

b. Condenser Circuit Secondary; Direct Coupling between Aerial and Condenser Circuit.—This arrangement was used by LODGE and MUIRHEAD²⁸³ with the granular coherer and by the TELEFUNKEN Co. (see diagram of connections, Fig. 373) with the SCHLÖMILCH detector, when particularly sharp tuning was desired.

The TELEFUNKEN Co. used a special tertiary condenser circuit (III, Fig. 373), as proposed by F. BRAUN,²⁸⁴ containing the effective condenser C_2 and the block condenser of large capacity, C .

* Courtesy of the MARCONI Co.

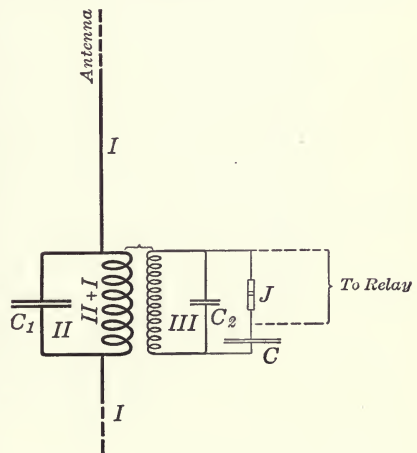

FIG. 373.

Fig. 374 illustrates a TELEFUNKEN receiver for thermal detectors on this same principle. The primary inductance ($I + II$ in Fig. 373) is divided into two parts. One part (marked "4" in Fig. 374) is coupled to the condenser circuit III (Fig. 373) containing the detector, while the other part (at the upper right hand in Fig. 374 and marked "EA") con-

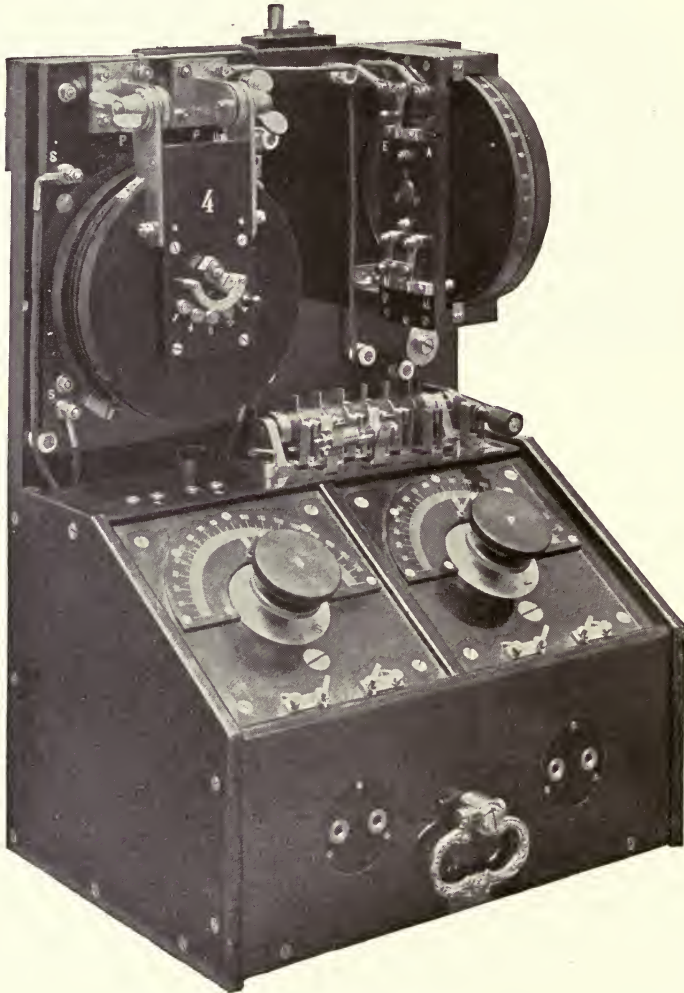

FIG. 374.

sists of a coil of variable self-induction (RENDAHL variometer). The condensers (P , Fig. 374 = C_1 , Fig. 373 and S , Fig. 374 = C_2 , Fig. 373) are variable plate condensers.

The results obtained with the connections shown in Fig. 373 depend very largely on the relative amount of self-induction in I and II as com-

pared with the effective self-induction of the rest of the antenna and of the "lengthening" or "loading" coils in it. If the self-induction of I and II is relatively small, as was the case in what has just preceded, the primary circuit must be considered as: Aerial, coils I and II , ground; while the secondary would be comprised of the condenser circuit C_1 , coil $I + II$. But if the self-induction of coils I and II is relatively large, we have a case of the "fly-wheel" system, described in Art. 98b, applied to the receiver. The primary circuit then consists of the condenser circuit comprised by the inductance $I + II$ (Fig. 373) and the capacity formed by the condenser C_1 in parallel with the capacity antenna-ground.

c. Single Coil Secondary.—With this arrangement, in which the natural oscillations of coils [Art. 23] and not of condenser circuits is employed, A. SLABY and COUNT ARCO, following soon after MARCONI, succeeded in obtaining a tuned radio-telegraph system. It is now no longer in use.

176. Receivers for Weakly Damped Antennæ.—If the decrement of the antenna is not much different from that of a well designed con-

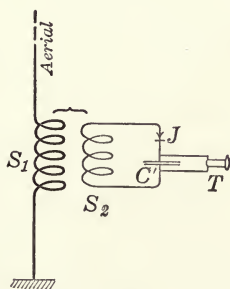

FIG. 375.

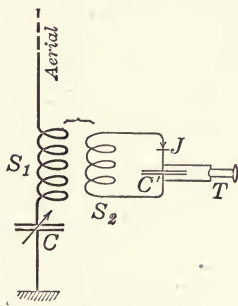

FIG. 376.

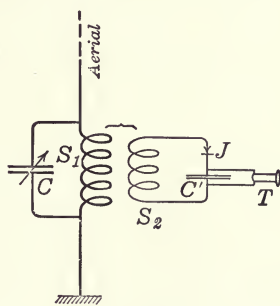

FIG. 377.

denser circuit without spark gap, then the use of a condenser circuit as secondary no longer offers the same advantages as with a strongly damped antenna [Art. 180d].

Hence, in this case, which applies to all quenched spark operation, the antenna is coupled to a *closed* detector circuit²⁸⁵ containing the detector as shown in Fig. 375.* The coupling may be either inductive (Fig. 375) or conductive (Fig. 378).

The TELEFUNKEN CO.¹⁶⁰ has applied this method of connection for use with transmitters arranged for two standard wave-lengths in the following manner. An inductance S_1 (Figs. 376 and 377) is always left in the receiving antenna, in which there is also a condenser C . When the transmitter is working on the short wave, S_1 and C are placed in series (Fig. 376), while for the longer wave they are connected in parallel (Fig. 377). In the latter case we again have the "fly-wheel" connection

* C' is simply a *block* condenser of great capacity.

[Art. 98*b*]. A receiver built on this principle is shown in Fig. 236 (marked "33"); *C* is a variable plate condenser by means of which the receiving antenna can always be exactly tuned to the transmitted oscillations.

177. Tuning the Receiver for a Double Wave Transmitter.—In Arts. 175 and 176 it was tacitly assumed that the transmitter furnished a wave of only *one length*. This is the case with the WIEN transmitter, but is true of the BRAUN transmitter only if the coupling between the primary and secondary circuits is very loose.

If the coupling in the BRAUN transmitter is not very loose, two waves of different length are obtained. The question then at once suggests itself: Which wave shall the receiver be tuned for?^{285a}

This question is justified from two standpoints, viz.:

a. There is, firstly, the question *per se* as to whether it is better to tune the receiver for the longer or for the shorter wave. In Art. 106*a*, the reasons in favor of the shorter wave-length (higher frequency) were discussed. On the other hand, the fact remains that the shorter wave is more rapidly absorbed in the daytime than the longer wave [Art. 139*f*] and that, moreover, the longer wave is more efficient in regard to producing useful energy consumption in the receiver [Art. 172*b*]. As a matter of fact, however, it is *universal practice to tune for the shorter wave*, so far as the author knows.

b. Secondly, there may be some question whether it is best to have the receiver tuned exactly for the wave-length to which it should respond.

If the receiver consisted of a single, slightly damped system, then [see Art. 87*a*] a certain definite small displacement from exact resonance (*i.e.*, a slight dissonance) between the receiver and the transmitter oscillations should give the best results, at least in case the transmitter is quite loosely coupled so that its two waves are nearly of the same frequency. Even if the receiver consists, not of a single, but of two or three loosely coupled circuits or systems, it is very probable that the same holds true. Accordingly, it is not unreasonable that, with a not very closely coupled transmitter a slight displacement from resonance may be advantageous, or, to put it more correctly, that well adjusted receiving stations really operate at a point slightly off exact resonance.

178. Adjustment of the Energy Delivered to the Receiver.—According to Art. 172, it is of great importance for the heat developed in the wave indicator and hence for the *range* of operation, that the energy delivered to the wave indicator has a distinct relation to the energy losses in the receiver. On the other hand, *maximum sharpness in tuning* [Art. 180] requires the lowest possible damping and hence minimum energy delivered to the wave indicator. Therefore, either one or the other requirement will be met according as the chief object in view is longer range or very sharp tuning. Or, otherwise, a compromise is made, the energy supply to the wave indicator being adjusted to give a good

range, without allowing the sharpness of tuning to fall below the desired practical limit.

The amount of energy delivered to the wave indicator is adjusted by varying the degree of coupling between the detector circuit and the antenna or the secondary circuit of the receiver.

Figs. 378 and 379* show the method of arranging a conductive coupling of the detector circuit† direct with the antenna in Fig. 378 and with the secondary circuit, ABC_1 , of the receiver in Fig. 379. The coupling is varied by means of the sliding contact Sc . As the portion A - Sc of

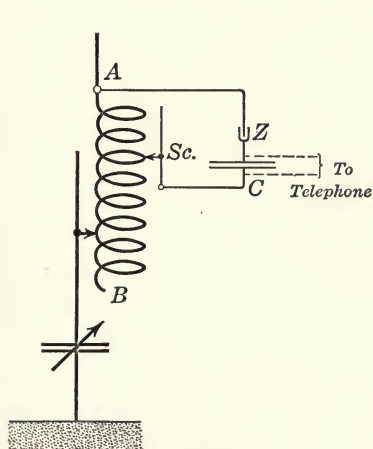

FIG. 378.

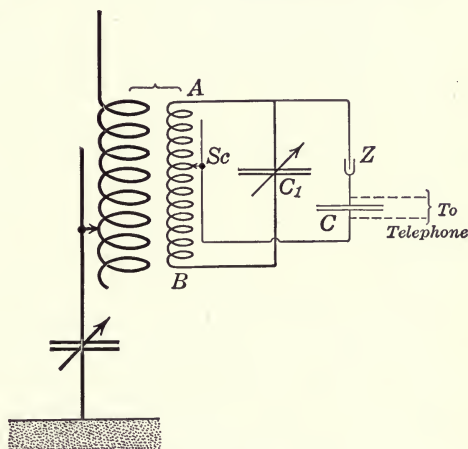

FIG. 379.

the coil AB is increased (or decreased), the current flowing through the detector Z and hence the action in the detector is increased (or decreased) while the damping is also increased (or decreased).

For inductive coupling of the detector circuit, the arrangements shown in Figs. 375-377 can be used if the coupling between S_1 and S_2 is variable [Art. 54].

179. Receivers for Two Different Detectors.—In receiving stations where two different wave indicators (say, one for telephone reception, the other for call signaling or for recording) are to be used, it usually does not suffice to simply install a throw-over switch for connecting either wave indicator to the rest of the apparatus. Aside from the fact that this would limit the reception to one of the wave indicators at a time, it is advisable to have separate secondary circuits adapted to the individual requirements of each indicator.

* This arrangement of circuits may be considered as dividing the current between the two parallel branches consisting of the self-induction A - Sc and the detector Z with its block condenser, C .

† These connections were used by the TELEFUNKEN Co., in conjunction with the electrolytic detector.

The arrangement used by the TELEFUNKEN Co. for this purpose and illustrated in Fig. 380 will serve as an example. It requires little or no further explanation; the "tuning coil" and the variable condenser *C* serve for tuning the aerial. Fig. 381⁸² shows the construction of the tuning coil, Figs. 382⁸² and 383⁸² are the coupling transformers for the recording and for the telephone receivers respectively, arranged for adjustable coupling.

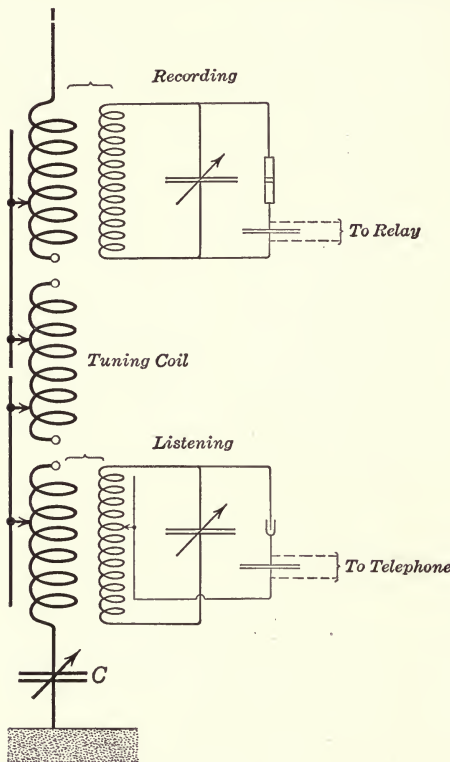

FIG. 380.

Fig. 384 shows the entire outfit assembled as a unit.

180. The Sharpness of Tuning.—If the frequency of the transmitter is changed, the effect upon the receiver will also change. Assume that a thermal wave indicator (*e.g.*, a thermocouple) is used in the receiver. Plot the deflections of the galvanometer in the circuit, which deflections are proportional to



FIG. 381.

the current effect in the detector, as ordinates and the different transmitter frequencies as abscissæ. The resulting "resonance curve of the receiver" will be of the form of the heavier curve in Fig. 385; the effect is a maximum at a certain transmitter frequency, N_0 , at which frequency the transmitter is said to be "in tune," while at any other frequency it is "out of tune."

If now the galvanometer is replaced by a relay, the latter will not respond below a certain current. Thus, let us assume that under the conditions represented by the heavy curve in Fig. 385, the current at resonance is $\frac{1}{10}$ milliamperes and that at least $\frac{1}{30}$ milliamperes is required to actuate the relay; then the relay will not respond at frequencies below $0.967 N_0$ or above $1.033 N_0$, *i.e.*, at a dissonance of more than 3.3 per cent. in the transmitter. This 3.3 per cent. is

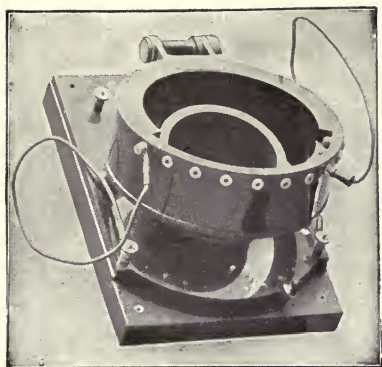

FIG. 382.



FIG. 383.

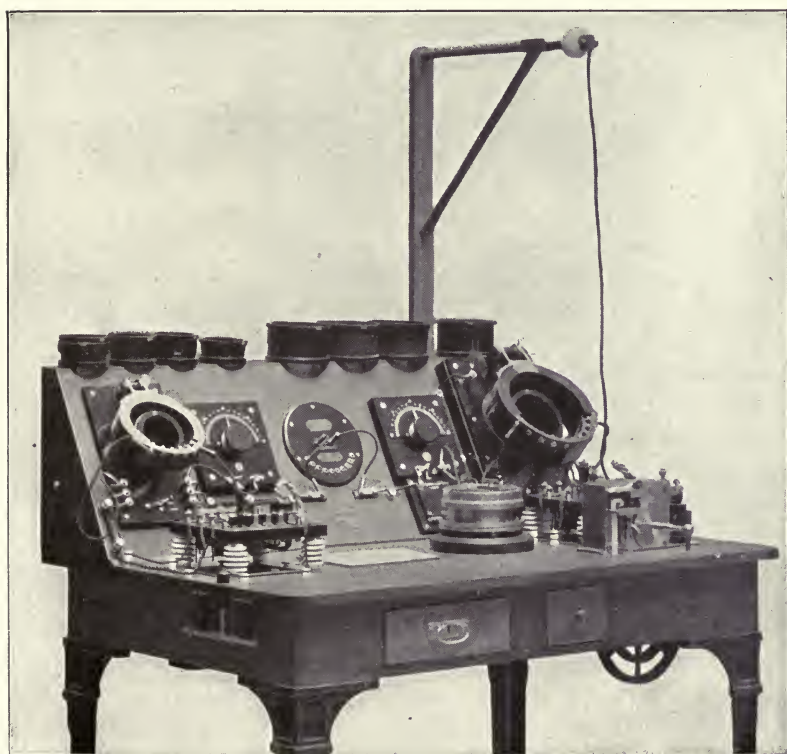

FIG. 384.

sometimes called the "necessary dissonance". Apparently, therefore, the "sharpness of tuning" varies inversely as the necessary dissonance.*

a. The sharpness of tuning depends upon two factors, viz.:

1. The shape of the resonance curve (Fig. 385) and hence upon the sharpness of resonance [Art. 70c].
2. The factor of safety [Art. 148] of the station.

The relation to the form of the resonance curve is evident from Fig. 385. The steeper the curve, the sharper is the resonance, and hence the sharper will be the tuning. Thus, if, *e.g.*, the resonance curve were the flatter, light curve in Fig. 385, then, under the same conditions as were

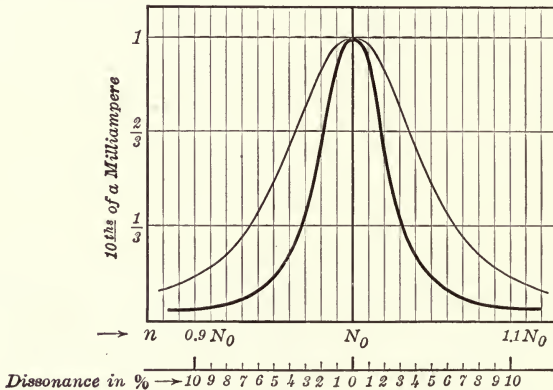

FIG. 385.

assumed previously, the necessary dissonance would be about 6.5 per cent., the sharpness of tuning correspondingly less.

As to the other factor which determines the sharpness of tuning, it was pointed out above that under the conditions assumed $\frac{1}{30}$ milliampere was required to make the relay respond. When the station is tuned, *i.e.*, under normal operating conditions $\frac{1}{10}$ milliampere is supplied to the relay. Hence the station has a working factor of safety of $\sqrt{3}$. If the working safety factor were lower, *e.g.*, $\sqrt{1.5}$, then under the conditions represented by the heavy line curve of Fig. 385 the relay would only respond within 2 per cent. of resonance, so that the tuning would be much sharper.

From the preceding it is evident that record tests giving very great sharpness of tuning must not be considered as conclusive. By adjusting a receiver so that the slightest deviation from resonance suffices to prevent the apparatus from responding as an indicator, the tuning appears to be, in fact really is, very sharp; but the station is entirely unfit for normal service.

* The best measure of the sharpness of tuning is the reciprocal of the necessary dissonance value.

b. As to the *form of the resonance curve*, this is easily determined for a receiver without secondary condenser circuit as used for weakly damped antenna oscillations. For if the conditions in the detector circuit are such that the current effect in it is proportional to that in the antenna [Art. 55b], then the resonance curve is exactly the same as that corresponding to a primary circuit of decrement d_1 in the transmitter and a decrement d_2 in the receiving antenna and is determined by the sum of the decrements of the transmitting and receiving antennæ. At the same time, the decrement of the receiving antenna of course depends also upon the amount of energy supplied to the detector.

The resonance sharpness and, hence, also the sharpness of tuning increase as the damping of the transmitter oscillations and that of the receiving antenna decrease.

c. The *resonance curve for receivers with secondary condenser circuit* is easily calculated if the transmitter oscillations are *undamped* and if the primary and secondary circuits of the receiver are very loosely coupled. In this case, in a very short space of time only the impressed undamped

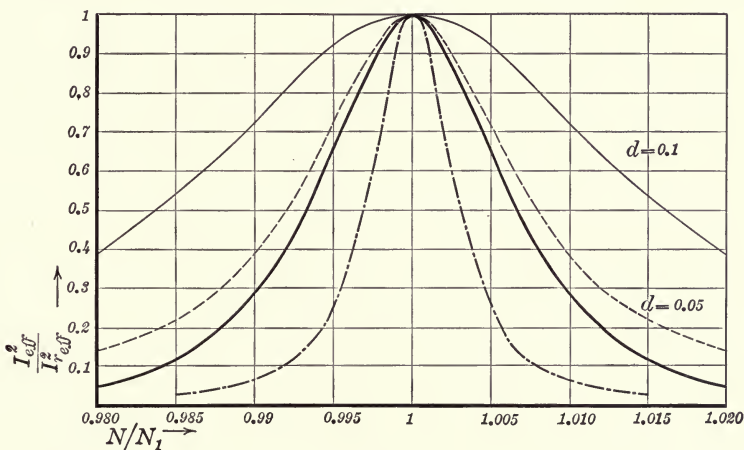

FIG. 386.

oscillations of the transmitter frequency exist in both primary and secondary circuits of the receiver, and they almost solely determine the current effect [Art. 69b]. A simple consideration of this shows that the resonance curve of the receiver is obtained approximately* in the following manner. Plot the resonance curve (the thin full line curve in Fig. 386), which, according to the second foot-note of Art. 74a, corresponds to the

* The exact equation for the resonance curve is:

$$\frac{I_{eff}^2}{I_{r\,eff}^2} = \frac{1 - 4x}{\left(1 + \frac{x^2}{\left(\frac{d_{21}}{2\pi}\right)^2}\right)\left(1 + \frac{x^2}{\left(\frac{d_{22}}{2\pi}\right)^2}\right)}$$

decrement of the receiving antenna with undamped oscillations ($d_1 = 0$), the ordinates being the values of $I_{eff}^2/I_{r\ eff}^2$. Similarly, plot the resonance curve corresponding to the decrement of the secondary circuit of the receiver (dashed line in Fig. 386). Then find the product of the ordinates of these two curves corresponding to the same abscissa. This product is approximately* the value of the ordinate of the desired resonance curve (heavy full line curve in Fig. 386) at the same abscissa.

In Fig. 386, d_{2_1} (receiving antenna) = 0.1, d_{2_2} (secondary circuit of receiver) = 0.05. For $d_{2_2} = 0.02$ the dash-and-dotted line is obtained.*

From the preceding, it follows that by the use of a secondary circuit a much sharper tuning is possible than without a secondary, the difference being the more marked the less damped the secondary circuit is.

d. If the transmitter oscillations are *damped*, the conditions governing a receiver with secondary condenser circuit are quite different. In general two oscillations (of different frequency) are induced in the receiving antenna, one, the impressed oscillation, of the same frequency and decrement as the transmitter oscillation, the other the natural oscillation of the fundamental frequency and decrement of the receiving antenna and hence of the same frequency as the secondary circuit which is tuned to the receiving antenna. Consequently, even if the impressed oscillations have but little effect upon the secondary circuit, the natural oscillations of the receiving antenna will.

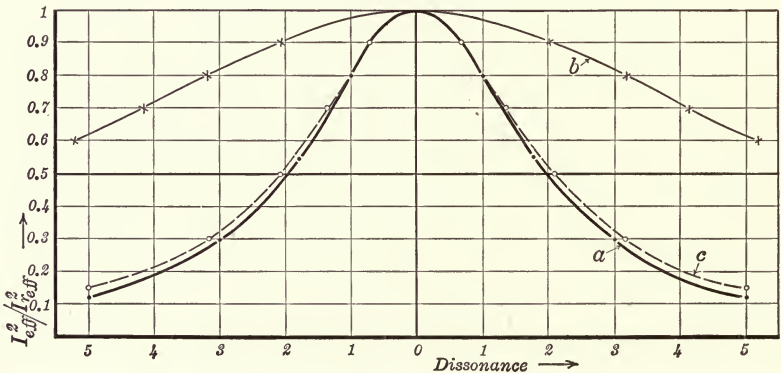

FIG. 387.

The conditions encountered here are relatively complicated, as three damped systems (transmitter oscillations, primary circuit and secondary circuit of receiver) come into question, and moreover as two quite different requirements, viz., maximum resonance and sharpness of tuning on one hand, maximum range on the other hand, counteract each other in this case.

* See foot-note on preceding page.

So far as the *resonance sharpness* is concerned, we may assume that, other things being equal (equal decrements), it increases the looser the coupling between antenna and secondary circuit of the receiver is made. The ideal case, therefore, is that of extremely loose coupling. This has been theoretically investigated by H. RIEGGER;²⁸⁶ some of his results are shown in Figs. 387* and 388A and B.*

The conditions assumed for Fig. 387 are about those existing in the BRAUN transmitter with greatly damped antenna; decrement d_1 of the exciting circuit in the transmitter and hence the decrement of the transmitted oscillations = 0.1 approximately; decrement d_{2_1} of the receiving antenna = 0.3; decrement d_{2_2} of the condenser circuit in the receiver =

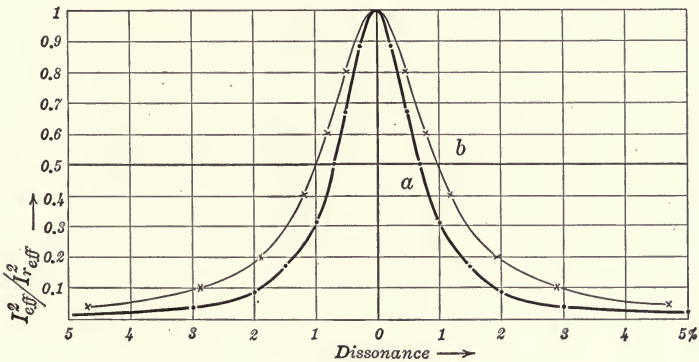

FIG. 388A.

0.03. The resonance curve (a) of the current effect in the condenser circuit shows that the sharpness of resonance which can be attained ($\rho = 50$ approx. [Art. 70c]) is considerably greater than it would be without a secondary condenser circuit, with the antenna acting directly upon the detector. In this latter case the resonance curve would be as shown by curve b, the resonance sharpness would be 15.7, corresponding to $d_1 + d_{2_1} = 0.4$.

The assumptions on which Figs. 388A and 388B are based correspond to a *quenched gap transmitter* and two antennæ with greatly reduced radiation damping: $d_1 = d_{2_1} = 0.03$. In Fig. 388A a relatively large amount of energy supplied to the detector by the condenser circuit ($d_{2_2} = 0.03$) is assumed, while in Fig. 388B, this is assumed to be *very low* ($d_{2_2} = 0.01$). As a means of comparison, the curve b, the resonance curve which would be obtained in the receiver without a secondary condenser circuit and corresponding to $d_1 + d_{2_1} = 0.06$, $\rho = 105$, has been drawn in each figure. Here again it is seen that the secondary condenser circuit considerably

* In these figures curve c is the resonance curve for $d_1 + d_{2_2}$; it almost coincides with curve a.

increases the resonance sharpness ($\rho = 143$ in Fig. 388A, $\rho = 156$ in Fig. 388B).

Accordingly the use of a secondary condenser circuit even in conjunction with *very* slightly damped antennæ, is justified when particularly sharp tuning is desired.²⁸⁷ On the other hand, however, the examples illustrated show that the resonance sharpness attainable without a secondary condenser circuit, suffices for all practical purposes and in fact would suffice even if the decrements of the antennæ were double the decrements assumed for Figs. 388A and B.

The *range* is determined on one hand by the energy supplied to the detector (and hence by the damping, d_{22} , of the secondary condenser cir-

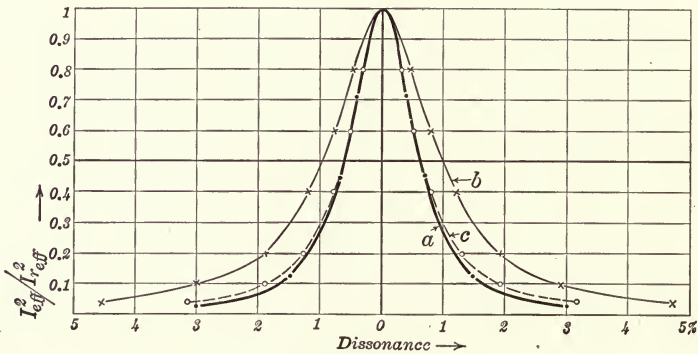

FIG. 388B.

cuit) and on the other hand by the degree of coupling between the receiving antenna and the secondary condenser circuit. The practical problem therefore is: how far may or must we go with both these factors to obtain maximum range without seriously reducing the sharpness of tuning?* Such investigations²⁸⁸ as have been made to date do not suffice for arriving at a general answer to this question. Actual experience in practice has shown that in those cases where there is any condenser circuit in the receiver, *the coupling between condenser circuit and receiving antenna* must in any case be *very loose*, if good tuning is at all required.† It has further been shown that this loose coupling may be adopted without mate-

* A comparison of the two curves marked "a" in Figs. 388A and B respectively, is instructive in this connection. The sharpness of resonance is almost the same in both cases although the energy supplied to the detector in Fig. 388A was assumed about three times as great as that in Fig. 388B.

† Recognition of this requirement originated in the theoretical investigations of M. WIEN²⁸⁹ and in the experiments made by H. BRANDES and L. MANDELSTAM²⁸⁹ at almost the same time. Close coupling is used almost solely for such cases where sharp tuning is of no importance and where it is desired to communicate with various stations of somewhat different wave-length, as for instance in coastal stations communicating with ships at sea or again where it is desired to "listen in" to traffic between other stations [see Art. 184a].

rially sacrificing range, as long as the transmitter oscillations are not too strongly damped. The reason for this is that conditions in the loosely coupled system (secondary or tertiary circuit of the receiver) which acts directly upon the wave indicator, are about of the nature described in Art. 61c—more and more energy accumulates in this system during a series of periods or cycles, so that eventually quite a large amount of energy exists in the system, even if only very little is transferred to it in each period.

This, however, is based on the assumption that all energy consumed in the secondary circuit (Joule heat, eddy currents) without being useful in the wave indicator, is kept as small as possible. Otherwise, the use of a secondary circuit in the receiver may be detrimental to the range without being of much value toward sharpness of tuning.

It may therefore be important to block the path of the oscillations into the circuits of the auxiliary apparatus where a part of their energy would be wasted, by means of *choke coils* [Art. 165b]. If this is done, however, it is essential that the choke coils themselves do not consume any energy;* hence they must have *no iron cores*. With iron cores, they would serve their purpose of keeping the oscillations out of the auxiliary apparatus fully as well if not even better, but hysteresis and eddy current losses in the cores would result.

181. R. A. Fessenden's Method for Maintaining Secrecy of Telegrams.²⁹⁰—The “**secrecy sender**” of Fig. 389 transmits waves uninterruptedly, but when the circuit of the wire loop, K , is closed, their wave-length, λ' , differs from λ , the wave-length to which the receiver is tuned, by an amount given by FESSENDEN as $\frac{1}{4}$ per cent. If the circuit of this wire loop is broken by pressing the key † the transmitter oscillations have the wave-length, λ , for which the receiver is tuned. ‡

At the receiver (“**interference preventer**”) (Fig. 390) the oscillations in the aerial branch off between two paths, AC_1S_1E and AC_2S_2E . The former is tuned to the wave-length λ , the latter being so dimensioned that with the wave-length λ' the amplitude of the oscillations in $\overline{C_2S_2}$ becomes equal to that in $\overline{C_1S_1}$. The coils S'_1 and S'_2 , which are coupled with S_1 and S_2 respectively, are wound so as to oppose or “**buck**” each other, so that with wave-length λ' the electromotive forces induced in S'_1 and S'_2 , practically neutralize each other.

Hence, if the transmitter is operated without depressing the key in loop K (Fig. 389) and wave λ' is sent out, no appreciable oscillations are induced in the circuit $\overline{CS'_2DS'_1}$ of the receiver. But if the key in loop K

* The construction of really good choke coils is not so very simple a matter. Accordingly systems or methods of connection in which no choke coils are needed offer a practical advantage.

† The key is not drawn correctly in Fig. 389.

‡ Compare P. O. PEDERSEN'S method for undamped oscillations [Art. 127c].

is closed and wave λ is sent out, oscillations of very high amplitude are obtained in branch C_1S_1 and of very low amplitude in C_2S_2 ; consequently the electromotive forces induced in S'_1 and S'_2 do not neutralize each other, and the wave indicator, D , responds accordingly.

Undoubtedly this method makes the reception of telegrams very difficult. Unless the receiving station is tuned exactly for the wave-length λ and so sharply that a dissonance of $\frac{1}{4}$ per cent. suffices to make the signals disappear, the signals will be received constantly, whether the key at the transmitter is depressed or not.

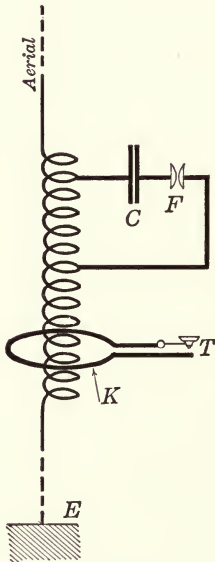

FIG. 389.

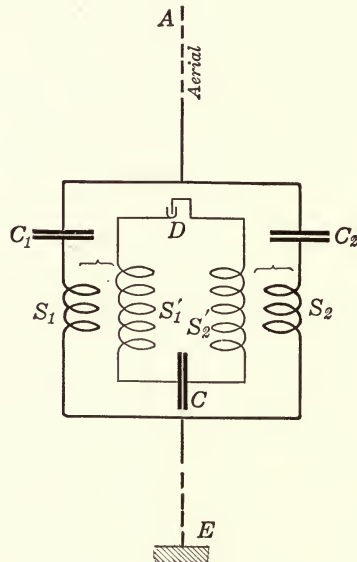

FIG. 390.

The practical tests conducted by the NAT. EL. SIG. Co. with this method were claimed to have given very good results, even in overcoming atmospheric disturbances [Art. 183]; its application, however, will probably remain very limited to a few special cases.

182. Multiplex Telegraphy.—The solution of the problem of constructing a receiver which will respond within certain limits only to a single wave-length, is at the same time a solution of the problem of multiple telegraphy—receiving telegrams from two transmitters simultaneously on one antenna.

a. Fig. 391 illustrates an arrangement of this kind used by MARCONI with considerable success. For the *longer* wave, the primary circuit consists of the aerial, coil S , primary coil I of the transformer and ground. The secondary circuit tuned to this is II . For the *shorter* wave, the primary circuit consists of the aerial, condenser C , primary coil I' of the transformer and ground. The secondary circuit tuned to this is II' . The

conditions are such that the system to the right does not respond to the longer wave, that to the left, not to the shorter.

Any other arrangement for tuned telegraphy can, of course, be similarly used if the tuning is sufficiently sharp.*

b. The simultaneous *transmission* of two telegrams from the same antenna is also feasible. It is simply necessary to couple two different condenser circuits with the aerial, each condenser circuit adjusted so as to be

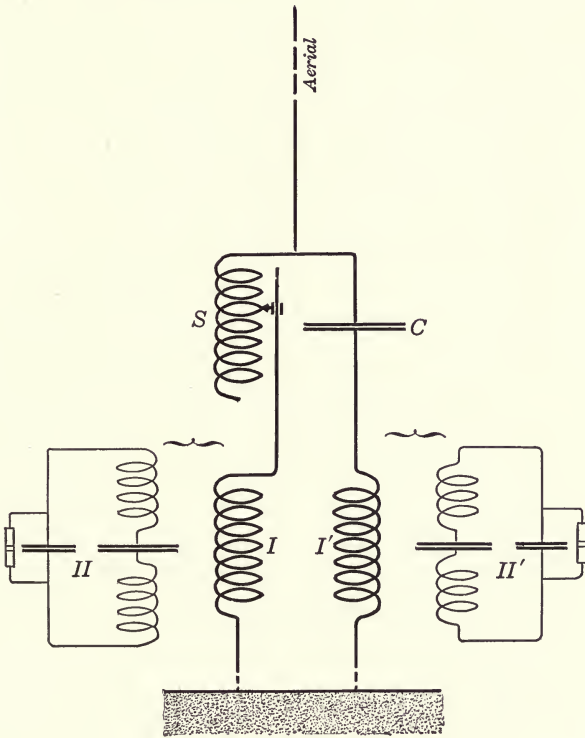

FIG. 391.

in resonance with its own secondary. The connections used by MARCONI are shown in Fig. 392; as in Fig. 391, the portion to the left is for the longer wave, that at the right, for the shorter.

c. In the multiple or duplex telegraph systems just described it is essential that the wave-lengths of the two transmitters whose telegrams are to be received on the same antenna, be different. Duplex reception at the *same wave-length* is possible if both the transmitters are *tone transmitters* and work with *different tones*. Tests of this kind have been made by the TELEFUNKEN CO.,²⁹² two of the sound intensifiers described in

* Thus the TELEFUNKEN CO., *e.g.*, has received telegrams from three different stations simultaneously on a single ship's antenna.²⁹¹

Art. 166*b* were connected to the receiver, each adjusted to the tone of one of the transmitters. Perfect duplex reception in spite of equal wavelengths was possible; as soon as the two tone frequencies differed by 20 per cent.

183. Methods for Overcoming Atmospheric Disturbances.—*a.* The atmospheric disturbances which are particularly frequent during the summer months, and are especially noticeable in the hours from noon or from sunset to sunrise, even in stations where static charging of the antenna is

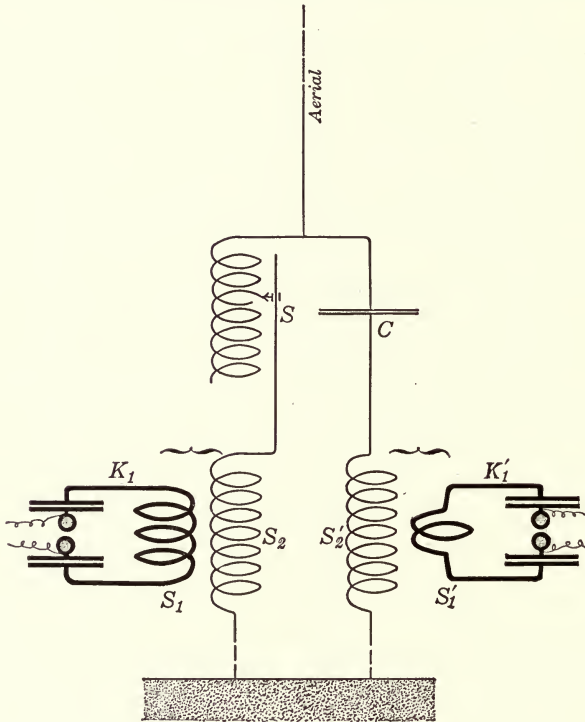

FIG. 392.

out of the question, seem to originate primarily in lightning discharges between two clouds or between a cloud and the earth.²⁹³ This is not contradicted by the frequent disturbances experienced under a clear blue sky; the distance over which clouds can be seen from a point on the earth's surface is extremely short as compared to the distance at which a stroke of lightning can excite a wave detector. Hence an electric storm makes itself felt in a radio-receiving station at tremendous distances.

The early wireless stations, as long as their receivers were arranged for relatively highly damped waves of great amplitude, suffered severely from these atmospheric disturbances, particularly in the tropics. Considerable improvement resulted as soon as the receivers were arranged

for less damped transmitter oscillations of lower amplitude (*i.e.*, low antenna decrement, loose coupling with the secondary condenser circuit or detector circuit).

Even to-day probably the best protection against atmospheric disturbances still is a powerful transmitter permitting the use of very loose coupling and a not too highly sensitive wave indicator in the receiver.

a. MARCONI has devised a number of special arrangements for mitigating the effect of atmospheric disturbances.²⁹⁴

1. The primary circuit of the receiver consists of the aerial and *PCE* (Fig. 393). The natural oscillations of the aerial are so regulated* by means of coil *S* and condenser *C*, that the anti-node of current and node of potential occur at the point *P* [see Art. 31 *et seq.*]. Accordingly if waves of the same length as the natural wave-length of the antenna strike the latter it will oscillate with a potential node at *P*. If now a ground connection *PE*₁ is made at *P*, no appreciable current will flow through it.

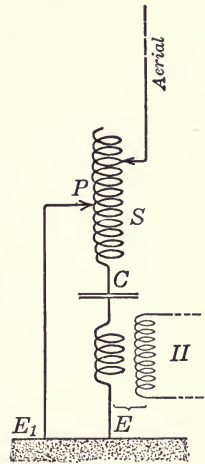

FIG. 393.

But, if any other electromagnetic disturbance occurs, the greatest part of the current induced in the aerial will flow through *PE*₁ to ground as its impedance is lower than that of the path *SCE*. Hence the effect of the disturbance upon the secondary circuit (*II*) is greatly diminished.

Accounts of how successful this arrangement is in practice† have never been published so far as the author is aware.

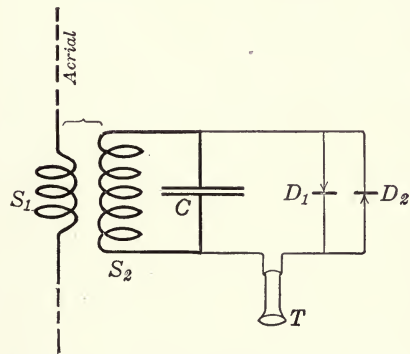

FIG. 394.

2. Another method of the MARCONI Co. is sketched in Fig. 394. *D*₁*D*₂ are two rectifying detectors, of opposite polarity, so that one allows the current to flow through it in one direction, the other in the opposite direction [Art. 162*a*]. For one of them, let us say *D*₁, the size of the auxiliary battery (not shown in Fig. 394) is so chosen that the detector is very sensitive, while for the other, *D*₂,

it is so chosen as to make its sensitiveness very low. Consequently under normal operating conditions only *D*₁ responds and the telephone

* The aerial is of course also tuned to the transmitter.

† It seems probable that this arrangement would also be effective against electromagnetic waves of another length, hence would increase the sharpness of tuning.

receives current in *one* direction only. But if a heavy atmospheric disturbance occurs, both detectors respond, the current flows through in both directions and the telephone is not affected.

b. Those radio-systems which produce a *tone* of more or less purity in the receiving telephone have proven themselves as an excellent safeguard against atmospheric disturbances; for the latter are heard in the telephone as short dissonant crackling and can usually be easily distinguished from the tone signals.

184. Achievements of Tuned Telegraphy.—The advantages* which make tuned telegraphy so decidedly preferable, are best expressed as the following disadvantages of untuned telegraphy:

1. The telegrams can be “picked up” by any and all stations within the range of the transmitter: *no secrecy of telegrams*.

2. Communication between two stations *A* and *B* can be crippled by constantly sending out signals from a station *C* within whose range *A* and *B* are located: *deliberate intentional interference*.

3. If *A* and *A'* on one hand and *B* and *B'* on the other hand are two sets of communicating stations, each of which lies in the range of the other three stations, then *A* and *A'* can not communicate while *B* and *B'* are exchanging messages: *interference between stations*.

Whether or not tuned telegraphy entirely overcomes these obstacles can not be stated for all cases, as the *distance between the stations* in question and their ranges are very important factors. The question can only be: To what extent does tuning overcome these obstacles and are they entirely removed in any specific case?

a. As regards the *maintenance of secrecy of messages*, let us consider the following possible case. A transmitting station, *A*, and a receiving station, *A'*, are arranged for continuous communication with each other. Another station, *C*, is no further from *A* than *A'*. The question “can *C* be prevented from receiving telegrams sent out from *A* by means of the tuning methods previously described?” must be answered by a decided “no.”

If *A* and *A'* are arranged for constant operation their actual (ultimate) range must be much greater than the distance between them [Art. 148] and the wave indicator used must not be too highly sensitive. It follows that it will then be possible to receive the telegrams by means of a *very sensitive* wave indicator in an untuned closed detector circuit [Art. 176].

In general, the ordinary receivers will serve the purpose if the coupling is made closer. Thus, the TELEFUNKEN receiver described in Art. 176 and illustrated in Fig. 236 is specially arranged for this. The coil corresponding to S_2 in Figs. 376 and 377 is movable so that its coupling with S_1 and hence also the coupling between the antenna and the detector circuit can be varied. In order to tune for any transmitter which is sending out

* Aside from the increased range obtained by tuning.

signals the procedure is as follows: Starting with very loose coupling, gradually make the coupling closer until a sound is heard in the telephone. Then adjust the condenser until the sound in the telephone is a maximum. Finally loosen the coupling again very gradually, readjusting the condenser (C in Figs. 376 and 377) if this is necessary, so that maximum loudness is obtained in every case.²⁹⁵

The picking up of messages by stations other than those intended to receive them, is made more difficult according as the amplitude of the oscillations required for the given distance is reduced, by decreasing the damping of the oscillations.

b. Similarly in regard to *intentional interference*,^{295a} assume the disturbing station C to be as near to the communicating stations A_1 and A_2 as these are to each other and that all are normal types of stations of moderate ranges.

First, then, we must take for granted that station C can determine* the wave-length A_1 and A_2 are using and that C tunes its transmitter to give the same wave. C is then in a position to interfere with A_1 and A_2 even if its range is only one-half or one-third of that of A_1 and A_2 .†

Eliminating this case, however, let us assume that C is unable to determine the wave-length used by A_1 and A_2 , so that C 's wave-length differs considerably from that of A_1 and A_2 . Whether or not C can interfere in this case depends simply upon how far it can raise its amplitude. If the receivers at A_1 and A_2 have very loose coupling, C would not be able

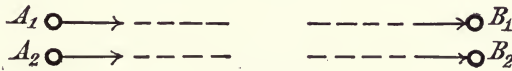

FIG. 395.

to reach a sufficiently great amplitude in its transmitter oscillations to succeed in its purpose.‡ Under these conditions, therefore, tuned receivers provide a much greater protection against intentional interference.

c. In regard to the prevention of *interference between a number of stations* in the same general vicinity, let us consider the following extreme case. Assume two stations A_1 and A_2 very close together at one place, B_1 and B_2 similarly located at another place (Fig. 395). Then we must distinguish clearly between the following two cases:

1. The two stations at one place, say A_1 and A_2 operate as transmitters of equal strength, while those of the other place B_1 and B_2 are both receivers (Fig. 395). Then, by suitable tuning methods, it can un-

* Any wave meter employing a wave indicator is suitable for this purpose. Most wave meters are arranged so as to be suitable for measuring waves coming in from a distance.

† In view of the safety factor with which A_1 and A_2 must operate for constant service.

‡ That is, unless C could come *very near*, to either A_1 or A_2 .

doubtedly be arranged that B_1 receives only A_1 's telegrams and B_2 only those from A_2 , even if the frequencies of A_1 and A_2 differ by only a few per cent. This in itself constitutes a great advantage for tuned telegraphy.

2. If, however, one of the stations must receive while its neighbor is transmitting, the conditions are quite different. Thus let A_1 and B_2 be transmitters, while B_1 and A_2 receive (Fig. 396).

Everything now depends upon the distance of A_1 from A_2 and of B_1 from B_2 . If this distance is only a small part of the wave-length, it will be impossible for A_2 to get the telegrams from B_2 without hearing the signals from its neighbor A_1 whose waves have a tremendous amplitude at so short a distance from the transmitter. But if the stations A_1 and

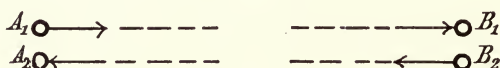

FIG. 396.

A_2 , as well as B_1 and B_2 , are relatively far apart, then of course service between the two pairs, A_1B_1 and B_2A_2 , can be maintained without mutual interference. Just how far apart the neighboring stations must be depends upon the ranges of the stations, the difference between their wave-lengths, the sharpness of tuning of the receivers [Art. 180] and also upon whether the transmitters are single or double wave transmitters, the former being decidedly more advantageous.*

If, even to the present day, frequent complaints of interference between stations are still heard,²⁹⁶ imperfect design of the transmitters (high damping) and receivers is undoubtedly largely responsible for this. It must be remembered that with the great number of shore and ship stations now in operation it would have been impossible to maintain even a passable service using the old methods, whereas with modern systems the service on the whole presents no great difficulties.

d. Stations arranged for *tone transmission* and operating on the *acoustic* or *mechanical resonance principle* [Art. 185] are least affected by interference. For here interference need really be feared only if the disturbing transmitter has the same tone as well as the same wave-length.

185. Methods for Preserving Secrecy of Messages.—The fact that tuning does not in itself suffice to guard the secrecy of messages is a great disadvantage† for many purposes (as in army and navy work).

* The NAT. ELEC. SIG. CO. (FESSENDEN) makes the following guarantee: Given three stations A_1 , A_2 and B_2 of equal range. If the distance A_1-A_2 is 1 per cent. of the distance A_2-B_2 , and the wave-lengths differ by 3 per cent., A_2 will not be disturbed by A_1 . In fact with standard sets a difference of $\frac{1}{4}$ per cent. in wave-lengths is claimed to be sufficient to prevent interference. Reports of tests indicate that this company's apparatus really gives very fine results in this respect.^{296a}

† On the other hand this is a direct advantage for distress calls at sea, where it is important that as many ships as possible hear the call for help.

The interception of messages by stations other than those called, can be prevented to some extent by telegraphing so rapidly that such relays as are customarily used will not respond and only specially trained operators will be able to read the messages in the telephone.* Furthermore the apparatus can be so arranged that the wave-length is easily and rapidly changed and then vary the wave-length in accordance with a prearranged program, perhaps automatically.† This method makes it very difficult for an uncalled listener to tune his receiver to the rapid variations, but it is of no avail against untuned, highly sensitive receivers. Probably all such methods as those described must be regarded as more or less makeshifts, to be used only when absolutely necessary and which are successful only in special cases. The following, however, are important effective methods for providing secrecy.

a. A galvanometer whose natural oscillations are slightly damped (about like the WIEN vibration galvanometer) or a telephone having a diaphragm whose natural oscillations are slightly damped or, again, a telephone combined with a closed spherical resonator^{297a} is used in the receiver. These respond well only if the frequency of the interruptions in the transmitter is the same as their own natural periodicity. This is *mechanical tuning*.‡

The "*sound intensifier*" of the TELEFUNKEN Co. with its oscillating armature [Art. 166b] also belongs to this class of apparatus.

In all such arrangements assuming that the oscillating mechanical system is tuned to the discharge frequency of the transmitter, the curve of the oscillations is like that shown in Fig. 135; *i.e.*, the amplitude of the oscillations rises gradually, first reaching its maximum after several periods, the number of which depends upon the decrement of the oscillating system; both this number of periods and the maximum amplitude increase as the decrement decreases.

Herein lies the explanation of why in all cases of such mechanical tuning the *sensitiveness of the arrangement depends upon the rapidity of operation* (*i.e.*, of telegraphing). For, in order to take full advantage of the sensitiveness, every signal must last long enough for the oscillating system to attain its maximum amplitude. If the telegraphing is done so rapidly that the duration of the individual signals is not sufficient to reach the maximum amplitude, the sensitiveness will be correspondingly reduced.

The decrement remaining constant, the time required by the oscillating system to reach its maximum amplitude increases as the period lengthens, *i.e.*, as the discharge frequency is reduced. For this reason, such devices for mechanical tuning were of little practical use as long as it

* This method was tried at one time by the MARCONI Co. and by the DE FOREST Co.

† This method was adapted by the TELEFUNKEN Co. at one time.

‡ The first proposal of such a method was probably made by A. BLONDEL.

was customary to work with low frequencies, as this greatly limited the permissible rapidity of operation. The adoption of high discharge frequencies in the transmitter has made the use of mechanical resonance in the receiver possible without any great detriment to rapidity of signaling. Nevertheless, even to-day the use of mechanically resonant receivers in conjunction with automatic transmitters operating at *very* high speeds offers great difficulties.

b. Another method has been proposed repeatedly from the earliest days of wireless telegraphy. It is based upon transmitting each signal, say each MORSE dot, not as a single discharge, but as a series of periodic discharges occurring at certain fixed equal intervals. The receiver is then so adjusted that it will respond only to oscillations occurring at these definite intervals.

Probably the only apparatus of this kind which were used in practice were those of ANDRES BULL²⁹⁸ and of HOVLAND.²⁹⁸ They were rather complicated and will not be described in detail here. But it should be pointed out that in practical tests these apparatus gave good results. There can hardly be any question that these apparatus, when properly designed and constructed for reliability in operation, provide an *almost perfect protection not only against the "picking up" of messages by stations not called or intended to receive them, but also against atmospheric disturbances*; on the other hand it is just as true that their complication limits these apparatus to certain special work.

3. RECEIVERS FOR UNDAMPED OSCILLATIONS

186. General.—For *recording* reception, for which thermal and crystal detectors and the EINTHOVEN string galvanometer (photographic method) are generally used, conditions are much the same for undamped as for damped oscillations. *The secondary circuit of the receiver is made as slightly damped as possible, is loosely coupled to the antenna* [see Art. 175] and may react in any way upon the detector.

But for *telephone reception* a decided difference is encountered between damped and undamped oscillations; the arrangements for receiving damped oscillations, described in Art. 165, can not be used without modification for undamped oscillations. For in telegraphing a dash of the MORSE code, the excitation of the wave indicator would displace the telephone diaphragm from its normal position at the beginning of the dash, causing a click to be heard and nothing more, as the telephone diaphragm remains displaced in a fixed position just as long as the waves from the transmitter keep coming in and the wave indicator remains excited. Hence dashes and dots could not be distinguished as both would be heard simply as clicks.

This difficulty can be overcome by sending the oscillations out in a

series of "wave trains" obtained by means of a kind of interrupter in the transmitter. It is much simpler, however, to provide the *interrupter at the receiving end*, using it to alternately make and break the connection of the wave indicator to the oscillating circuit. Then the telephone diaphragm is displaced at each "make" and returns to its normal zero position at each "break." That is, the motion of the diaphragm has the same frequency as the interrupter. Consequently as long as waves strike the receiver, the tone of the interrupter is heard in the telephone, being audible for relatively long and short periods as MORSE dashes and dots are transmitted.

In telegraphing with *damped* oscillations, an interrupter would likewise be needed if the discharge frequency were above that (several thousand per second) of easily audible sounds. This condition is easily obtained with quenched spark gaps and D.C. operation, but to the Author's knowledge, has never been used in *radio-telegraph* practice, being restricted to radio-telephony.

187. Methods Employing the Ordinary Detector.—*a.* Fig. 397 illustrates diagrammatically one of the arrangements used for the reception of undamped oscillations (V. POULSEN, C. LORENZ²⁹⁹).

The condenser circuit drawn in heavy lines is the secondary of the receiver; it is as slightly damped as possible and very loosely coupled to the antenna. The interrupter, *U*, which operates on the principle of the electric bell or buzzer, alternately connects and disconnects the detector and its auxiliaries to and from the secondary circuit several hundred times per second. This arrangement can of course be varied in a great number of ways.

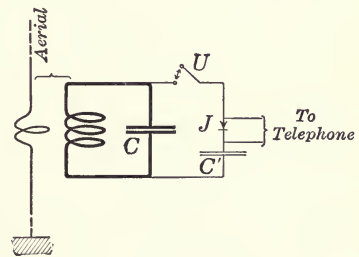

FIG. 397.

b. The interrupter used in this method is something more than a necessary evil. It has a certain decided advantage.

It has been shown that it is of the greatest importance, both for the sharpness of tuning [Art. 180c] as well as for range [Art. 67b] to have *as little damping as possible* in the secondary.

As long as the detector is connected to the secondary, the energy (as long as it remains in the vicinity of the critical value [Art. 162b] of the detector) which is not converted or only partly converted into direct-current energy, is consumed in the detector. In the auxiliary apparatus and their connecting leads energy losses can hardly be entirely eliminated, in spite of the insertion of choke coils.

But when using an interrupter, no such loss can occur in the wave indicator or in the auxiliary apparatus whenever these are disconnected. The amplitude of the oscillations in the secondary circuit and hence the

energy stored in it, rise to a very high value. Then when the interrupter connects the wave indicator into the circuit, it is acted upon by an oscillation of very great amplitude and almost all the energy accumulated in the secondary circuit is used for exciting the wave indicator.

POULSEN seems to have succeeded in reducing the decrement of the secondary circuit to 0.003 in this way.³⁰⁰ This could not be attained if a wave indicator with its accessories were continuously in circuit.

e. A further advantage of the interrupter is the possibility of producing a musical tone in the telephone by suitable connections and so obtain to some extent the same advantages secured by means of a tone transmitter with damped oscillations.

188. The Ticker.³⁰¹—a. The so-called "ticker" method devised by POULSEN, in which none of the wave indicators described in Chap. X is used, is shown in Fig. 398. Here U is the interrupter and the secondary circuit proper is drawn in heavy black lines.

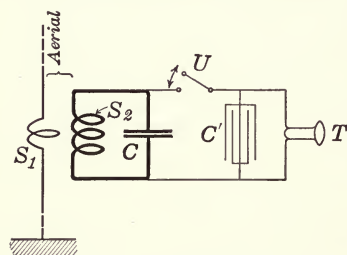

FIG. 398.

C' is a very large condenser of several tenths of a microfarad capacity, while C has only a few thousandths of a microfarad capacity. Many modifications of this arrangement have been devised.*

b. The basic idea in POULSEN'S arrangements (Fig. 398) is as follows: As long as condenser C' is disconnected from the oscillating circuit CS_2 , the latter accumulates a relatively large amount of energy. Then, when the ticker connects the large condenser C' in parallel to the small condenser, C , C' takes the major part of the current and of the stored energy, so that it obtains a relatively high charge, which upon discharging through the telephone, T , causes a click to be heard in the latter. Even though the procedure may be somewhat more complicated in its details than here outlined, the essential features of what occurs are as just described.

c. The sensitiveness of this arrangement for telephone reception seems to be greater than for methods using any of the best wave detectors described in Chap. X. The latter all have a low efficiency, *i.e.*, the direct-current energy delivered by them is only a small fraction of the high frequency energy supplied to them [Art. 162b]. Too great a loss is involved in the double transformation, first from electrical energy to

* The following arrangement (TELEFUNKEN Co.³⁰²) is very interesting. The interrupter U in Fig. 398 is replaced by a rectifying detector allowing current to flow in one direction only. The interrupter is inserted between C' and the telephone T . The unidirectional current flowing through the detector charges condenser C' , which can not discharge through S_2 on account of the detector. As the interrupter alternately connects and disconnects the telephone T to and from condenser C' , the latter discharges through the telephone when they are connected and is recharged when T is disconnected.

heat and then back from heat to electrical energy. In the ticker, on the other hand, there is practically no real energy transformation, for the charge momentarily stored in condenser C' (Fig. 398) is directly discharged through the telephone. Occasional irregularities in the interrupter, causing the "make" and "break" to occur at the wrong instant, will have but little effect in reducing the efficiency if the condenser circuit CS_2 (Fig. 398) is only slightly damped.

With good construction of the interrupter, its operation is said to be very regular and reliable. On the other hand, it does not seem possible to obtain a pure tone in the telephone and so secure the same freedom from atmospheric disturbances with the ticker as is obtainable with the tone transmitter [Art. 183*b*]. This constitutes a serious disadvantage, particularly in the tropics.

189. Construction of Interrupter for Ticker Method.—The construction of a *good* practical interrupter for use in the ticker systems, is not so simple as might at first sight appear.

a. The arrangement, which is probably in widest use at present, is shown diagrammatically in Fig. 399: *b* is an electromagnet facing the small armature *c*, which is vibrated, just as in an electric bell or buzzer, by a battery connected to the winding of the magnet. The spring *d*, on which the armature is mounted, is fastened to a plate having a slight spring to it. Resting on this plate is a small piece of metal, *e*, to which a fine gold wire, *f*, is attached. This gold wire together with the small adjustable wire brush, *g*, constitutes the ticker contact.

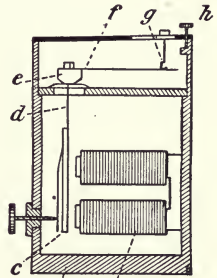

FIG. 399.

The sensitiveness of this arrangement can be increased by using a telephone diaphragm of low damping to whose natural oscillation the ticker is tuned [see Art. 185*a*].

b. L. W. AUSTIN³⁰³ has described a *rotary interrupter* which is said to be particularly well suited for use in conjunction with the ticker. It consists of a highly polished copper or nickel disc which is kept in rotation, while a fine copper wire brushes against the disc under very light pressure.

190. Special Arrangements for Undamped Oscillations.—*a.* The *heterodyne*, receiver of R. A. FESSENDEN.³⁰⁴ The principle of this receiver is well illustrated by the following description of one form in which it has been constructed. The telephone, instead of having the usual permanent magnet, has a core of fine iron wires within a winding and instead of an iron diaphragm, has one of mica carrying a coil of fine wire.

The oscillations induced in the receiver by the incoming waves are led through the coil in the diaphragm. A high frequency current, whose

frequency, N' , differs somewhat from that, N , of the incoming oscillations is sent through the winding of the electromagnet.

The force* exerted upon the diaphragm coil by the field of the iron wire core varies periodically. Consequently, the telephone diaphragm oscillates at a frequency which = $N - N'$, as will be evident from a simple consideration of the facts. Hence, if N and N' are so chosen that the frequency equal to their difference lies within the range of audible tones, this tone, $N - N'$, will be heard in the telephone.

b. R. GOLDSCHMIDT'S³⁰⁵ method. The principle upon which this method is based is easily understood from a consideration of Art. 122. The oscillations, of frequency N , which are induced in the receiver by the waves from the transmitter, are led through a fixed coil (S in Fig. 261). In the revolving field of this coil there is a movable coil, R , which rotates at N' revolutions per second. Then there will be induced in this movable coil a current of frequency $N - N'$, which under proper conditions can be heard in a telephone, even though N and N' individually lie far outside the range of audible tones.

In practice, of course, the fixed and movable coils, S and R , are replaced by the stator and rotor respectively of a high frequency generator. By adjusting the speed of the machine, the rotor currents are made audible in a connected telephone.

191. Practical Achievements.—*a.* The question, to what extent tuning the receiver can prevent disturbance from other stations and secure privacy of messages when working with damped oscillations was discussed in Art. 184. The question now arises whether the use of *undamped* oscillations will materially alter these conditions.

In regard to securing *secrecy of messages* it is evident from Art. 184*a* alone, that undamped oscillations have a great advantage over damped oscillations; for the lower the amplitude required to attain a given range, the more difficult it becomes to "pick up" a telegram.

For this same reason it would seem that undamped oscillations should also provide a greater protection against *intentional disturbance* by other stations. Actually, however, this advantage is not very great when compared with well-designed stations operating with damped oscillations.

b. In regard to interference between two stations (and the same applies to the use of undamped oscillations in multiplex telegraphing), we would expect that undamped oscillations, in view of the very loose coupling in the receiver and the very low damping of the secondary circuit, would offer very decided advantages and secure particularly sharp tuning. And this would undoubtedly be the case if the same conditions

* Or rather, to be more exact, its mean value during one period. Of course, this force varies continuously during each period, but these rapid variations do not come into consideration for the motion of the diaphragm.

obtained in the transmitter as with damped oscillations. But in practice the frequency of the undamped oscillations is never quite constant, whether they are produced by a high frequency alternator or by an arc generator. As to just how much the frequency has been found to fluctuate in the high frequency alternators which have been built to date, nothing has been published so far as the author knows. With the arc method, it seems that a sharpness of tuning fully as good as, but not better than the best obtainable with damped oscillations can be secured;* and there is no need for any still greater sharpness.

* P. O. PEDERSEN¹⁸⁶ states that in the method of transmitting used by him [Art. 127c] a dissonance of $\frac{1}{2}$ per cent. in the transmitted wave sufficed to prevent reception. This would indicate a very great sharpness of tuning.

CHAPTER XIII

DIRECTIVE TELEGRAPHY

192. Characteristic of the Distance Effect.—The object in view in “directive telegraphy” is to so confine the radiation of waves from the transmitter to a narrow or rather an acute angle, that only receivers located within this angle will be in the path of the waves. Actual accomplishment, so far, consists in transmitters whose waves radiating in different directions have widely differing amplitudes.

a. The following method is convenient for obtaining a picture or “curve” of the power of any given transmitter to direct its waves. The *amplitude* of the waves is measured from point to point on a circle (of suitable radius) whose center is at the transmitter and the values so

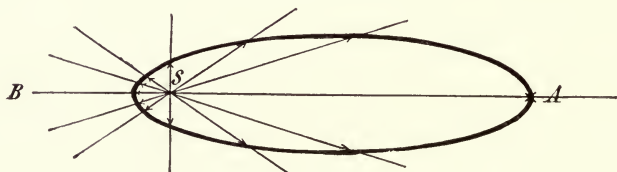

FIG. 400.

obtained are plotted as vectors in the directions or angles corresponding to each amplitude (Fig. 400). The curve obtained by joining the ends of the vectors is the “characteristic of the distance effect” and gives a simple picture of the usefulness of the particular transmitter for directive signaling.

It is self-evident that the characteristic of all symmetrical, vertical transmitters is a circle. If the characteristic is of the form shown in Fig. 401, the obvious conclusion is that the transmitter in question emanates waves in all directions, but its effect in the direction *SB* is considerably less than in all other directions. The case illustrated in Fig. 402 is much more desirable for directive transmission; no waves are sent out in the direction *SB*, practically all being concentrated in the direction *SA*, so that in directions diverging even only very slightly from *SA*, the effect is very much less. A transmitter having this characteristic would be a practical solution of the problem of directive telegraphy; its effect would be confined to an extremely acute angle.

b. For detectors which react upon the *current effect*, reception depends, not upon the amplitude of the waves, but upon the square of the

amplitude. Hence, to obtain a picture of the distance effect of a transmitter with respect to a receiver of this type the *squares* of the wave amplitudes in the different directions must be plotted as vectors in the diagram. The characteristic of amplitude squares is distinguished from that of the amplitudes in that it is much less like a circle in form* and, therefore, is much better suited to the purpose in view. It follows that detectors which react upon the current effect, as, *e.g.*, thermal detectors,

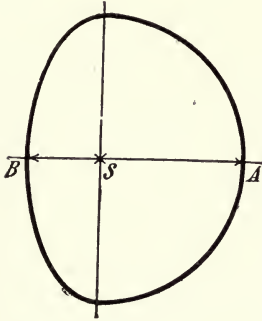

FIG. 401.

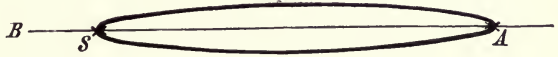

FIG. 402.

are much better adapted for directive signaling than those whose action depends upon the amplitude (first power) of the oscillations [see Art. 163a].

In what follows, the simple characteristics (first powers of the amplitudes) are plotted throughout, as these (but not the squares of the amplitudes) also serve as a direct measure of the range of the transmitter in the various directions (see *c*).

c. The characteristic of a transmitter generally depends upon the distance† at which the amplitudes are measured. Strictly speaking, therefore, we can only refer to the characteristic of a transmitter *at a given distance*.

However, as the distance becomes very great in comparison with the wave-length employed, then, in general, further increases in the distance will have little or no effect upon the shape of the characteristic. Hence, we are justified in speaking of “the” long distance characteristic of a transmitter. *This same characteristic* can also be obtained by plotting the ranges of the transmitter (for a given receiver) over a highly conductive ground‡ as vectors in the various directions.

But for distances which are not large compared to the wave-length, or

* Thus, if the ratio of the lengths of two vectors in the amplitude characteristic is 1:2, then it will be 1:4 for the corresponding vectors in the characteristic of the squares.

† In this and what follows the effect of the distribution of land and water and other local influences upon the characteristic is not taken into account; the ground is assumed to be homogeneous in all directions.

‡ Otherwise absorption would complicate the conditions.

perhaps even shorter, the shape of the characteristic is largely dependent upon the distance. Consequently a characteristic determined by measurements relatively close to the transmitter gives no definite indication of the long distance characteristic and can not serve as a measure of the *'practical usefulness of the transmitter'*. A transmitter whose characteristic at a short distance appears very advantageous for directive signaling, may nevertheless have a long distance characteristic which is almost a circle.

1. THE FIRST ATTEMPTS

193. Use of Reflectors.—To attain the almost ideal case represented by Fig. 402, an adaptation of HERTZ's parabolic mirror method as employed in his well-known experiments, readily suggests itself. In fact it has often been proposed to use such reflectors of sheet metal or wires to send the waves out in a single direction. MARCONI also conducted some early experiments with reflectors.

This was reasonable enough as long as it was customary to work with very short waves. In modern practice, however, the wave-lengths employed range from 300 to 6000 m. or more. A reflector, to have the desired result, as obtained in optics or in HERTZ's experiments, would have to have dimensions commensurate with the wave-length. This requirement is sufficient to eliminate the practical use of reflectors for the wave-lengths in question.

194. Attempts at Screening, J. ZENNECK.—A characteristic of the kind shown in Fig. 401, *i.e.*, with very little radiation in one direction (*SB* in Fig. 401), was obtained by the author as early as 1900 in the following manner.

At a station, *A* (Kugelbake, near Cuxhaven), two vertical wires, d_1d_2 (Fig. 403), about 30 m. long were suspended about 6 m. apart.

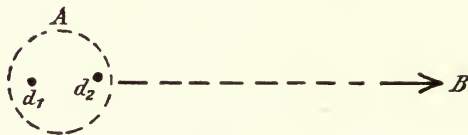

FIG. 403.

The receiving station, *B* (Altenbruch Lighthouse) was situated about 9 km. from *A* and nearly, though not quite, in line with d_1d_2 . With only one aerial wire in use the messages sent out could be well understood at the receiving station, but at twice this distance reception was no longer possible, so that we were working with a safety factor of a bit less than 2. The following tests were then made:

1. d_1 used as transmitting aerial, d_2 not grounded; the signals were clearly audible at *B*;
2. d_1 again transmitting, d_2 grounded; no reception at *B*;

3. d_2 transmitting, d_1 grounded; signals clearly received at B .

From 1 and 2 it was concluded that it is possible to greatly reduce the range in a given direction by means of a grounded wire parallel to the transmitting aerial; from 3, that this does not materially affect the range in the opposite direction.

The results of the experiment left no doubt that, *e.g.*, a station A (Fig. 404) can send telegrams to another station B , while a third station

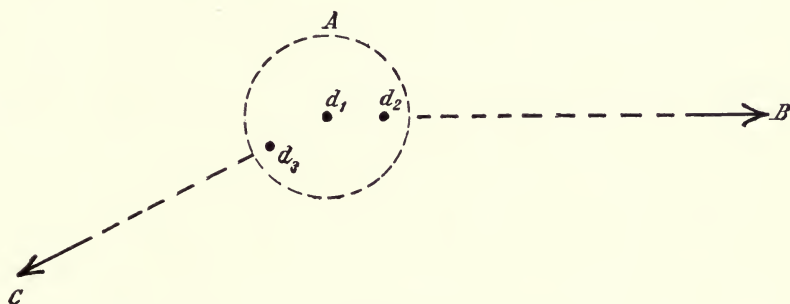

FIG. 404.

C , at the same distance as B , does not receive these messages, if wire d_1 at A is used as the transmitter, d_3 is grounded and d_2 is insulated from the ground. Insulating d_3 and grounding d_2 reverses the conditions so that C , and not B , receives.

These tests were taken up by the TELEFUNKEN Co. at a later date and the results verified. It was here shown that an essential factor consists in having the screening aerial tuned to the transmitter frequency, which condition was really fulfilled in the tests when the screening aerial was grounded. These tests were not carried out far enough to form definite conclusions of just what can be accomplished in this direction.*

2. METHODS EMPLOYING SEVERAL ANTENNÆ

195. The Field of Several Antennæ.—General Consideration.—If two vertical antennæ, oscillating at the same wave-length, are a given distance apart, then the amplitude of the resultant wave produced by the two antennæ is never uniform in all directions, whether or not the currents in the two antennæ are in phase. At any distant point P (Fig. 405), the two waves which are there superimposed have traveled different distances and in view of this difference (AD , Fig. 405) they are *not in phase* with each other [Art. 206]. This phase difference φ —assuming the currents in the two antennæ to be in phase—is proportional

* The explanation of the action of this arrangement lies partly at least in the fact that the transmitter induces oscillations in the screening aerial whose phase is displaced from that of the transmitter oscillations.

to the ratio of the difference in the distance traveled to the wave-length, as given by

$$\varphi = 2\pi \frac{AD}{\lambda} = \frac{2\pi d}{\lambda} \cos \vartheta$$

where the angle ϑ is a measure of the direction in which the point P lies and d is the distance between the two antennæ.

But this phase difference, φ , and hence also the angle ϑ , affect the amplitude of the resultant field at P , which is obtained from the individual amplitudes by means of the familiar vector diagram. Thus in Fig. 406, the length of vector OB is proportional to the amplitude of the field at P due to antenna B , while vector OA represents the field due to antenna A ; angle BOA is equal to the difference in phase between the two fields,* *i.e.*, in this case, it is equal to the phase difference, Ψ , of the

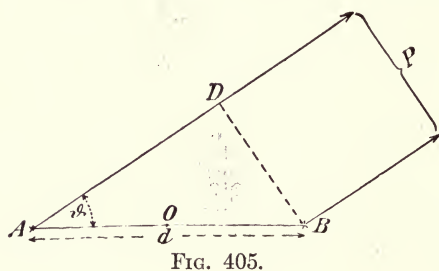

FIG. 405.

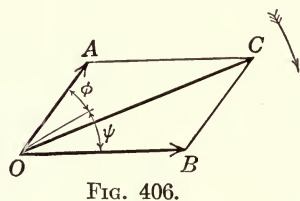

FIG. 406.

two currents in the antennæ A and B , plus the phase difference in the waves φ caused by their difference in travel. The diagonal OC of the parallelogram $OACB$ represents the amplitude and phase of the resultant field at P .

From this construction it is evident that the length of OC and, hence, the amplitude of the resultant field at point P depend upon the angle φ and therefore upon the direction of P with respect to AB .†

196. The Field of Several Antennæ.—Special Cases.³⁰⁶—The following special cases, involving two antennæ *alike in all respects*, are of particular interest:

1. The currents in the two antennæ are equal in phase ($\Psi = 0^\circ$) and amplitude.
2. The currents are of opposite phase ($\Psi = 180^\circ$), the amplitudes equal.

* The feathered arrow in Fig. 406 indicates the direction of “lead,” *i.e.*, the current in antenna A “lags” behind that in B by the angle Ψ .

† If the amplitudes of the fields of both antenna are equal to each other and are E_0 , then the amplitude E_{r_0} of the resultant field is given by

$$E_{r_0} = 2E_0 \cos \frac{\varphi + \Psi}{2} = 2E_0 \cos \left[\frac{\pi d}{\lambda} \cos \vartheta + \frac{\Psi}{2} \right]$$

which also determines the characteristic of the distance effect.³⁰⁷

3. The currents have equal amplitudes as before, but their phase displacement, Ψ , is so great, that their resultant effect is neutralized either in direction OA or direction OB (Fig. 405) in the plane of the antennæ. For this purpose the value of Ψ must be either $\pi - \frac{2\pi d}{\lambda}$ or $\pi + \frac{2\pi d}{\lambda}$ (Fig. 405).

a. If the currents in the two antennæ are equal in both amplitude and phase ($\Psi = 0$), then it follows directly from Art. 25c that in a direction perpendicular to the plane of the antennæ ($\vartheta = 90^\circ$ or 270°) the resultant amplitude is simply the sum of the individual amplitudes of the two fields, *i.e.*, the amplitude of the resultant field $E_{r_0} = 2E_0$, if E_0 is the amplitude of the field of each antenna. In the plane of the antennæ, the resultant amplitude is not the algebraic sum, as a phase difference, $\varphi = \frac{2\pi d}{\lambda}$, exists here; accordingly the resultant amplitude is always less than $2E_0$, becoming smaller as the phase difference φ approaches 180° (π) or, in other words, as the distance d between the antennæ approaches $\frac{\lambda}{2}$.*

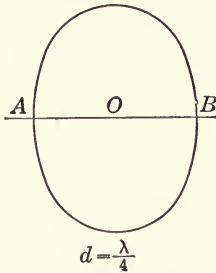

FIG. 407.

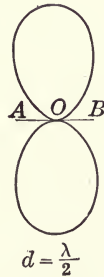

FIG. 408.

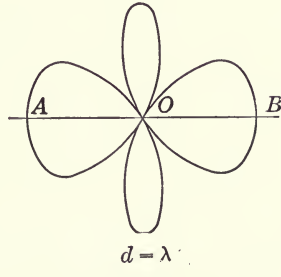

FIG. 409.

In Figs. 407 to 409 the distance effect characteristics of such a pair of antennæ are drawn for various values of d , *viz.*, $d = \frac{\lambda}{4}$ in Fig. 407, $d = \frac{\lambda}{2}$ in Fig. 408 and $d = \lambda$ in Fig. 409. Obviously this arrangement is suitable for directive signaling only when the distance between the antennæ is about one-half the wave-length.

b. If the currents in the two antennæ are equal in amplitude, but have a phase difference, Ψ of 180° , the two fields neutralize each other in the direction perpendicular to the plane of the antennæ. Furthermore, the

* In that case the amplitude of the resultant field and the characteristic of the distance effect are given by

$$E_{r_0} = 2E_0 \cos \frac{\varphi}{2} = 2E_0 \cos \left(\frac{\pi d}{\lambda} \cos \vartheta \right)$$

distance effect characteristic* depends largely upon the distance between the antennæ, d , as compared to the wave-length. If the ratio $\frac{d}{\lambda}$ is very small, the characteristic practically consists of two circles† (Fig. 410). Even if $d = \frac{\lambda}{2}$, the characteristic is not much different from this form (Fig. 411). But if the distance between the antennæ is further increased, the characteristic becomes less favorable for directive telegraphy; thus Fig. 412 represents the results obtained if $d = \frac{3}{4}\lambda$.

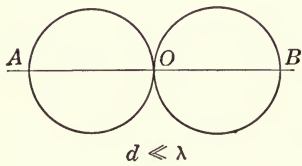

FIG. 410.

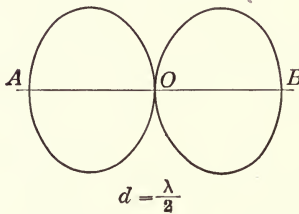

FIG. 411.

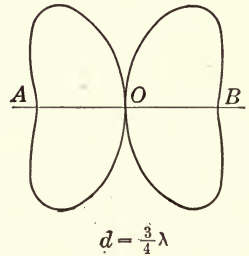

FIG. 412.

It should be noted that with the antennæ *very close together* ($\frac{d}{\lambda}$ very small) the characteristic has a relatively *advantageous* form. One thing however must not be forgotten. The amplitude of the electric field in the plane of the antennæ, which in fact is the *maximum* amplitude in this case (and for values of d up to $\frac{\lambda}{2}$), is $2E_0 \sin \frac{\pi d}{\lambda}$ ‡. Accordingly it and, therefore, the maximum range and practical value of the arrangement are greatly reduced as d is decreased.

c. In the third special case under consideration, where the phase difference Ψ , between the two antenna currents is so chosen that their resultant effect is zero either in the direction OA or in the direction OB (Fig. 405) in the plane of the antennæ ($\Psi = \pi \pm \frac{2\pi d}{\lambda}$), the characteristics obtained have a distinct difference from those obtained in the other two cases. The latter always consisted of two symmetrical halves, so that

* The characteristic is determined by the equation

$$E_{r_0} = 2E_0 \sin \frac{\varphi}{2} = 2E_0 \sin \left(\frac{\pi d}{\lambda} \cos \vartheta \right)$$

† This is evident from the fact that for this case we can write: $E_{r_0} = 2E_0 \cdot \frac{\varphi}{2}$
 approx. = $2E_0 \cdot \frac{\pi d}{\lambda} \cos \vartheta$ approx.

‡ This amplitude is

$$\begin{aligned} 2E_0 \times 1 & \text{ for } d = \frac{1}{2} \lambda \\ 2E_0 \times 0.71 & \text{ for } d = \frac{1}{4} \lambda \\ 2E_0 \times 0.31 & \text{ for } d = \frac{1}{10} \lambda \end{aligned}$$

the same range is obtained in any two directions 180° apart; the arrangement is said to be “bilateral.” Transmitters of the third class however are “unilateral,” *i.e.*, the ranges in any two directions 180° apart are different.

In Figs. 413, 414 and 415 the distance effect characteristics* are given for the following cases: $d \leq \frac{1}{12}\lambda$ (Fig. 413); $d = \frac{1}{4}\lambda$ (Fig. 414); $d = \frac{1}{8}\lambda$ (dotted curve, Fig. 415); $d = \frac{3}{8}\lambda$ (full line curve, Fig. 415).

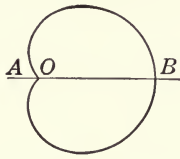

$d \leq \frac{\lambda}{12}$
FIG. 413.

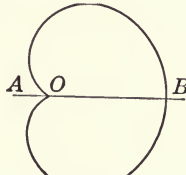

$d = \frac{\lambda}{4}$
FIG. 414.

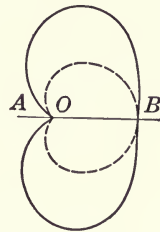

FIG. 415.

Just as in case *b* the characteristic becomes unfavorable for directive signaling in this case also, as soon as the distance between the antenna is made more than one-fourth of the wave-length, whereas very small distances between the antennæ are very advantageous. But, again as in case *b*, the maximum range is reduced at the same time as the ratio $\frac{d}{\lambda}$ is decreased.

197. Double Antennæ, One-half Wave-length Apart (S. G. BROWN, A. BLONDEL, J. STONE STONE³⁰⁸).—*a.* The case discussed in Art. 196*b*, which is particularly advantageous both with respect to directive power and range—two similar antennæ placed a half wave-length apart, with their currents of equal amplitude but opposite phase—has been frequently proposed since 1899, by various experimenters. To produce the oscillations the antennæ are joined at their bases, *A* and *B*, by a conducting circuit which is suitably coupled [Art. 198*a*] to a condenser circuit. This arrangement is not entirely identical with the case discussed in Art. 196*b*, for to the effect of the vertical antennæ *AC* and *BD* is added that of the horizontal portion *AB*, which under certain conditions [Arts. 203*b* and 206] may be quite considerable.

It is almost self-evident that a pair of antennæ of the kind just described will serve for *directive reception*,† *i.e.*, will respond with varying

* If the phase difference is so chosen that the fields of the two antennæ neutralize each other in the direction *OA* or *OB* (Fig. 405), then we have

$$E_{r_0} = 2E_0 \sin \left[\frac{\pi d}{\lambda} (\cos \vartheta - 1) \right] \text{ or } E_{r_0} = 2E_0 \sin \left[\frac{\pi d}{\lambda} (\cos \vartheta + 1) \right]$$

For small values of $\frac{d}{\lambda}$ these equations may be simplified into $E_{r_0} = 2E_0 \cdot \frac{\pi d}{\lambda} (\cos \vartheta \mp 1)$.

† For this purpose a detector circuit is coupled to the antenna pair at the anti-node of current.

intensity as the direction of the approaching waves varies. Thus waves whose direction is perpendicular to the plane of the antennæ, induce potentials of equal phase and amplitude in both antennæ, so that these would neutralize each other and produce a zero effect in the system shown in Fig. 416. But waves approaching in the plane of the antennæ—if their wave-length is $2AB$ (Fig. 416)—induce potentials of opposite phase

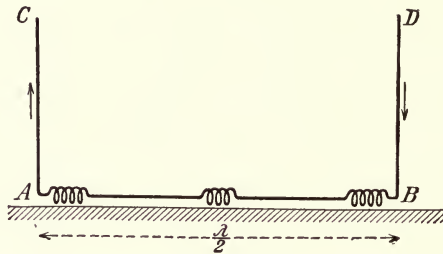

FIG. 416.

in the two antennæ, so that their effect upon the oscillatory system is additive.*

b. A somewhat different form of the double antenna (Fig. 417) has been proposed by A. BLONDEL.³⁰⁸ When used for transmission, the same condenser circuit is coupled with the coils S and S' in such manner that the currents in the two antennæ will be of opposite direction. Then, so

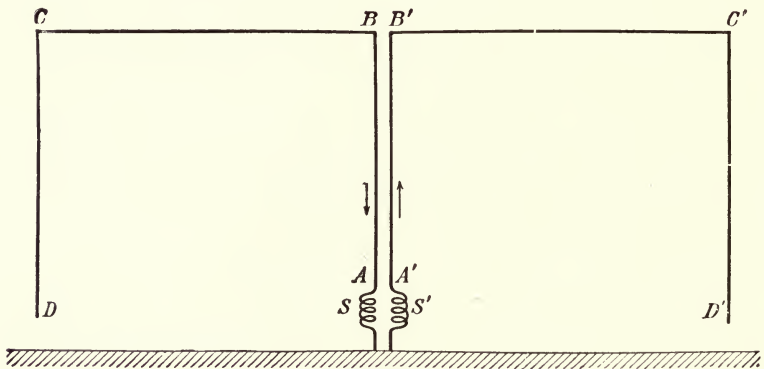

FIG. 417.

far as distance effect is concerned, the currents in the vertical parts AB and $A'B'$ entirely neutralize each other, and all that remains is the effect of the currents (of opposite direction) in parts CD and $C'D'$ (whose dis-

* The distance effect characteristic, at least for the vertical portions of this double receiving antenna, would be the same as for the antenna pair when used for *transmitting*, as will be readily understood by reversing the conditions in the discussion of Art. 196.

tance apart is made about equal to a half wave-length) and of the currents in the horizontal portions BC and $B'C'$.

198. The Methods of E. Bellini and A. Tosi.³⁰⁹—*a.* BELLINI and TOSI have also adapted the case described in Art. 196*b*, using two antennæ with currents of equal amplitude but opposite phase, but the distance between their antennæ is sometimes only slightly, sometimes much less than half the wave-length. Instead of being vertical, however, the antennæ are slightly *inclined* (Fig. 418). This arrangement has the advantage of being more easily suspended from a *single* mast. When located over ground of very high conductivity (sea water) the action of

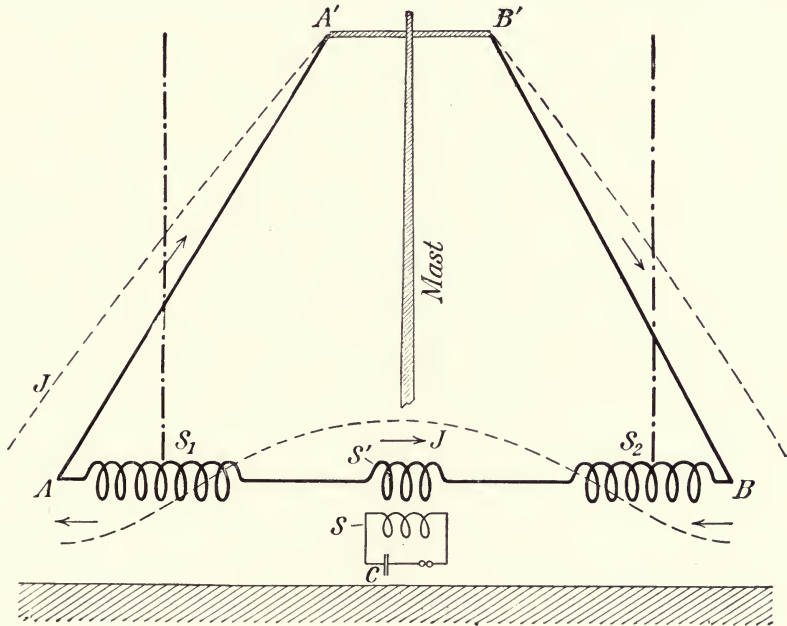

FIG. 418.

such a pair of inclined antennæ is not much different from that of a vertical pair of the same height, but somewhat closer together (as represented by the dash-and-dotted lines in Fig. 418). But over ground of relatively low conductivity, the distance effect characteristic is apt to be considerably different from that obtained with two vertical antennæ [see Art. 205]. In this last case the horizontal portion AB (Fig. 418) is likely to have a material effect.

In order to obtain oscillations of opposite phase in the two inclined antennæ, BELLINI and TOSI make use of the *second upper harmonic**—

* Corresponding to the second upper harmonic shown in Fig. 34. The fundamental oscillation, in which $A'ABB'$ is equivalent to one-half the wave-length, can also be used for this purpose.

third harmonic—of the entire system [Art. 22] (Fig. 418). For any given distance between the inclined antennæ, the upper harmonic is obtained, say, by inserting self-induction (or perhaps condensers also) of suitable dimensions. The oscillations are then induced by means of a condenser circuit, *CS*, Fig. 418, tuned to the frequency of the desired harmonic.

When this arrangement is to be used for *reception*, the condenser circuit is replaced by a detector circuit. The system then reacts with the greatest intensity upon waves whose direction lies in the plane of the antennæ.

b. With the arrangement of Fig. 418, the direction of maximum wave amplitude lies in the plane of the antennæ. If this direction is to be

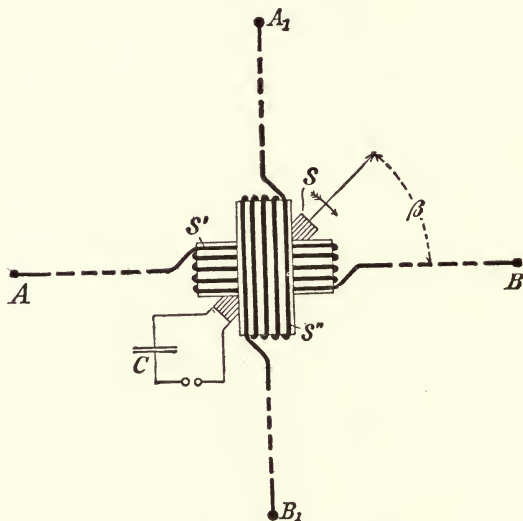

FIG. 419.

varied at will it is necessary to turn the entire system. This would be impracticable on shipboard and particularly on fixed land stations. In view of this, BELLINI and TOSI have introduced another method for obtaining the desired result.* They combine two pairs of antennæ (*AB* and *A₁B₁*, Fig. 419), each being of the form illustrated in Fig. 418, so that their planes are at right angles to each other. Similarly the coupling coils *S'* and *S''* (Fig. 419) are arranged so as to be perpendicular to each other. The coil *S*, which is part of the condenser circuit *CS*, used for excitation, can be *rotated* within the coils *S'* and *S''*.

If, then, the distance *d* between the antennæ is small compared to the wave-length ($d \leq \frac{\lambda}{6}$) [Art. 196*b*] a very simple calculation³⁰⁹ will bring out the following facts:

1. The direction of maximum range lies in the same plane as coil

* A. BLONDEL³¹⁰ has also proposed other methods for securing the same results.

S ;* the amplitude of the waves in this direction is always equal to the maximum amplitude of a single pair of the antennæ, independently of the position of S .

2. The distance effect diagram has the same form, that of Fig. 410, for all positions of S , and consists of two tangent circles, whose line of centers lies in the plane of coil S .

But if the distance between the antennæ is greater, d being from $\frac{\lambda}{6}$ to $\frac{\lambda}{2}$, then condition 1 is retained, *i.e.*, the direction of maximum range lies in the plane of S * and can be varied at will by rotating S , the

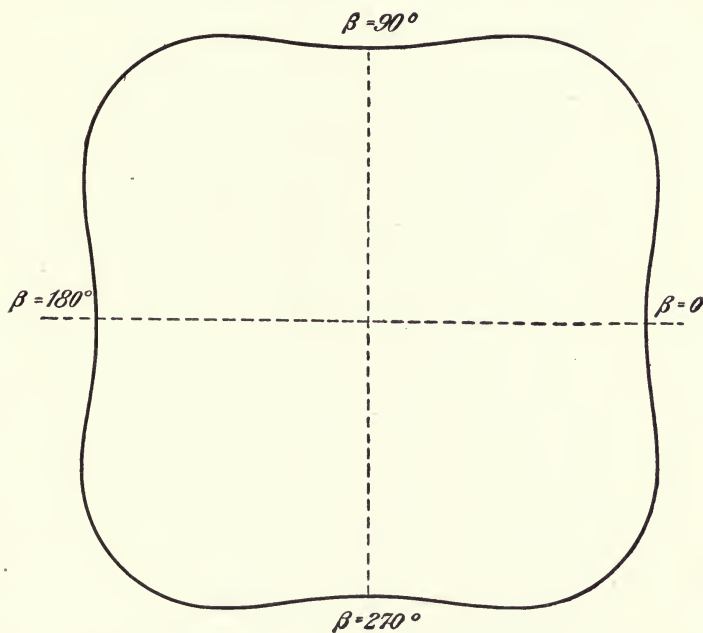

FIG. 420.

maximum amplitude does not remain constant for all positions of S ; in fact it has its greatest value for $\beta = 45^\circ$ and $\beta = 135^\circ$ and its minimum for $\beta = 0^\circ$ and $\beta = 90^\circ$ † [see Fig. 420, which gives the maximum amplitudes for all the different positions of S , *i.e.*, different values of β (Fig. 419)]. The distance effect characteristic is also changed somewhat, in

* When these antennæ are mounted on shipboard, the metallic masses in the ship and particularly the rigging are apt to affect the distribution, so that the direction of the maximum wave amplitude no longer coincides with that of coil S . Then empirical calibration of the radio-goniometer is necessary (see what follows).

† The maximum amplitudes for these two cases differ by 8 per cent. when $d = \frac{\lambda}{4}$ and by 24 per cent. when $d = \frac{\lambda}{2}$.

this case, as the position of S is varied. This, however, is not of great practical importance.*

BELLINI and TOSI have combined the two coupling coils, S' and S'' together with the movable coil S , in a single apparatus called the transmitting "radio-goniometer" (Fig. 421). The two coils S' and S'' (Fig. 419) are wound on a cylinder inside of which S rotates.

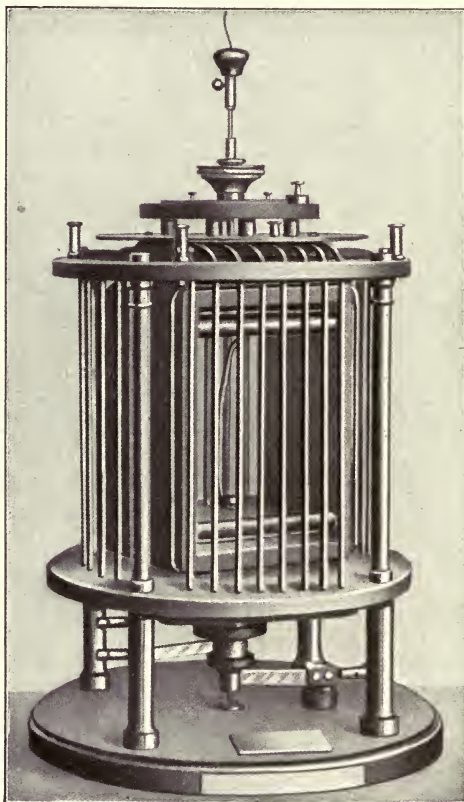

FIG. 421.

For the *reception* of waves tuned to the goniometer, the so-called "receiving radio-goniometer" is used, which is the same in principle as the transmitting goniometer, but whose coils are wound with a different number of turns. The movable coil is joined to a detector circuit. A simple consideration of the action of the transmitting goniometer with the conditions reversed for reception makes it evident that the receiving goniometer will respond with the greatest intensity to waves approaching

* If the antennæ and the exciting condenser circuit are closely coupled, two waves will in general be transmitted; their frequency, however, is not changed as the position of S is varied.³⁰⁹

in the direction of the plane of the movable coil and that it will fail to respond when this direction is perpendicular to the approaching waves.

The methods of BELLINI and TOSI have been put to extensive practical tests in France and seem to have given very satisfactory results. A large station has been erected on this principle at *Boulogne*. The aerials

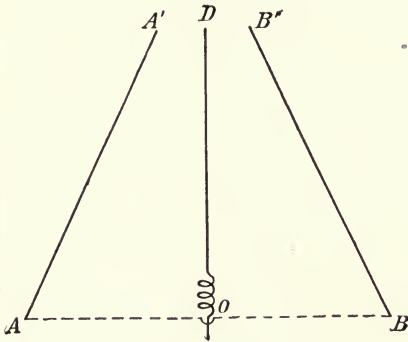

FIG. 422.

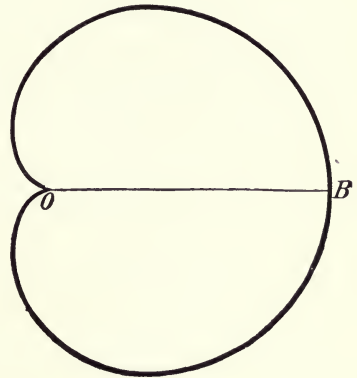

FIG. 423.

are supported by means of 4 steel towers, are 36 m. high, 80 m. apart at the top and 127 m. apart at their bases. The horizontal portions (*AB*, Fig. 418) are 8 m. above the ground and the wave-length is 300 m. The Boulogne Station has communicated at night, using only 0.5 kw. energy with Algiers (1500 km.) [See Art. 145f in this connection.]

c. The distance effect characteristic of the double antennæ discussed in *a* and *b* has the disadvantage of being bilateral, *i.e.*, the effect in any two directions 180° apart is alike. A unilateral characteristic is secured by placing a simple vertical antenna in the center of the pair of antennæ shown in Fig. 418, thereby obtaining the arrangement illustrated in Fig. 422. If the current in this middle antenna is in phase with that in antenna *BB'*, the effect in the direction *OB* is strengthened, while that in direction *OA* is weakened; under suitable conditions, therefore, a distance effect characteristic of the form of Fig. 423 is obtained, *i.e.*, the amplitude has a decided maximum in direction *OB* and a decided minimum in direction *OA*.

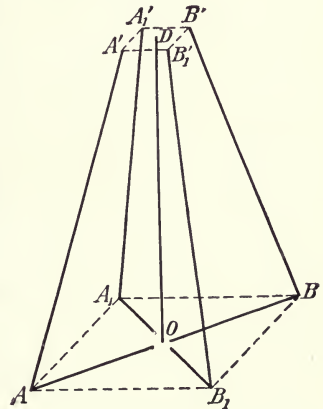

FIG. 424.

If it is desired to make the direction of maximum amplitude of this arrangement *variable* at will, the principle discussed in *b* can be directly

applied for this purpose; to the radio-goniometer with its two pairs of antennæ and their fixed coupling coils S' and S'' (Fig. 419) there is added a simple vertical antenna (OD , Fig. 424) whose coupling coil is *mechanically joined to the excitation coil S* (Fig. 419) and, therefore, turns with S . This offers a simple means of varying the direction of maximum radiation at will, the distance effect characteristic being of the form shown in Fig. 423.

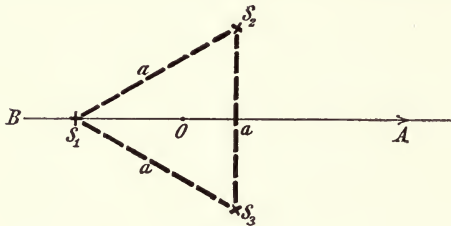

FIG. 425.

in the central vertical antenna would not be in phase with one of the inclined antennæ. This must therefore be taken into consideration.

199. The Methods of F. Braun.³¹¹—One of the methods with which F. BRAUN experimented in 1906 is illustrated in Fig. 425. The oscillations in antennæ S_2 and S_3 are in phase with each other, while those in antenna S_1 are displaced 270° from the others. The amplitudes in the three antennæ are proportioned as follows: $A_1:A_2:A_3 = 1:0.5:0.5$; the distance, A , between them is $\frac{\lambda}{4}$. Calculating the values for the characteristic in this case (on the assumption of ground of very high conductivity), the curve b of Fig. 426 is obtained, *i.e.*, there is maximum radiation in the direction OA and zero radiation in the opposite direction OB . This was borne out in the tests made by the very strong effect obtained in direction OA . In the opposite direction, however, the effect, though very slight, did not entirely disappear.*

Theoretically, even more advantageous characteristics for directive signaling are obtained by means of four antennæ suitably arranged (curve c , Fig. 426).

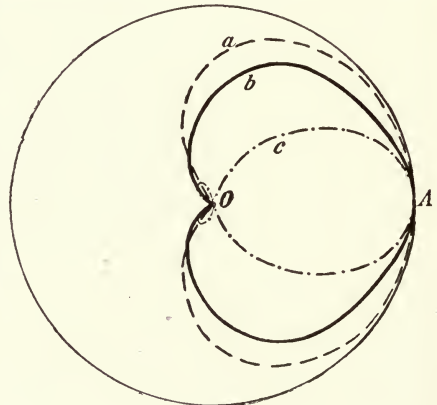

FIG. 426.

200. Production of any Desired Phase Difference with Undamped Oscillations (G. E. PETIT³¹²).—In the methods of BRAUN, as well as

* In one test, *e.g.*, the deflection of the measuring instrument used in the receiving set was 30 scale divisions in direction OA and only 2 scale divisions in the opposite direction.

in those discussed in Art. 196*c*, the chief difficulty consists in exciting oscillations of a certain desired phase difference in the transmitters.*

This problem can be solved very easily, at least in principle, in the case of undamped oscillations.

An arrangement suitable for this purpose is sketched in Fig. 427. The primary condenser circuit $\overline{C_1S_1S'_1}$, in which undamped oscillations are induced by means of a high frequency generator or the arc method, acts inductively (coupling coils S'_1 and S'_2) upon a second condenser circuit $\overline{C_2S_2S'_2}$, which is in resonance with $\overline{C_1S_1S'_1}$. Consequently undamped oscillations are induced in the secondary circuit $\overline{C_2S_2S'_2}$, but these are 90° out of phase with those in circuit $\overline{C_1S_1S'_1}$.

The planes of the two coils S_1 and S_2 are at right angles to each other. As the currents flowing through S_1 and S_2 are 90° out of phase, a rotating magnetic field is produced in the space surrounding these coils; this field is circular in form if the dimensions and coupling of the two condenser circuits are so chosen that the magnetic fields of each of the coils S_1 and S_2 are equal in amplitude. If, now, two other coils, S_3 and S_4 , having an angle ϕ between their planes, are inserted in this rotating field, electro-motive forces, having a phase difference ϕ , will be induced in them.

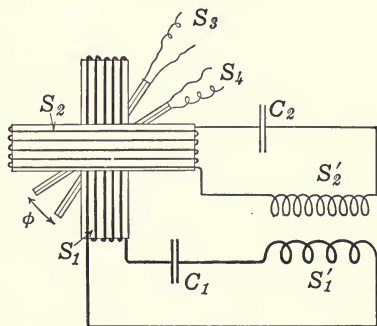

FIG. 427.

Hence, if S_3 and S_4 are each connected to one of two similar antennæ, the currents in the latter will also have a phase difference ϕ .

The amplitudes of the two antenna currents thus obtained can also be given any desired ratio by choosing the number of turns of the two coils S_1 and S_2 accordingly.

201. Production of any Desired Phase Difference with Damped Oscillations.—This far more difficult problem has been solved by L. MANDELSTAM and N. PAPALEXI,³¹³ whose method will be understood from the following consideration.

a. Let the condenser circuit $\overline{FC'AC_1BC''F}$ (Fig. 428) be caused to oscillate. Let V represent the voltage between points B and A , V_1 the voltage across the terminals of condenser C_1 , ε_i the e.m.f. induced along $\overline{AL'_1C_1L''_1B}$. Then, if the ohmic resistance is very low, $V = V_1 + \varepsilon_i$ approximately.

V_1 leads the current—which is marked i in Fig. 429 and the following

* The method customary in alternating current practice (light and power)—viz., branching off between inductive and non-inductive resistance—is not applicable in this case, as the non-inductive resistances would have to be so great as to increase the damping far beyond permissible limits.

figures—by 90° and ϵ_i lags behind the current by 90° . Their curves are, therefore, about as shown in Fig. 429.

b. Now let the points A and B be connected through a coil of very great self-induction. The rapid oscillations of the condenser circuit then continue just as if this coil were not there [Art. 41b]. But during the time in which the condenser circuit is being charged by the induction coil (or transformer) the coil between A and B acts as a short-circuit across con-

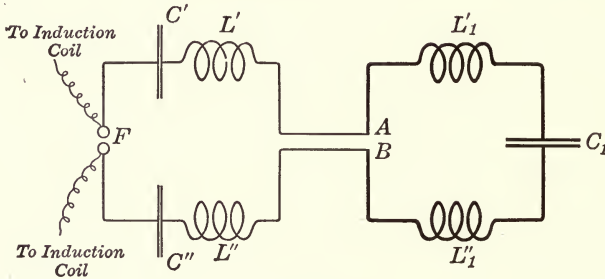

FIG. 428.

denser, C . Hence, the potential V_1 must have an initial value of zero, and cannot start at its maximum as shown in Fig. 429.

Moreover, a constant potential whose amplitude is equal to the maximum amplitude of the variable or alternating potential V_1 of Fig. 429 is added to the latter, so that curves V and V_1 are raised, appearing as in Fig. 430 if $V_{10} > \epsilon_{i0}$, and otherwise as in Fig. 431. In the first case, when $V_{10} > \epsilon_{i0}$, which is equivalent to stating that $\frac{1}{\omega C_1} > \omega L_1$, i.e., the

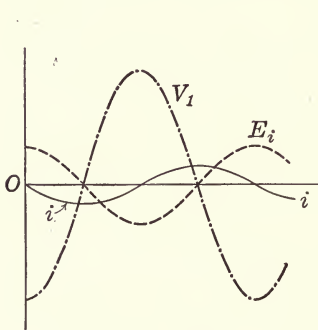

FIG. 429.

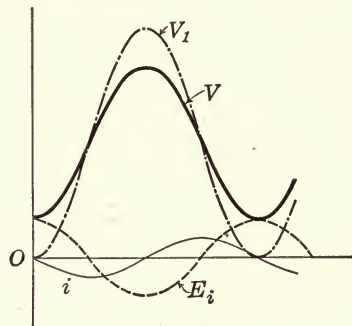

FIG. 430.

condensance of circuit $\overline{AC_1B}$ is greater than its inductance, it is essential for what follows that the *maximum of potential V occurs after half a period of the condenser circuit $\overline{FC'AC_1BC''F}$* . In the second case, which is of no interest in regard to what follows, the maximum of potential V occurs immediately after the beginning of the oscillations.

c. Let another condenser circuit, II , be added to the arrangement of

Fig. 428, as shown in Fig. 432. Spark gap F_1 is so adjusted in length that sparks are just able to jump across it whenever a spark passes across F . Condenser circuits I^* and II are tuned to be in resonance with each other.

Then if a spark jumps across F , condenser circuit II and condenser circuit $\overline{FC'AC_1BC''F}$ will oscillate simultaneously. But the spark at F_1 and, therefore, the natural oscillations of condenser circuit I do not begin until the potential V_1 at F_1 has reached its maximum, *i.e.*, until half a period of condenser circuit $\overline{FC'AC_1BC''F}$ has elapsed. As the natural period of this condenser circuit can be adjusted within certain limits by varying the coils $L'L''$, we have in these a means of controlling the time (within those limits) which will elapse before the oscillations of condenser circuit I commence after those of circuit II have started, *i.e.*, the means of giving the oscillations of circuit I any desired phase displacement (within certain limits) from those of circuit II .

d. For carrying this method out in practice, the following points should be noted:

1. Above all the condition that $\frac{1}{\omega C_1} > \omega L_1$ must be secured. For this is equivalent to making the frequency of condenser circuit $\overline{FC'AC_1BC''F}$ less than that of condenser circuit I [Art. 5a].

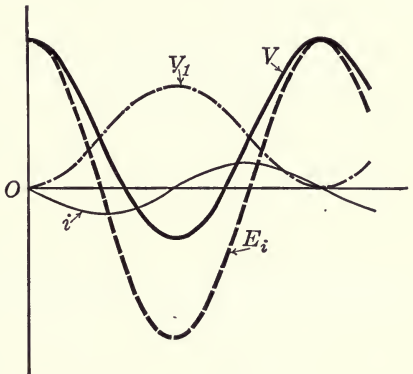

FIG. 431.

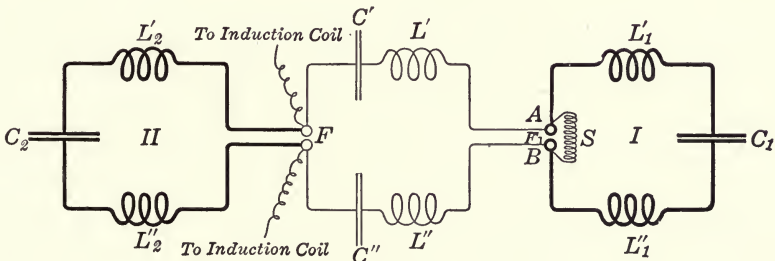

FIG. 432.

2. It is advantageous to have the resultant capacity of condensers C' and C'' equal to that of C_1 and of C_2 , as this makes the efficiency of the entire system a maximum.

3. The three parts into which the system divides itself must have

* That is $F_1L'_1C_1L''_1F_1$.

no appreciable inductive effect upon one another. Otherwise the various reactions which occur would be far more complicated than as stated above.

4. To insure prompt sparking at F_1 as soon as the potential there is at its maximum, it is advisable to let the ultra-violet rays from spark gap F fall upon gap F_1 or use some other means of ionizing gap F_1 [Art. 42b].

3. AERIALS HAVING HORIZONTAL OR INCLINED PORTIONS

202. Marconi's Bent Antenna.—MARCONI³¹⁴ approached the problem of directive signaling in a way quite different from any of the methods described in 2.

His method is to use an aerial consisting of a short vertical and a long horizontal portion, which in its simplest form appears as shown in Fig. 433.*



FIG. 433.

The mere fact that MARCONI has shown that, at a distance

of about one wave-length, this transmitter has a characteristic of the form of Fig. 434† proves nothing (according to Art. 92c) in regard to the effect at great distances. However, MARCONI has demonstrated by means of long distance tests, that this form of transmitting aerial has a much greater effect in direction AC than in the opposite direction and has a particularly small effect in the direction perpendicular to the plane of the aerial. Hence the *characteristic* at great distances must also have a greater length (vector) in the direction AC than in the opposite direction.

Fig. 435‡ is a sketch of the actual construction of an antenna of the type of Fig. 433, as used by MARCONI for his transatlantic stations.§ The fact

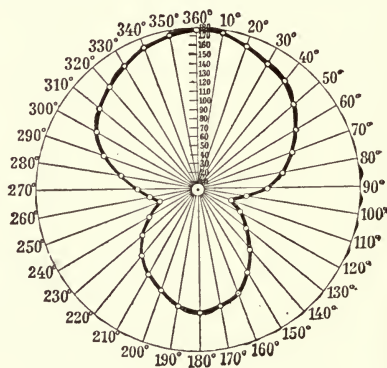

FIG. 434.

* When MARCONI'S experiments were made, it was found that the best results were obtained when the horizontal portion of the aerial was one-fifth of the wave-length. Fig. 434 is the characteristic under this condition.

† From Proc. Royal Soc., A77, p. 415, 1906. The direction marked 360° corresponds to the direction AC in Fig. 433.

‡ From the Jahrbuch für drahtl. Tel., 1, 608, 1908.

§ The Clifden station is reported³¹⁵ as having 30 masts each 60 m. high, between which 200 parallel wires are stretched over a length of 2000 m. and a width of 330 m. The fundamental wave-length of this antenna is said to be 4000 m. Later reports state that MARCONI now employs separate transmitting and receiving antennæ in his transatlantic stations. The transmitting aerial is said to be 600 m. long, the re-

that MARCONI has adopted this form for his transatlantic stations is perhaps the best evidence of its merits.

203. The Action of the Bent Marconi Antenna when Transmitting.—

a. The action of the MARCONI antenna can not be explained as long as we retain the assumption of perfect conductivity for the earth.

For under this assumption we would be justified in replacing the transmitter of Fig. 433 and the effect of the earth by the double trans-

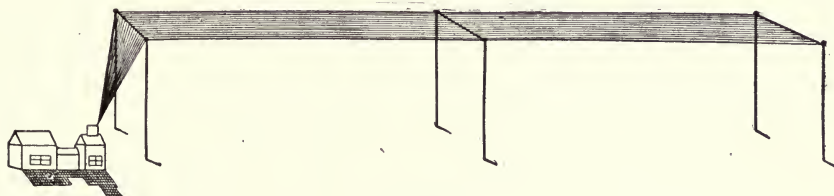

FIG. 435.

mitter of Fig. 436 without any ground [Art. 138*a*] and in calculating the field of this transmitter from the effect of the individual current elements of the antenna [Art. 25*b*]. With a flat earth's surface the field in the equatorial plane is the important factor. But in the equatorial plane the fields due to the horizontal portions of the antenna (Fig. 436) tend to neutralize each other as the distance from the transmitter increases. At *very* great distances, which of course are always in question in wire-

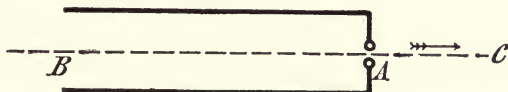

FIG. 436.

less telegraphy, practically nothing remains except the effect of the vertical portion of the antenna, and this is the same in all directions in view of the symmetry of the vertical portion. Under these conditions, therefore, this transmitting antenna could not be used for directive signaling.

From this it follows, on one hand, that the bent MARCONI antenna can have little or no directive power when located over sea water, *i.e.*, on shipboard,* and would radiate uniformly in all directions.

On the other hand, the directive power which this antenna *actually* has when used on land, can be explained only by taking the action in

ceiving aerial 1800 m. long and only 2-4 wires are used. [Translator's Note.—The MARCONI Co. has adopted separate transmitting and receiving stations for all its new transatlantic stations, as *e.g.*, New Brunswick and Belmar.]

* Or rather, to be more exact, on a wooden raft; for the metal rigging of a modern ship affects the radiation and destroys its uniformity.

the ground and the latter's conductivity and dielectric constants into consideration.

b. The first real explanation of the bent MARCONI antenna was given comparatively recently by H. VON HOERSCHELMANN,³¹⁶ a pupil of A. SOMMERFELD. His theory, based on the assumption of homogeneous ground in the vicinity of the transmitter in both horizontal and vertical directions may be developed as follows:

The action of a *horizontal* antenna stretched out over ground of moderate conductivity, consists in its inducing powerful earth currents in its immediate vicinity in the upper strata of the earth. The amplitude of the vertical components of these currents has a sharply defined maximum at a certain distance to either side of the middle of the antenna (in the plane of the antenna) and the phases of the vertical component currents to the right and to the left of the middle point are opposite. In accordance with the theory, we may now consider all the vertical components of the earth currents as being concentrated at the two maximum points mentioned above and the entire action then proceeds as if two simple wave series were being radiated from two vertical antennæ erected at the two points of maximum and whose currents

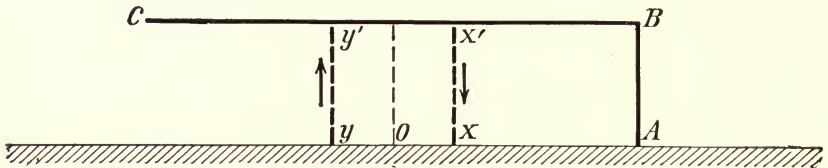

FIG. 437.

were opposite in phase. *This imaginary vertical double antenna in short is, so to say, automatically produced in the ground by the horizontal transmitting antenna.*

The field of the bent MARCONI antenna as can be shown from the theory, is easily calculated by superimposing the field of the vertical portion AB (Fig. 437) upon that of the two imaginary antennæ XX' and YY' produced by the horizontal portion BC , both being calculated according to the rules of Art. 25, just as if the conducting earth were not present.

This system of antennæ therefore resembles the arrangement discussed in Art. 198c, *the combination of a simple vertical antenna with a pair of antennæ oscillating in opposite phases.* But in the case before us the distance $d = XY$ between the pair of antennæ, is not optional, being in fact equal to the height h ($= AB$ Fig. 437) of the MARCONI antenna. Moreover, the phase of the oscillations in the double antenna is not the same as (nor opposite to) that of the oscillations in antenna AB , but the oscillations in XX' lag 45° behind those in AB . Finally, the amplitudes of the waves radiated by each of the imaginary pair

of antennæ XX' and YY' though equal to each other, are not equal to the amplitude of the wave radiated by antenna AB . Denoting the former amplitude by E_{f_0} and the latter by E_{h_0} , their relation is given by*

$$E_{f_0} = E_{h_0} \cdot \frac{l}{h} \cdot 2\pi h \sqrt{2\sigma\lambda c} \tag{1}$$

The two imaginary antennæ according to Art. 196*b* produce a field whose amplitude at a very distant point P^* is

$$E'_0 = 2E_{f_0} \cdot \frac{\pi d}{\lambda} \cos \lambda = 2E_{f_0} \cdot \frac{\pi h}{\lambda} \cos \vartheta \dagger \tag{2}$$

If we superimpose the wave radiated by this imaginary double antenna upon that radiated by the vertical antenna, keeping the 45° difference in phase in mind—we obtain the amplitude of the resultant wave,

$$\left. \begin{aligned} E_{r_0} &= \sqrt{E_{h_0}^2 + E'^2_0 + 2E_{h_0}E'_0 \cos 45^\circ} \\ &= E_{h_0} \sqrt{1 + \beta^2 \cos^2 \vartheta + \sqrt{2} \cdot \beta \cos \vartheta} \end{aligned} \right\} \tag{3}$$

in which
$$\beta = \frac{l}{h} \cdot \frac{1}{\sqrt{2\sigma\lambda c}}$$

This relation determines the distance effect characteristic of the bent transmitting antenna. Its form depends upon the value of β , *i.e.*, aside from the wave-length, it depends mainly upon the ratio of the length of the horizontal portion of the antenna to the vertical portion and upon the conductivity of the ground. In Fig. 438 the distance effect characteristics are shown for $\beta = 4\dagger$ (heavy full line curve *b*) and for $\beta = 1.4§$ (lighter curve *c*); they correspond to ground of poor conductivity. The former, *b*, is very similar to that observed experimentally by MARCONI (Fig. 434); the theory therefore gives results which agree well with the actual facts. The maximum directive power is obtained when $\beta = 1$ (characteristic very similar to curve *c*); with $\beta = 0.2$ the characteristic (dot-and-dash curve *d*, Fig. 438) has already lost its directive form to a very large extent.

If the conductivity of the ground is very great, making β very small, then, in equation (3) the first term under the radical sign becomes

* Under the following assumptions:

1. Height, h , and length, l , of the antenna $\ll \lambda$.

2. The expression $\frac{2\lambda\sigma c}{k} \gg 1.0$ [where σ = specific conductivity of the ground, V_L = velocity of light and k = dielectric constant of the ground, all in c.g.s. units]. This assumption is always correct for the conditions encountered in practice.

† $\angle POA = \vartheta$ [see Art. 196].

‡ Corresponding, *e.g.*, to : $\sigma = 1.2 \times 10^{-16}$ c.g.s. units;
 $\lambda = 2000$ m.;
 $l/h = 5$.

§ Corresponding, *e.g.*, to : $\sigma = 10^{-15}$ c.g.s. units;
 $\lambda = 2000$ m.;
 $l/h = 5$.

the determining factor and, as was to be expected from a , E_{r_0} becomes equal to E_{h_0} , *i.e.*, the distance effect becomes virtually identical with that of the vertical portion AB (Fig. 438, curve e). In the other limiting case, if β is very great—say the horizontal portion is very much longer than the vertical part of the antenna—the effect of the horizontal portion predominates and the form of the characteristic approaches that of a pair of antennæ with currents of opposite phase (Fig. 438, curve a ; compare Fig. 410), *i.e.*, the antenna radiates about equally in directions AB and AC of Fig. 433, but only very slightly in the direction perpendicular to AB and AC .

c. It follows, therefore, that in order to operate directly, the bent MARCONI antenna must be placed over ground of low conductivity;

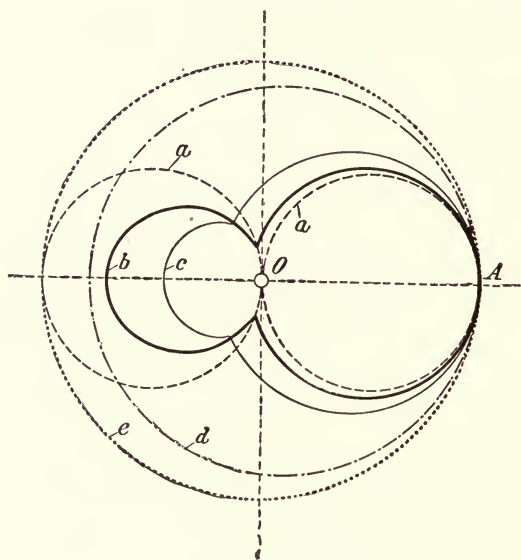

FIG. 438.

the directive power is the result of the earth currents. In this respect then the bent antenna differs fundamentally from the arrangements employing several antennæ with currents displaced in phase, as discussed in 1. The latter have directive power no matter what the nature of the ground, retaining it even when used on shipboard over sea water. However, with the bent MARCONI antenna it suffices if ground of low conductivity surrounds the antenna for only a comparatively short radius to secure the directive power. It seems that, once the waves have developed a directive distribution in the vicinity of the transmitter, they will retain this in passing over ground of high conductivity, as in traveling over sea, later on. In regard to the propagation of directed waves, the same conditions (absorption, direction of the field at the

earth's surface) hold as for waves radiated uniformly in all directions [Art. 139 *et seq.*].

204. The Bent Marconi Antenna used for Receiving.³¹⁷—*a.* In his long distance experiments, MARCONI found³¹⁴ that his antenna responded far better to waves approaching in the direction of the arrow in Fig. 439 than to waves traveling in the opposite direction; the effect of waves approaching in a direction perpendicular to the plane of the antenna was intermediate between that of the other two extreme cases.

In other tests that were made the difference between the effect of waves having the direction of the arrow in Fig. 439 and waves having the



FIG. 439.

opposite direction was but very slight; but waves approaching perpendicularly to the plane of the antenna had only very little effect in comparison.

b. No complete explanation of the action of the bent MARCONI antenna when receiving has been given to date. Not only the effect of the electromagnetic waves in the air upon the horizontal and vertical portions of the antenna, but also the effect of the field of the waves in the earth upon the earth currents, which according to Art. 203 form a material part of the natural oscillations of these antennæ, would have to be considered in seeking an explanation. If it were possible in this case to substitute the action of two imaginary antennæ for that of the earth field, as was done in Art. 203*b*, the problem would become relatively simple. This substitution, however, is not clearly justified in this case.

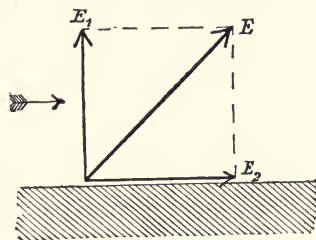

FIG. 440.

A qualitative explanation of the action of the bent antenna when receiving, as found from the test, can be obtained by simply considering the effect of the field in the air upon the horizontal and vertical portions of the aerial proper (J. ZENNECK³¹⁷).

1. In order to simplify the conditions involved as much as possible, let us first assume that the electrical field produced by the transmitted waves is an *alternating field whose direction is inclined at a considerable angle to the vertical direction* [Art. 139*e*]. Let this direction be that of *E* in Fig. 440. *E*₁ and *E*₂ are respectively the vertical and horizontal components of the electric field strength. The potential difference produced in the antenna by this field is made up of the potential along

AG (Fig. 441), which is produced entirely by the vertical component, E_1 , and that along GH , which is produced solely by the horizontal component, E_2 . As, under our assumption, the vertical and horizontal components are in phase, the potentials across AG and GH are added, *i.e.*, the amplitude of the potential difference along the entire antenna $AGH =$ the *sum* of the amplitudes of the potential differences induced in the horizontal and vertical portions of the antenna.

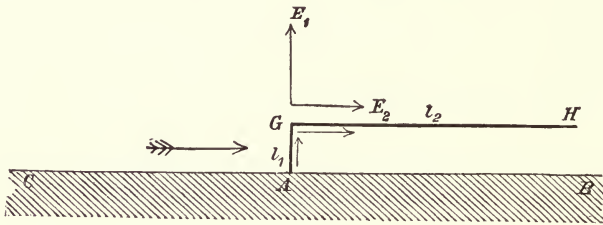

FIG. 441.

But if the antenna is turned through an angle of 180° , as shown in Fig. 442, then the amplitude of the total potential difference along $AGH =$ the *difference* between the potentials induced in the vertical portion, AG , and the horizontal portion, GH .

Finally, if the receiving antenna is so placed that its plane is perpendicular to the direction of propagation of the waves, the horizontal component, E_2 , has no effect at all and only the effect upon the vertical portion, AG , remains.

We can distinguish between two general cases:

α . The potential induced in the horizontal portion, GH , is *smaller* than that induced in the vertical part, AG . Then, from what has pre-

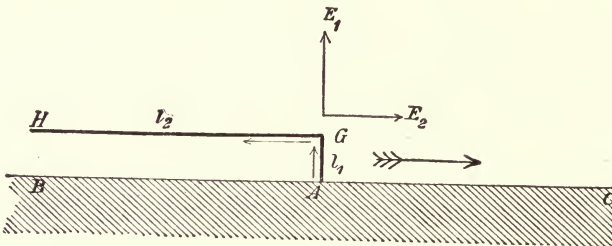

FIG. 442.

ceded, it follows that the incoming wave must have a maximum effect upon the receiver in the position of Fig. 441, a minimum in that of Fig. 442 and effects intermediate between these limits when the plane of the antenna is perpendicular to the direction of the approaching waves.

β . The potential induced in the horizontal portion is considerably

greater than that induced in the vertical part. Then the effects for the two positions of Figs. 441 and 442 will differ only slightly, but will be greatly reduced when the antenna plane is perpendicular to the direction of the approaching waves.

2. If the electric field at the surface of the earth is not a pure alternating field, but has a more or less prominent rotating component [Art. 139e], then the horizontal and vertical components of the field are no longer in phase. However, as this phase difference lies between 0 and 45° , the results of 1 remain qualitatively unchanged. But the difference in the effects obtained in the two chief positions (Figs. 441 and 442) becomes less and less as this phase difference increases.

c. The characteristic of this* type of directive receiving antenna depends upon the relation of the effect upon the horizontal portion to the effect upon the vertical portion. This in turn depends upon:

1. The ratio of the length of the horizontal to that of the vertical portion of the antenna.

2. The nature of the ground, inasmuch as this determines the amplitude ratio of the vertical and horizontal field components as well as the phase displacement between these components [Art. 139e].

If the antenna is located over sea water† the effect produced upon it can depend very little, if at all, upon the position (direction) of the antenna; in short it is no longer directive. For in this case, according to

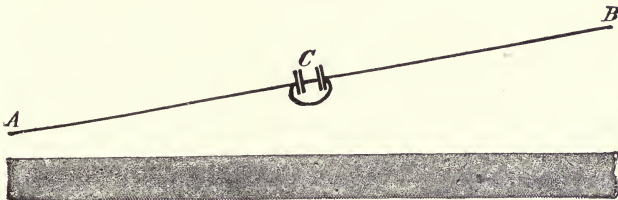

FIG. 443.

Art. 138c, the horizontal field component vanishes to an infinitesimal value as compared to the vertical component, so that the effects upon the horizontal and vertical parts of the antenna bear the same relation to each other.

205. Inclined Antennæ.—*a.* As early as 1902, F. BRAUN,³¹¹ conducted successful experiments with an antenna of the form shown in Fig. 443 (*AB* is the antenna, *C* is a condenser circuit tuned to it and directly coupled with it). The angle between the antenna and the horizontal earth's surface was about 5° . It was found that this form of receiving

* Other types of directive receiving antenna can be explained in a similar manner.

† If the antenna is on board a ship, the metallic masses of the latter are apt to cause considerable distortion of the electric field, so that the simple conditions assumed above no longer hold true.

antenna responded with the greatest intensity to waves traveling in the vertical plane passing through the antenna and was only very slightly affected by waves approaching in a direction perpendicular to this plane.

b. Since these early experiments, frequent observations have been made in practice of the fact that, *e.g.*, harp or fan-shaped antennæ which are suspended at an angle from the two towers which support them,* respond much better, when receiving, to waves having the direction of the arrow in Fig. 365 than to waves approaching in other directions and when transmitting, the amplitude of the waves radiated is greatest in the direction opposite to that of the arrow in Fig. 365.

c. An *explanation* of the directive power of these antennæ when *receiving* can at once be found in the fact that for waves traveling along ground of low conductivity, the direction of the electric field instead of being vertical, is inclined toward the earth's surface [Art. 139e] and that any antenna must respond to the greatest extent when its direction coincides with that of the field acting upon it† [Art. 171].

The directive power of these inclined antennæ when *transmitting* can probably be explained similarly to that of the bent MARCONI antenna when transmitting. We may assume that the distance effect of an antenna current inclined to the earth's surface can be split up into the respective effects of a vertical and a horizontal component current.

From the preceding it would be expected that the directive power of inclined antennæ, both when transmitting and receiving, vanishes when they are located over ground of very high conductivity.

206. Horizontal Antennæ, Ground Antennæ.—In the experiments of F. BRAUN (Art. 205a), the slight inclination of the antenna toward the horizontal (Fig. 443) was of no material importance. Undoubtedly BRAUN would have obtained about the same results if the antenna had been exactly horizontal.

Such horizontal antennæ, which differ from the bent MARCONI antenna in consisting of two *symmetrical* halves at a slight distance above the ground, have recently been termed "*ground antennæ*".³¹⁸ They have been proposed by many others (*e.g.*, by MARCONI, L. ZEHNDER³¹⁸) besides BRAUN and have been tried out here and there. The general opinion seems to have been though that their effectiveness was so far below that of vertical antennæ as to eliminate them from practical use. In recent times, however, F. KIEBITZ³¹⁸ has shown that considerable ranges can be attained with these antennæ. Thus with a receiving aerial 240 m. long at Belzig, the signals of the station on the Admiralty Office in London could be clearly received (distance 880 km.; horizontal portion of receiving an-

* As for instance the antenna of the Eiffel Tower.

† This by no means applies to the antenna of Fig. 443; for its angle with the horizontal is so small that it comes mainly under the influence of the horizontal field component.

tenna 1 m. above ground). Messages from the same antenna when transmitting were easily received at Swinemünde, 230 km. away.*

The antennæ used by KIEBITZ consisted either of two free ended halves like that of BRAUN (Fig. 443), or each half was grounded at its end, *A* and *B* (Fig. 444) through a condenser.

The *action* of these antennæ (*i.e.*, their horizontal part) can undoubtedly be replaced, at least approximately, by the action of a pair of vertical antennæ whose currents are equal in amplitude but opposite in phase, according to Art. 203b.† They must transmit the maximum

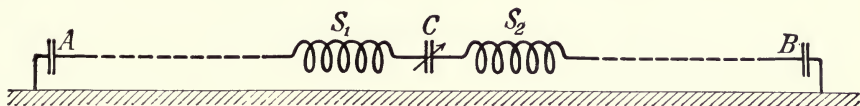

FIG. 444.

energy in the vertical plane passing through them and must receive with the greatest intensity waves whose direction of travel is in this vertical plane.

Such tests as have been made to date are not yet complete enough to permit the formation of any final conclusions as to the comparative relations between horizontal and vertical antennæ. Nevertheless it would seem safe to conclude from the results already obtained, that in certain special cases the vertical antenna can be efficiently replaced by the horizontal ground antenna.

207. The Advantages of Directive Signaling.—*a. Directive Transmitters.*—If the problem of directive signaling were solved, *i.e.*, if we had a transmitter which would radiate almost entirely in a single given direction, the following advantages would be secured.

1. In radio-telegraphy at present only that portion of the energy which is transmitted in the direction of the receiver appears to be useful. It follows that a directive transmitter, operating at the same efficiency (at the transmitter), would give the maximum amount of useful energy.³¹⁹

2. A directive transmitter would accomplish a great step forward in securing *secrecy of messages*. Assume *SA* (Fig. 445) to be the range of transmitter *S* for a given receiver *E*. If the transmitter is non-directive, *E* will be able to receive its signals anywhere within the circle drawn in Fig. 445. But if the transmitter is directive and has a characteristic as shown by the heavy line curve in the figure (which represents high

* In fact some of the signals from the MARCONI station at Glace Bay (Canada) seem to have been received with a low horizontal antenna about 1200 m. long.

† However, the various relations governing the amplitude of the oscillations in the two imaginary antennæ and the distance between them as given in Art. 203b can be applied to the present case only if the length of the horizontal portion is small compared to the wave-length (see foot-note, Art. 203b).

directive power), then E must be within the small shaded area to receive the signals from S .

3. For the same reasons, it is evident that with directive transmitters

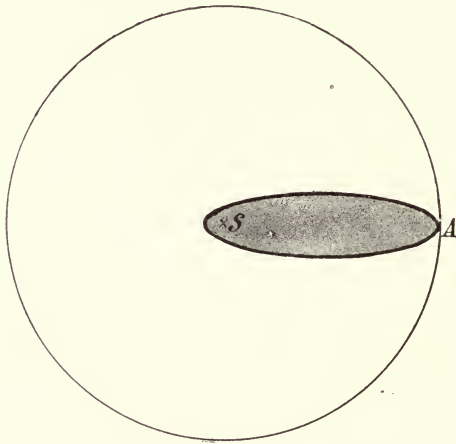

FIG. 445.

interference between various stations operating in the same zone is greatly reduced.

b. Directive Receivers.—1. Interference between neighboring stations can be reduced to an even much greater extent³²⁰ if directive receivers are

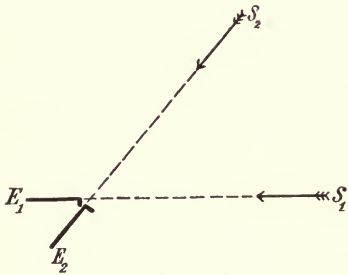

FIG. 446.

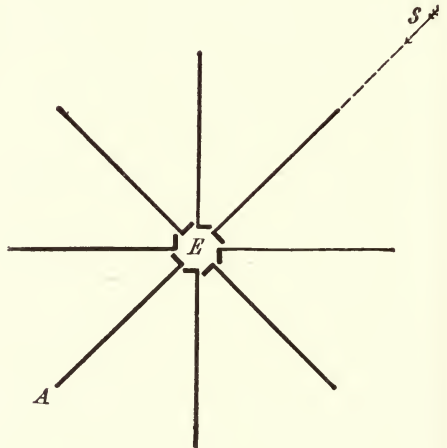

FIG. 447.

employed, that is if the receivers respond almost solely to waves approaching in the direction of the transmitting station with which communication is intended.

2. Operation with directive receivers offers another advantage. If a

station is equipped with two directive receivers, E_1 and E_2 (Fig. 446), each of which is differently directed, then messages can be received simultaneously from two different transmitters, S_1 and S_2 , even if these operate *at the same wave-length*.

This may be an important advantage in case both transmitting stations are obliged to operate at the same normal wave-length (as, *e.g.*, two light-ship stations) due to their both working with stations for which a definite wave-length is specified (*e.g.*, the ships of a fleet or the merchant marine).

3. Finally, the directive receiver offers a means of *determining the direction in which the transmitter is located*.

For this purpose, it would only be necessary theoretically—in practice this would involve great difficulties—to turn the receiver about a vertical axis; then the direction of the transmitter would be that in which the receiver responds with the greatest intensity.

Another method would be to have a complete circle of directive receivers (Fig. 447). Then if receiver EA is the only one to respond, or at least responds with maximum intensity, the transmitter must lie in direction ES . Thus if such a station is erected on land and a message is received by it from a ship at sea, this gives an immediate indication of the direction of the ship. MARCONI made a number of experiments along this line; it was found possible to determine with considerable accuracy the direction of ships about 90 km. from shore.³²¹

The BELLINI and TOSI apparatus* are particularly convenient for this purpose. The receiving radio-goniometer [Art. 198b] offers a direct means of determining the direction of approaching waves. The movable coil of the radio-goniometer is rotated until the signals in the receiver have their maximum intensity. As this maximum is not very sharp (see characteristics in Figs. 410 and 423), more exact results are obtained by finding the position of the movable coil in which the received signals vanish or have minimum intensity; the direction of the approaching waves is then perpendicular to this position of the coil.

But if the waves must travel over land for considerable distances none of these methods can be counted upon. For in that case, the assumption that the direction in which the waves approach the receiver is the same as that in which the transmitter is located with respect to the receiver, is not necessarily correct [Art. 143a].

c. Another problem in directive radio-signaling, which has recently gained in importance is the following: Given two fixed land stations of known location and a moving station (ship, balloon, aeroplane); *to determine the location of the latter at any instant*.³²⁴

*They seem to be giving very good results. BELLINI and TOSI claim that by means of the antennæ described in Art. 198c (combination of symmetrical and double antenna) the direction can be determined within 1° . P. BRENOT reports that the direction of ships 300 km. away, could be determined within 4° to 5° .³²²

1. One solution is to equip the moving station with a directive receiver and by means of this determine the direction of approach of the waves from each of the fixed stations. The BELLINI and TOSI* method is well suited for such receivers, while the double antenna, with the two antennæ half a wave-length apart, seems well adapted for use on dirigible balloons [Art. 96a (4)]. These methods, however, involve considerable practical difficulties, particularly because they are suitable for short wave-lengths only, so that a separate receiver becomes necessary for the longer waves used in regular service.

2. A second solution of the problem is as follows: The *fixed* stations are provided with a directive receiver. The moving station must then call the fixed stations to determine its own position. The latter then each find the direction from which the waves radiated by the moving station come in, and inform the moving station of this direction. In this case of course the moving station does not require directive apparatus for either transmission or reception.

3. Another solution was proposed some time ago by A. ARTOM^{324a} and was tried out later by the Prussian Ministry of Public Works. Each of the two fixed stations is provided with a set of directed transmitting antennæ by means of which waves can be radiated in any one of various, say 16, different directions. *The fixed stations radiate some signals (different for the two stations, as, e.g., two different letters) in each of the 16 directions consecutively.* The moving station, which is equipped with an ordinary non-directive receiver, determines which signal comes in with the greatest intensity. Thus if, *e. g.*, this is the letter "a" and the moving station knows that this "a" is being sent out from the south-north transmitter of one of the fixed stations, the operator at the moving station concludes that he is in a direction north from that fixed station. The direction with respect to the other fixed station is then determined in a similar manner.

In the tests made near Berlin, 32 masts were erected at the transmitting station in a circle of about 200 m. diameter. Each mast supported an aerial, and the aeriels of each pair of diametrically opposite masts were joined by a horizontal conductor. As the latter was approximately equal to half a wave-length, each pair of antennæ comprised a radiating system of the type described in Art. 197a. The station building was located at the center of the circle, where the 16 double antennæ could be conveniently coupled with the primary circuit, one after another.

This method has been recently developed by A. MEISSNER (TELEFUNKEN Co.³²⁴) into a commercial form of apparatus (the "*Telefunken Compass*"). The directive transmitting antennæ, $CBAB_1C_1$ (Fig.

* BELLINI and TOSI have devised a compass system, for use in the vicinity of ports, by means of which incoming ships can find the entrance to the harbor through heavy fog (low power transmitter having 15 to 20 miles range).³²³

448), which are placed radially about the building of the fixed station *A*, are combinations of two bent MARCONI aeriæ. They are all supported by a single central mast, which also carries a non-directive umbrella

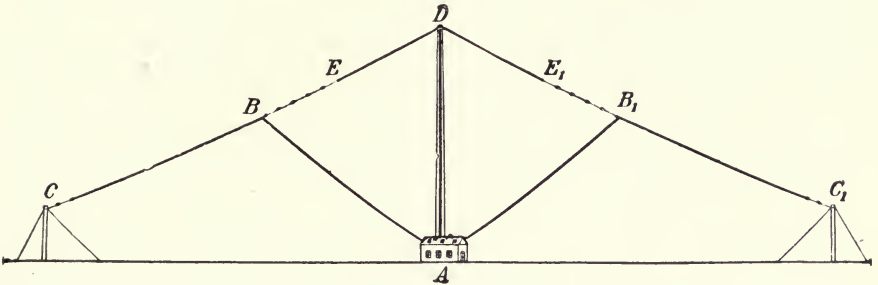

FIG. 448.

aerial, ADE_1E . By means of an automatic contactor (Fig. 449 shows the contact device with its driving motor and the contact points of the different antennæ at the top) first the umbrella aerial (time signal) and then each of the directive antennæ are in turn connected to the primary circuit at given equal intervals for excitation.

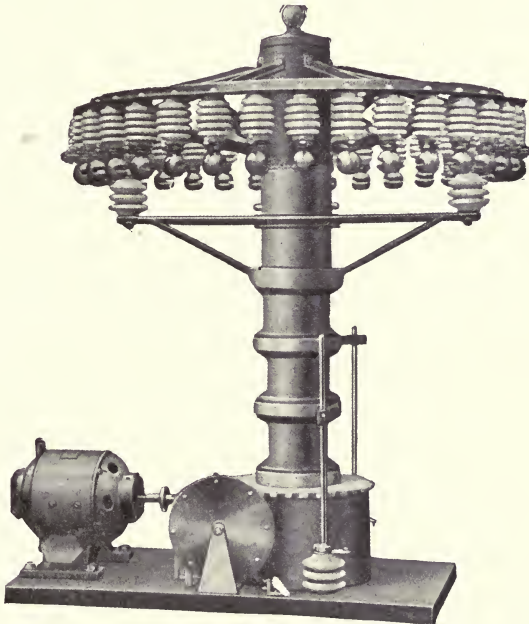

FIG. 449.

The moving station is provided with a stop-watch, of the form shown in Fig. 450, whose pointer makes one complete revolution in the same time ($\frac{1}{2}$ minute) which the contactor takes to connect all of the directive

transmitting antenna pairs once in turn. At the instant when the operator of the moving station hears the time signal (z,* Fig. 450), he presses his stop-watch and sets it going. He then stops it at the moment when the incoming signals are loudest;† then the position of the stop-watch pointer indicates the direction of that one of the double antennæ of the fixed station which is in line with the moving station at that in-



FIG. 450.

stant. If this procedure is repeated several times and the average of the stop-watch pointer positions noted, the direction can be determined within 4° to 5° .

In tests made with a mast 23 m. high and using about 0.5 kw. energy the direction of a balloon from the compass station was determined quite accurately up to a distance of 100 km.

*"z" is not shown in cut, but refers to point between 31 and 1 on the watch scale.

† As the maximum intensity is usually not very sharply defined, it is probably better to determine the position of *minimum* intensity.

CHAPTER XIV

WIRELESS TELEPHONY³²⁵

1. THE TRANSMITTER

208. Source of Energy.—Very soon after the earliest successes in wireless telegraphy, attempts were made to transmit speech by means of electromagnetic waves.

a. As long as *damped* oscillations with relatively low discharge frequency were employed, the results of such tests necessarily remained unsatisfactory. The essential requirement for good transmission of speech seems to be a discharge frequency considerably higher than the highest frequency of the tones used in speech.

Accordingly, only those methods which permit the use of very high discharge frequencies [Art. 111] come into consideration here. And with these methods fair results have been obtained by many investigators (FESSENDEN, AUSTIN, v. LEPEL and MAJORANA³²¹) some of whom used discharge frequencies as high as 10,000 per second. Even to the present day W. DUBILIER³²⁶ seems to be working with quenched gap transmitters, though, to be sure, he employs extremely high discharge frequencies.

b. *Undamped* oscillations, however, are by far more advantageous for radio-telephone work. From the very first R. A. FESSENDEN sought a practical solution of the problem along these lines, producing the undamped oscillations by means of a *high frequency alternator*. His first alternator operated at 80,000 cycles per second ($\lambda = 3750$ m.) and was of 1 kw. capacity. Even as early as 1904 the NAT. ELEC. SIG. Co., with which FESSENDEN was associated, guaranteed to establish wireless telephone communication over a distance of 25 miles (according to Mr. FESSENDEN).

POULSEN also promptly used his *arc generator* for wireless telephony; he, as well as others, *e.g.*, A. F. COLLINS, M. COLIN and R. JEANCE³²⁶ seem to have spent considerable effort in developing this phase of the work. The POULSEN stations in California have a range of 550 km., using ordinary microphones and with an antenna 94 m. high.³²⁷ The clearness of the reproduction of the transmitted sounds in the receiver has been praised in every test.

209. Connectors.—*a.* Wireless telephone transmitters all have a *microphone* into which is spoken. This microphone is usually connected in such a manner that its resistance variations, which follow the oscillations of the impressed sound waves, cause corresponding variations in the *amplitude* of the radiated waves.

This can be accomplished in a great variety of ways. The microphone can be inserted directly in the antenna, or with a coupled transmitter, in the primary circuit, or in the current supply circuit, or, finally, in the excitation circuit of the POULSEN arc field magnets, or the field circuit of the high frequency generator. Moreover it is not necessary that the microphone be inserted directly in any of these circuits; it can be placed in a separate circuit and the latter then be coupled to the

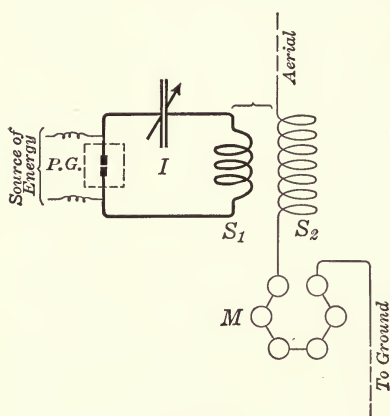

FIG. 451.

particular circuit which is to be affected by the action of the microphone. All these theoretical possibilities have been described as "inventions" in patent papers.

The arrangement most extensively used in actual practice is that of POULSEN³²⁸—a *coupled transmitter* and the *microphone*, or microphones, (M , Fig. 451) *inserted directly in the antenna*. With this arrangement the coupling between the primary circuit and the antenna should be as loose as possible.

In the arrangement of Fig. 451, as well as in the commercial form of this method shown at the right of Fig. 452, *several* microphones are used, all joined to a common mouthpiece. The object of this is mainly to make full use of the energy of the sound waves much of which would be lost with only a single microphone.

However, the use of several microphones connected in series may have still another purpose, namely, to bring the total microphone resistance to its most advantageous value. In order that the sounds are reproduced in the receiver with maximum clearness, the resistance of the microphone or equivalent resistance* of the microphone circuit must have a certain definite relation† to the effective resistance of the antenna. This relation can be obtained, aside from using several microphones, by the same means as were discussed in connection with the similar problem in Art. 178; that is, the microphone is put in a separate circuit whose coupling with the antenna can be varied at will, or only a part of the antenna current‡ is allowed to pass through the microphone,

* The equivalent resistance R of the microphone circuit is defined as the value of R in RI^2_{eff} , when this expression is equal to the energy delivered to the microphone circuit per second, I being the current at the base of the antenna.

† The change produced in the antenna current amplitude by a given change in the microphone resistance is greatest, in the arrangement of Fig. 451, if the microphone resistance is equal to that of the rest of the antenna.³²⁹

‡ Or, to make this more general, part of the current of that system which is to be affected by the changes in the microphone.

the latter being connected in parallel to a portion of the antenna inductance or to a condenser placed in the antenna.

b. Instead of varying the *amplitude* of the radiated waves by means of a microphone, attempts have been made to change the *frequency* of the waves by the microphone variations; the author, however, is not aware of any practical success in this direction.

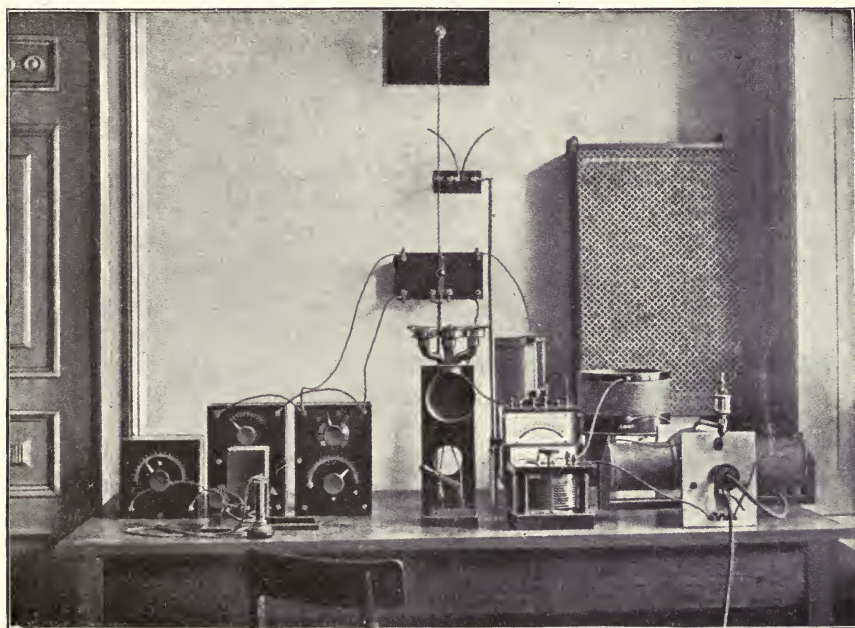

FIG. 452.

210. Microphones.—Whenever great ranges are required, so that a large amount of energy must be handled in the transmitter, it is in general impossible to avoid sending heavy currents through the microphone. This at once eliminates the ordinary microphones built for small currents. A great number of contrivances have been devised to meet this problem.

a. It has been proposed to constantly shake the microphones during operation, to prevent excessive local heating of the carbon particles. The same purpose is served by devices in which the microphone particles are set into very active motion by the sound waves. Then various air, oil and water-cooled microphones as, *e.g.*, the heavy current microphone of C. EGNER and J. G. HOLMSTROM³³⁰ have been devised.

b. The *hydraulic* microphone of S. MAJORANA³³¹ seems to have given particularly good results (Fig. 453).

A liquid flows from a tube R_1 , which has an elastic diaphragm at A

joined to the diaphragm M of the microphone, and impinges upon a plate P where it forms a thin liquid sheet or layer. This layer acts as a conductor between the metallic (platinum) plate P_1 and the metallic ring P_2 (P_0 is made of insulating material). As long as the diaphragm remains at rest the liquid flows in a fine even stream. But if the diaphragm is vibrated, the stream assumes contractions in unison with the vibrations, and the resistance of the sheet of liquid joining the two platinum electrodes P_1 and P_2 also varies in unison with the vibrations.

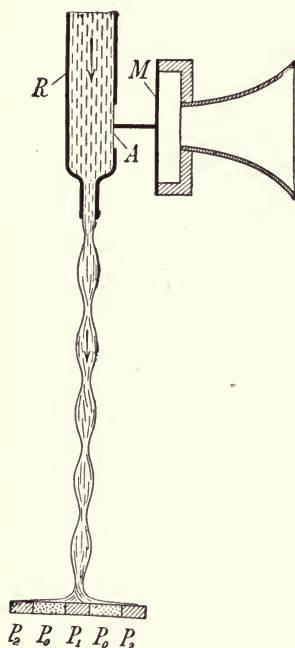

FIG. 453.

With this microphone, in conjunction with a POULSEN 500 volt generator, successful tests were conducted between two fixed stations of moderate size about 500 km. apart and between a fixed station and a torpedo boat destroyer station over 400 km. apart.

c. Another hydraulic microphone (Fig. 454) was devised by F. J. CHAMBERS.³³² Here the vibrations of diaphragm M vary the resistance of the very thin layer of liquid between M and the fixed tubular electrode E , which also serves

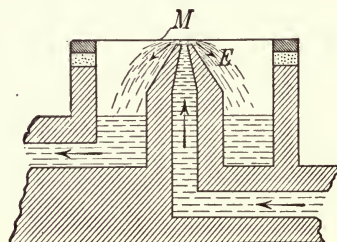

FIG. 454.

for feeding the liquid. This microphone is claimed to stand from 250 to 500 watts and to give very clear reproductions.

d. R. A. FESSENDEN³²⁵ has constructed a *telephone relay* which is claimed to allow the use of a current of 15 amp.

2. THE RECEIVER

211. Connections.—*a.* In general the receivers used for radio-telephony must meet the same general requirements as radio-telegraph receivers. The methods of connection consequently have little if any difference.

Formerly it was considered important to have very sharp tuning in the receiver, so that the resonance circuits in the receiver were designed with as little damping as possible.

Thus, the POULSEN³²⁸ method, shown in Fig. 455, is an example of

this class. Here the aerial is coupled with a condenser circuit C_1S_1 and this in turn with the condenser circuit C_2S_2 . In the latter the damping is intentionally kept low by connecting the detector Th in parallel with only a portion of the self-induction S_2 . The commercial construction of this arrangement is shown in Fig. 452 (left-hand side); the adjustable condenser at the extreme left is C_2 of Fig. 455, while that furthest to the right is C_1 and consists of an upper part adjustable in steps and a lower part continuously adjustable. Between these condensers are the coupling coils S_1S_2 which are arranged for adjustable coupling as shown in Fig. 382.

Very soon, however, low damping in the resonance circuits of the receiver was abandoned. It developed that the resonance action causes a distortion of the speech transmitted. This, in fact, is to be expected if we consider the relations discussed in Art. 67. The time variation of the amplitude in the resonant system in general follows the time variation of the amplitude in the exciting system more closely the higher the damping of the resonant system is, *i.e.*, the more the impressed oscillations preponderate over the natural oscillations. Accordingly, for *clear reproduction of speech it is better that the damping of the receiving antenna is not too low and that a closed (aperiodic) or, at any rate, highly damped detector circuit is coupled to the antenna.*

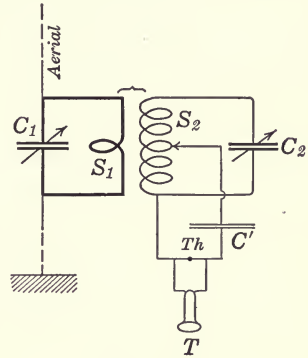

FIG. 455.

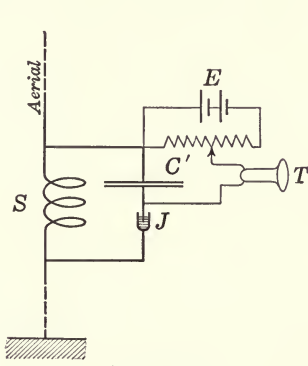

FIG. 456.

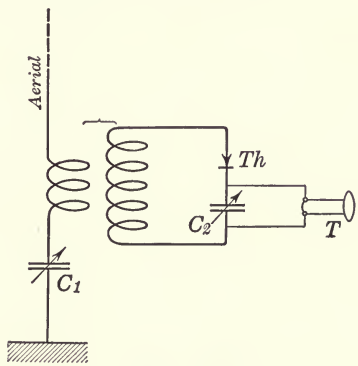

FIG. 457.

This idea was carried out in the arrangement (Fig. 456*) formerly used by the TELEFUNKEN Co. and also in that apparently now in use by POULSEN³²⁸ (Fig. 457). In the latter, however, an additional resonance circuit containing condenser C_2 is used, but this circuit must be very highly damped as detector Th is connected directly in circuit.

* C' is a block condenser.

b. In those methods in which the *frequency* instead of the amplitude of the transmitter oscillations is varied by the microphone, it is important that the receiver is not tuned exactly to the transmitter frequency.³³⁴ Otherwise, in view of the relatively flat peak of the resonance curve, the amplitude in the receiver would be only slightly changed (*A*) by a given change (*dN*, Fig. 458) in the frequency. But if the receiver is not quite

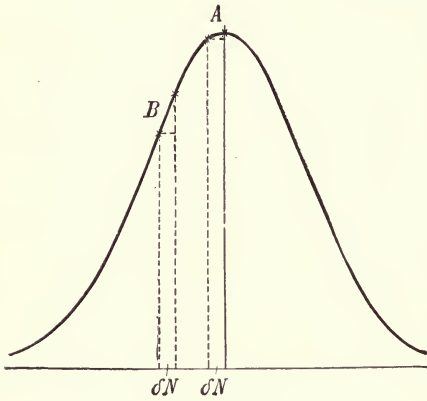

FIG. 458.

in tune with the transmitter, so that we are working on the rising or falling side of the resonance curve instead of at the peak, the same change, *dN*, in frequency causes a considerably greater change, *B*, in the amplitude.*

c. The *calling* of a desired radio-telephone station would also be made possible by the method described in Art. 169b. Another method which has been proposed,³³⁵ is to so adjust the receiving station for being called that the coupling between receiving antenna and

detector circuit is as close as possible and the normal telephone used for talking is replaced by a loud-speaking telephone.

212. The Action in the Detector Circuit.—*a.* If a *pure note or tone* is sung or played into the transmitting microphone, the amplitude of the wave which is radiated oscillates in the period of this note. The amplitude in the detector circuit must oscillate at the same frequency, so that its curve would be of the form of Fig. 459a.

Therefore, in the detector (which we may assume to be a thermal detector) there would be a corresponding e.m.f. with time variation as represented by Fig. 459b. It follows that the current obtained in the receiving telephone has the same periodicity as the rise and fall of the amplitude of the transmitter oscillations and therefore is of the same period as the tone impressed upon the microphone in the transmitter.

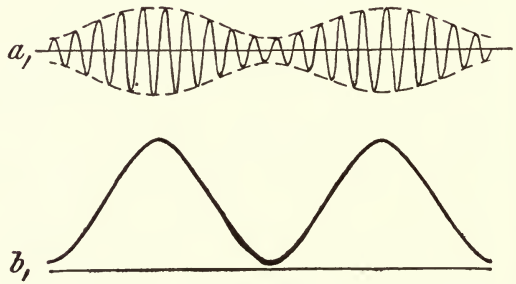

FIG. 459.

b. Similarly, if a *sound* other than a pure note, and consisting of a

* The same relation holds for wireless telegraphy in cases where the signals are produced by varying the frequency [Art. 127c].

fundamental and a large number of upper harmonics, is spoken into the microphone the same relation holds.

If, in this case, the telephone current is to accurately reproduce the amplitude fluctuations of the transmitter waves,* then, aside from the requirement discussed in Art. 211*a*, the detector must quantitatively follow the rapid amplitude fluctuations, *i.e.*, must develop direct-current energy approximately in proportion to the high frequency energy supplied to it. Hence thermal or crystal detectors† which fill this requirement are mostly used.

THE DEVELOPMENT OF WIRELESS TELEGRAPHY DURING THE YEARS 1909 TO 1912

a. Probably the most prominent feature in the development of wireless telegraphy during the last few years has been the general adoption of a *musical tone* in the receiving telephone.

Of the advantages thereby attainable, *viz.*,

1. Oral reception is made easier and more sensitive,
2. Greater freedom from atmospheric disturbances [Art. 183*b*],
3. The principle of acoustic resonance can be made use of [Arts. 166*b*, 167*d*, 169*b*],

4. Duplex reception with the same electric wave-length,³³⁶ the first two have certainly proven themselves to be very valuable. This accounts for the many different methods which have been devised for producing a tone in the telephone receiver.

A. The most obvious thing to do, which A. BLONDEL had suggested as early as 1900, was to give to the frequency of the desired tone to the wave at its point of origin, the *transmitter*—"tone transmitter."

A great number of methods for accomplishing this with *damped* waves have been proposed, thus:

1. For A.C. operation, the use of an A.C. generator of sufficiently high frequency [Art. 114] either alone or combined with a rotating spark gap [Art. 118].

2. For D.C. operation, control of the discharge frequency by means of a rotating spark gap with projecting electrodes [Art. 118*b*], or

3. Superimposing an alternating current obtained from an arc circuit upon a constant direct current, an arrangement which offers a particularly easy means of varying the tone [Art. 128].

4. The same advantage is secured by a new method devised by A.

* It is assumed that the amplitude fluctuations of the transmitter waves accurately reproduce the fluctuations impressed upon the microphone.

† MAJORANA³³¹ obtained good results with an iron pyrites—platinum detector and particularly with DE FOREST'S "audion," in the form shown in Fig. 342 having three electrodes.

MEISSNER (TELEFUNKEN Co.); in this a periodic *auxiliary discharge* causes the main discharge to occur periodically with the same frequency as the auxiliary discharge.³³⁷

Similarly a great number of methods for producing a tone transmitter have been devised for *undamped* oscillations.

1. It was proposed to break up the continuous oscillations of the antenna into a sequence of regular wave trains by means of an interrupter.³³⁸

2. To vary the amplitude of the radiated wave at the frequency of the desired tone by means of an arc circuit acting upon the high frequency generator.³³⁹

3. To produce *fluctuations* in the antenna, either by causing two arc generators slightly out of tune to act upon the antenna (C. LORENZ³⁴⁰) or, if a high frequency alternator is used, by means of special connections of the groups of coils in the windings of the machine (R. GOLDSCHMIDT³⁴¹).

B. But with undamped oscillations it is undoubtedly simpler to leave the amplitude of the radiated waves constant and to make provision for "*tone reception*" at the *receiving* end.

1. The first means which offers itself for this purpose is to periodically connect and disconnect the detector from the receiving circuits [Art. 187].

2. Then, it is also possible to obtain tone reception by combining with the oscillation induced in the receiver by the transmitted waves, another oscillation of somewhat different frequency [Art. 190].

Some of the methods mentioned above have probably never found practical application. If very fully listed here, it was with the idea of illustrating the great number of possible solutions for a given problem in this field of work—"solutions" at any rate in the patent papers.

b. With stations employing damped oscillations, whether the WIEN or the BRAUN type of transmitter is used, the essential requirement for tone transmission is a *discharge frequency* at least as high as the frequency of the desired tone, much higher therefore than was formerly customary. At the same energy and the same decrement such a transmitter has a much lower oscillation amplitude than the older transmitter of lower spark frequency, and therefore has a number of technical advantages over the latter [Art. 120*b* and *c*].

The good results obtained by raising the discharge frequency up to that of audible tones, suggested raising the frequency still higher and thus increasing the energy. When this was attempted, however, a limit to the frequency was very soon encountered. For, on one hand, the intensity of the tone in the receiving telephone soon fails to keep pace with the energy when the latter is increased in this way and, on the other hand, with the long waves used by high-power stations, the intervals between the individual wave trains disappear and the wave trains overlap and interfere with one another. Hence we have here again reached the point

where increasing the amplitude is the only path open to us, if damped oscillations are to be retained.

c. The alternative is to turn to *undamped* oscillations. And the fact is that undamped oscillations, particularly those produced by *high frequency alternators*, are coming to be very serious competitors in the field in which, until recent years, there were only three great rivals (the BRAUN, WIEN and POULSEN transmitters).

The adoption of high frequency machines has long been hampered by the technical difficulties to be overcome in building alternators of frequencies sufficiently high for the requirements of radio-telegraphy. It is comparatively simple to obtain frequencies ranging just below those needed. Hence the idea underlying recent developments in this direction has been *transformation of the frequency*. Only a moderately high alternator frequency, as determined by the number of poles and speed of the machine, is employed, but is then transformed to frequencies two, three or more times that of the original value.

R. GOLDSCHMIDT may be named as the first one to introduce this idea in radio-practice, if we conceive his method [Art. 122] as a frequency transformation *within* the alternator.

As early as 1898, a method of transforming the frequency of an alternating current *outside of the machine* to twice the original frequency by means of *rectifying cells* was proposed (J. ZENNECK³⁴²).

If an alternating current of the form of Fig. 460a is sent through a rectifying cell or tube, which allows current to pass through it in one direction only, the resultant current curve will be as shown in Fig. 460b. If the connections of the rectifier are reversed, the current curve will be as shown in Fig. 460c. If the two resultant currents (Fig. 460b and c)

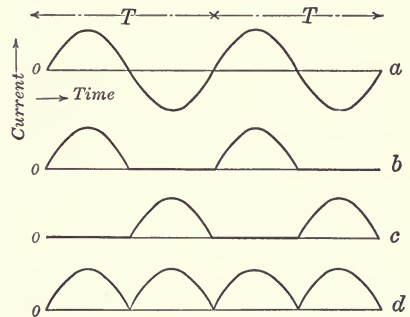

FIG. 460.

obtained in this manner are caused to act inductively upon a third circuit—preferably a condenser circuit tuned to twice the original frequency—a current of the form of Fig. 460d, having double the initial frequency, will be obtained in the third circuit. The e.m.f. induced in this resonant condenser circuit has of course double the frequency of the initial e.m.f. also.

Another method for doubling the frequency was first described by the LAHMEYER Co. (EPSTEIN³⁴³) and has been adapted for high frequency work by COUNT V. ARCO (TELEFUNKEN Co.³⁴⁴). This method is based upon the magnetic properties of iron.

The principle involved is as follows: Through one of two windings

on an iron transformer core, direct current is passed of such magnitude that the flux density in the iron—represented in Fig. 461*b* and *c* by the dotted lines—is just about at the knee of the magnetization curve. Then, if alternating current is sent through the other winding, it can produce only a slight increase in the flux density during the half periods in which its field has the same direction as the direct-current field; but in the other half periods when the alternating current is reversed, it

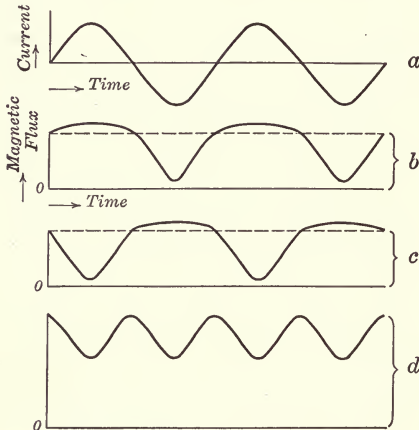

FIG. 461.

will greatly reduce the resultant flux density. The curve of the resultant magnetic flux must, therefore, have the form of Fig. 461*b*. By commutating the alternating current a flux curve of the form of Fig. 461*c* is obtained. If, now, two varying fluxes of the forms of Fig. 461*b* and *c* respectively are simultaneously caused to act inductively upon a conductive circuit—as before, preferably a condenser circuit tuned to the double frequency—the total resultant flux acting upon this circuit will be the algebraic sum of the two individual fluxes

and will have the form of Fig. 461*d*. This will, therefore, induce an e.m.f. of twice the original frequency in the condenser circuit.

A third method (J. ZENNECK³⁴⁵), by means of which the original frequency can be tripled, makes use of the strong third harmonic (second upper partial oscillation) which is characteristic of the potential across an alternating-current arc.

If a self-induction and capacity are connected across the poles of an A.C. arc, similarly to the THOMSON or POULSEN methods [Art. 123], a heavy current of three times the frequency of the supply current will be obtained in this parallel condenser circuit, if the capacity and self-induction values are properly chosen.

Of these three methods, only the second, as developed by COUNT V. ARCO (TELEFUNKEN Co.), appears to have been commercially applied to high frequency work. But even in regard to this method very little has been published as to the actual results obtained, other than that with an initial frequency of 7500 cycles per second ($\lambda = 40,000$ m.) the efficiency of one transformation is about 85 per cent. and that of two transformations (four times the initial frequency) is still 60 per cent.³⁴⁴

A conclusive opinion as to the value of these methods will not be possible until additional performance data are available and, more

particularly, until we know to what extent the *difficult problem of holding the speed of a high frequency alternator constant, has been solved.*

d. If the use of high frequency alternators in conjunction with one of these frequency transformation methods should prove to be a practical success, then this would at the same time be a great step forward for *directive signaling*, which has greatly increased in importance during the last few years. For with alternators it is much easier to produce a given phase difference between two high frequency currents—for instance by coupling two machines to each other or by having two armatures slightly displaced with respect to each other in the same machine—than with the earlier methods [Arts. 200 and 201] which moreover never seem to have found any practical application. But as soon as it becomes a relatively simple matter to generate high frequency currents having any desired phase difference, a means of building directive transmitters having much more advantageous distance effect characteristics than heretofore will be at hand.

e. Then, too, it will perhaps be more convenient to generate the *large quantities of energy* needed in modern high-power stations in alternators than with the older methods.

The *energy quantities* employed in radio-telegraphy have been greatly increased during recent years. Whereas only a few years ago, stations operating with 100 kw. were considered as something tremendous, it is reported that the MARCONI transatlantic stations are being equipped with 1100 hp., and the TELEFUNKEN Co. is building a 500 kva. high frequency alternator. If we compare these high powers with the extremely low amounts of energy supplied in the early days of wireless telegraphy from small storage batteries to operate an induction coil and then compare the ranges obtained at that time with those now attainable, it would seem, at first glance, as if the actual results obtained have not kept pace with the increased energy employed in spite of the many technical improvements in the art. There may, in fact, be some truth in this (see *g*), but the explanation lies partly in the fact that we now are more critical of range ratings than formerly and that our conception of range alway includes the idea of constant reliable operation. Then, too, it has been found that the decrease in amplitude of an advancing wave is more rapid even over sea water [Art. 146b] than was formerly believed to be the case, so that an increase in range necessitates a much greater increase in radiated energy than was expected.

f. The same tendency toward larger dimensions in the recent development of radio-telegraphic methods which manifested itself in increased energy also has led to increased *wave-lengths*. For high-power stations we have gradually reached 7000 m. waves, primarily, no doubt, because of the better daylight distance effect of the longer waves as compared to the shorter and, secondly, as the use of larger amounts of

energy, at any rate in the primary circuits of the transmitters is simpler with long than with short waves.

g. The effect of this general tendency upon the *antennæ* has likewise been a transition to ever-increasing dimensions [Art. 92c, 202]. When practical structural limits were reached, refuge was taken in coils inserted in the antenna to increase its self-induction or in the "fly-wheel" method of connection. This, however, greatly reduced the radiation resistance. While this is very advantageous for reception both in regard to effectiveness of the receiver [Art. 172] as well as in regard to the simplicity of the connections [Art. 176], it is correspondingly disadvantageous for the transmitter [Art. 99]. The efficiency is greatly reduced, only a very small part of the energy being radiated, in spite of all known methods for minimizing the antenna losses. *Marconi* seems to have drawn the right conclusions from these relations in that he has separated the transmitting and receiving antennæ in his transatlantic stations, using an antenna of low radiating power for reception and one of greater radiating power for transmission.

But the chief difficulty is encountered in the "antenna with high radiation resistance." Just how great this is in the bent *MARCONI* antenna, has not become known. In vertical antennæ, an increase in the radiation resistance is identical with an increase in the height of the antenna, the wave-length remaining the same; this correct but by no means simple method has been introduced by the *TELEFUNKEN* Co. in its great antenna (200 m. high) at Nauen.

h. The development of radio-telegraphy *as a whole* in recent years can undoubtedly be considered as very gratifying.³⁴⁶ The great importance of wireless telegraphy as a factor in the safety of ships and their passengers, has resulted in laws and regulations obligating the installation of radio-equipment on all ships above a certain size.

Furthermore, the field of application of wireless telegraphy has extended considerably. Whereas it formerly was used only for the transmission of ordinary telegrams, it now serves as a means for furnishing ships at sea with regular standard time signals³⁴⁷ and storm warnings,³⁴⁸ for the determination of geographic longitudes³⁴⁹ and also for the remote control of experimental recording balloons and similar meteorological purposes.^{350,*} Thus radio-telegraphy has already found a much more extensive application than one dared to hope for in the early years of its use.

*[Translator's Note.—Recent developments in connection with wireless signaling for railroad operation seem to indicate the opening of still another field.]

TABLES

Table I.—The Natural

$$N = \frac{1}{2\pi\sqrt{CL}} = \text{number of complete periods or cycles per second [Art. 3].}$$

In the following table the capacity is expressed in 1/1000 mf. = 10⁻¹⁸ c.g.s. units and the coefficient of self-induction in c.g.s. units. The figures given must be multiplied by 10⁶ to give the values of *N*.

The following examples illustrate how the table is used for values of *C* and *L* other than those given:

	1	1.1	1.2	1.3	1.4	1.5	2	2.5	3
100	15.9	15.2	14.5	14.0	13.4	13.0	11.3	10.1	9.19
110	15.2	14.5	13.9	13.3	12.4	12.4	10.7	9.60	8.76
120	14.5	13.9	13.3	12.7	12.3	11.9	10.3	9.19	8.39
130	14.0	13.3	12.7	12.2	11.8	11.4	9.87	8.83	8.64
140	13.4	12.8	12.3	11.8	11.4	11.0	9.51	8.51	7.77
150	13.0	12.4	11.9	11.4	11.0	10.6	9.19	8.22	7.50
200	11.3	10.7	10.3	9.87	9.51	9.19	7.96	7.12	6.50
250	10.1	9.60	9.19	8.83	8.51	8.22	7.12	6.37	5.81
310	9.19	8.76	8.39	8.64	7.77	7.50	6.50	5.81	5.30 ₅
350	8.51	8.11	7.77	7.46	7.19	6.95	6.01 ₅	5.38	4.91
400	7.96	7.59	7.26	6.98	6.72	6.50	5.63	5.03	4.59
450	7.50	7.15	6.85	6.58	6.34	6.13	5.30 ₅	4.74 ₅	4.33
500	7.12	6.79	6.50	6.24	6.01 ₅	5.81	5.03	4.50	4.11
600	6.50	6.20	5.93	5.70	5.49	5.30 ₅	4.59	4.11	3.75
700	6.02	5.74	5.49	5.28	5.08	4.91	4.25	3.80 ₅	3.47
800	5.63	5.37	5.14	4.93 ₅	4.76	4.59	3.98	3.56	3.25
900	5.31	5.06	4.84	4.65	4.48	4.33	3.75	3.35 ₅	3.06
1000	5.03	4.80	4.59	4.41	4.25	4.11	3.56	3.18	2.91
1100	4.80	4.56	4.38	4.21	4.06	3.92	3.39	3.03 ₅	2.77
1200	4.59	4.38	4.19	4.03	3.88	3.75	3.25	2.91	2.65
1300	4.41	4.21	4.03	3.87	3.73	3.60	3.12	2.79	2.55
1400	4.25	4.06	3.88	3.73	3.60	3.47	3.01	2.69	2.46
1500	4.11	3.92	3.75	3.60	3.47	3.35 ₅	2.91	2.60	2.37
2000	3.56	3.39	3.25	3.12	3.01	2.91	2.52	2.25	2.05 ₅
2500	3.18	3.03 ₅	2.91	2.79	2.69	2.60	2.25	2.01	1.84
3000	2.91	2.77	2.65	2.55	2.46	2.37	2.05 ₅	1.84	1.68
3500	2.69	2.56 ₅	2.46	2.36	2.27	2.20	1.90	1.70	1.55
4000	2.52	2.40	2.30	2.21	2.13	2.05 ₅	1.78	1.59	1.45
4500	2.37	2.26	2.17	2.08	2.00 ₅	1.94	1.68	1.50	1.37
5000	2.25	2.15	2.05	1.97	1.90	1.84	1.59	1.42	1.30
6000	2.05	1.96	1.88	1.80	1.74	1.68	1.45	1.30	1.19
7000	1.90	1.81	1.74	1.67	1.61	1.55	1.34	1.20	1.10
8000	1.78	1.70	1.61	1.56	1.50	1.45	1.26	1.12 ₅	1.03
9000	1.68	1.60	1.53	1.47	1.42	1.37	1.19	1.06	0.969

Coeff. of self-induction in c.g.s. units.

Frequency of Condenser Circuits³⁵¹

1. $C = 11 \times 10^{-8}$ mf.; $L = 800$ c.g.s.

$$\therefore N = \frac{1}{2\pi\sqrt{800 \times (11 \times 10^{-18})}} = \frac{1}{2\pi\sqrt{8000 \times 1.1 \times 10^{-18}}}$$

= 1.70×10^6 cycles per second.

2. $C = 0.45$ mf.; $L = 7000$ c.g.s.

$$\therefore N = \frac{1}{2\pi\sqrt{7000 \times (450 \times 10^{-18})}} = \frac{1}{2\pi \times 10\sqrt{7000 \times 4.5 \times 10^{-18}}}$$

= 0.897×10^6 cycles per second.

	3.5	4	4.5	5	6	7	8	9×10^{-3} mf.
	8.51	7.96	7.50	7.12	6.50	6.02	5.63	5.31
	8.11	7.59	7.15	6.79	6.20	5.74	5.37	5.06
	7.77	7.26	6.85	6.50	5.93	5.49	5.14	4.84
	7.46	6.98	6.58	6.24	5.70	5.28	4.93 ₅	4.65
	7.19	6.72	6.34	6.01 ₅	5.49	5.08	4.76	4.48
	6.95	6.50	6.13	5.81	5.30 ₅	4.91	4.59	4.33
	6.01 ₅	5.63	5.30 ₅	5.03	4.59	4.25	3.98	3.75
	5.38	5.03	4.74 ₅	4.50	4.11	3.80 ₅	3.56	3.35 ₅
	4.91	4.59	4.33	4.11	3.75	3.47	3.25	3.06
	4.55	4.25	4.01	3.80 ₅	3.47	3.21 ₅	3.01	2.84
	4.25	3.98	3.75	3.56	3.25	3.01	2.81	2.65
	4.01	3.75	3.54	3.35 ₅	3.06	2.84	2.65	2.50
	3.80 ₅	3.56	3.35 ₅	3.18	2.91	2.69	2.52	2.37
	3.47	3.25	3.06	2.91	2.65	2.46	2.30	2.17
	3.21 ₅	3.01	2.84	2.69	2.46	2.27	2.13	2.00 ₅
	3.01	2.81	2.65	2.52	2.30	2.13	1.99	1.88 ₅
	2.84	2.65	2.50	2.37	2.17	2.00 ₅	1.88	1.77
	2.69	2.52	2.37	2.25	2.05	1.90	1.78	1.68
	2.56 ₅	2.40	2.26	2.15	1.96	1.81	1.70	1.60
	2.46	2.30	2.17	2.05	1.88	1.74	1.62	1.53
	2.36	2.21	2.08	1.97	1.80	1.67	1.56	1.47
	2.27	2.13	2.00 ₅	1.90	1.74	1.61	1.50	1.42
	2.20	2.05 ₅	1.94	1.84	1.68	1.55	1.45	1.37
	1.90	1.78	1.68	1.59	1.45	1.34 ₅	1.26	1.19
	1.70	1.59	1.50	1.42	1.30	1.20	1.12 ₅	1.06
	1.55	1.45	1.37	1.30	1.19	1.10	1.03	0.969
	1.44	1.34 ₅	1.27	1.20	1.10	1.02	0.951	0.897
	1.34 ₅	1.26	1.19	1.12 ₅	1.03	0.951	0.890	0.839
	1.27	1.19	1.12	1.06	0.969	0.897	0.839	0.791
	1.20	1.12 ₅	1.06	1.01	0.919	0.851	0.796	0.750
	1.10	1.03	0.969	0.919	0.839	0.777	0.726	0.685
	1.02	0.951	0.897	0.851	0.777	0.719	0.673	0.634
	0.951	0.890	0.839	0.796	0.726	0.673	0.629	0.593
	0.897	0.839	0.791	0.750	0.685	0.634	0.593	0.572

Coeff. of self-induction in c.g.s. units.

Table II.—The Natural Wave-

$\lambda = 6\pi\sqrt{CL} \times 10^{10}\text{cm.} = 6\pi\sqrt{CL} \times 10^8\text{m.}$ [See second foot-note to Art. 3a].

In the following table the capacity is expressed in 1/1000 mf. = 10^{-18} c.g.s. units the coefficient of self-induction in c.g.s. units. The figures in the table give the wave-length in meters.

The following examples illustrate how the table can be used for values of C and L not given:

	1	1.1	1.2	1.3	1.4	1.5	2	2.5	3
100	18.8	19.8	20.6	21.5	22.3	23.1	26.7	29.8	32.6
110	19.8	20.7	21.7	22.5	23.4	24.2	28.0	31.3	34.2
120	20.6	21.7	22.6	23.5	24.4	25.3	29.2	32.6 ₅	35.8
130	21.5	22.5	23.5	24.5	25.4	26.3	30.4	34.0	37.2
140	22.3	23.4	24.4	25.4	26.4	27.3	31.5	35.3	38.6
150	23.1	24.2	25.3	26.3	27.3	28.3	32.6 ₅	36.5	40.0
200	26.7	28.0	29.2	30.4	31.5	32.6 ₅	37.7	42.1 ₅	46.2
250	29.8	31.3	32.6 ₅	34.0	35.3	36.5	42.1 ₅	47.1	51.6
300	32.6	34.2	35.8	37.2	38.6	40.0	46.2	51.6	56.0
350	35.3	37.0	38.6	40.2	41.7	43.2	49.9	55.8	61.1
400	37.7	39.5	41.3	43.0	44.6	46.2	53.3	59.6	65.3
450	40.0	41.9	43.8	45.6	47.3	49.0	56.5 ₅	64.4	69.3
500	42.1	44.2	46.2	48.1	49.9	51.6	59.6	66.6	73.0
600	46.2	48.4	50.6	52.6	54.6	56.5 ₅	65.3	73.0	80.0
700	49.9	52.3	54.6	56.9	59.0	61.1	70.5	78.8 ₅	86.4
800	53.3	55.9	58.4	60.8	63.1	65.3	75.4	84.3	92.3
900	56.5	59.3	61.9 ₅	64.5	66.9	69.3	80.0	89.4	97.9
1000	59.6	62.5	65.3	68.0	70.6	73.0	84.3	94.2	103
1100	62.5	65.6	68.5	71.3	74.0	76.6	88.4	98.8	108
1200	65.3	68.5	71.5	74.4 ₅	77.3	80.0	92.3	103	113
1300	68.0	71.3	74.4 ₅	77.5	80.4	83.2	96.1	107.5	118
1400	70.6	74.0	77.3	80.4	83.4 ₅	86.4	99.7	111.5	122
1500	73.0	76.6	80.0	83.2	86.4	89.4	103	115	126
2000	84.3	88.4	92.3	96.1	96.1	103	119	133	146
2500	94.2	98.8	103	107.5	111.5	115	133	149	163
3000	103	108	113	118	122	126	146	163	179
3500	112	117	122	127	132	137	158	176	193
4000	119	125	131	136	141	146	169	188.5	206.5
4500	126	133	138.5	144	150	155	179	200	219
5000	133	140	146	152	158	163	188.5	211	231
6000	146	153	160	166.5	173	179	206.5	231	253
7000	158	165	173	180	187	193	223	249	273
8000	169	177	185	192	199.5	206.5	238	267	292
9000	179	188	196	204	212	219	253	283	310

Coeff. of self-induction in c.g.s. units.

length of Condenser Circuits³⁵¹

1. $C = 11 \times 10^{-3}$ mf.; $L = 800$ c.g.s. units

$$\begin{aligned} \therefore \lambda &= 6\pi\sqrt{800 \times (11 \times 10^{-18})} \times 10^8 \\ &= 6\pi\sqrt{8000 \times 1.1 \times 10^{-18}} \times 10^8 = 177 \text{ m.} \end{aligned}$$

2. $C = 0.45$ mf.; $L = 7000$ c.g.s. units

$$\begin{aligned} \therefore \lambda &= 6\pi\sqrt{7000 \times (450 \times 10^{-18})} \times 10^8 \\ &= 10[6\pi\sqrt{7000 \times 4.5 \times 10^{-18}} \times 10^8] = 3345 \text{ m.} \end{aligned}$$

3.5	4	4.5	5	6	7	8	9 × 10 ⁻³ mf.
35.3	37.7	40.0	42.1	46.2	49.9	53.3	56.5
37.0	39.5	41.9	44.2	48.4	52.3	55.9	59.3
38.6	41.3	43.8	46.2	50.6	54.6	58.4	61.9 ₅
40.2	43.0	45.6	48.1	52.6	56.9	60.8	64.5
41.7	44.6	47.3	49.9	54.6	59.0	63.1	66.9
43.2	46.2	49.0	51.6	56.5 ₅	61.1	65.3	69.3
49.9	53.3	56.5 ₅	59.6	65.3	70.5	75.4	80.0
55.8	59.6	64.4	66.6	73.0	78.8 ₅	84.3	89.4
61.1	65.3	69.3	73.0	80.0	86.4	92.3	97.9
66.0	70.5	74.8	78.8 ₅	86.4	93.3	99.7	106
70.5	75.4	80.0	84.3	92.3	99.7	107	113
74.8	80.0	84.8	89.4	97.9	106	113	120
78.8 ₅	84.3	89.4	94.2 ₅	103	111 ₅	119	126
86.4	92.3	97.9	103	113	122	131	138 ₅
93.3	99.7	106	111 ₅	122	132	141	150
99.7	107	113	119	131	141	151	160
106	113	120	126	138 ₅	150	160	170
112	119	126	133	146	158	169	179
117	125	133	140	153	165	177	188
122	131	138 ₅	146	160	173	185	196
127	136	144	152	166 ₅	180	192	204
132	141	150	158	173	187	199 ₅	212
137	146	155	163	179	193	206 ₅	219
158	169	179	188 ₅	206 ₅	223	238	253
176	188 ₅	200	211	231	249	267	283
193	206 ₅	219	231	253	273	292	310
209	223	237	249	273	295	315	334 ₅
223	238	253	267	292	315	337	358
237	253	268	283	310	334 ₅	358	379
249	267	283	298	326 ₅	353	377	400
273	292	310	326 ₅	358	386	415	438
295	315	334 ₅	353	386	417	446	473
315	337	358	377	415	446	477	506
334 ₅	358	379	400	438	473	506	536 ₅

Table III.—Frequency and Wave-length

$$N = \frac{3 \times 10^{10} \text{ (cm. per sec.)}}{\lambda \text{ (cm.)}} = \frac{3 \times 10^8 \text{ (meters per sec.)}}{\lambda \text{ (meters)}} \quad [\text{Art. 19b}]$$

λ in m.	N	λ in m.	N	λ in m.	N	λ in m.	N
100	$3.00 \times 10^6/\text{sec.}$	510	$5.88 \times 10^5/\text{sec.}$	910	$3.29 \times 10^5/\text{sec.}$	2500	$1.18 \times 10^5/\text{sec.}$
110	2.73 "	520	5.77 "	920	3.26 "	2600	1.15 "
120	2.50 "	530	5.66 "	930	3.23 "	2650	1.13 "
130	2.31 "	540	5.56 "	940	3.19 "	2700	1.11 "
140	2.14 "	550	5.45 "	950	3.16 "	2750	1.09 "
150	2.00 "						
160	1.88 "	560	5.36 "	960	3.13 "	2800	1.07 "
170	1.76 "	570	5.26 "	970	3.09 "	2850	1.05 "
180	1.67 "	580	5.17 "	980	3.06 "	2900	1.03 "
190	1.58 "	590	5.08 "	990	3.03 "	2950	1.02 "
200	1.50 "	600	5.00 "	1000	3.00 "	3000	1.00 "
210	1.43 "	610	4.92 "	1050	2.86 "	3050	$9.84 \times 10^4/\text{sec.}$
220	1.36 "	620	4.84 "	1100	2.73 "	3100	9.67 "
230	1.31 "	630	4.76 "	1150	2.61 "	3150	9.53 "
240	1.25 "	640	4.69 "	1200	2.50 "	3200	9.38 "
250	1.20 "	650	4.62 "	1250	2.40 "	3250	9.23 "
260	1.15 "	660	4.55 "	1300	2.31 "	3300	9.09 "
270	1.11 "	670	4.47 "	1350	2.22 "	3350	8.96 "
280	1.07 "	680	4.41 "	1400	2.14 "	3400	8.82 "
290	1.03 "	690	4.35 "	1450	2.07 "	3450	8.69 "
300	1.00 "	700	4.29 "	1500	2.00 "	3500	8.57 "
310	$9.67 \times 10^5/\text{sec.}$	710	4.23 "	1550	1.94 "	3550	8.45 "
320	9.38 "	720	4.17 "	1600	1.88 "	3600	8.33 "
330	9.09 "	730	4.11 "	1650	1.82 "	3650	8.22 "
340	8.82 "	740	4.05 "	1700	1.76 "	3700	8.11 "
350	8.57 "	750	4.00 "	1750	1.71 "	3750	8.00 "
360	8.33 "	760	3.95 "	1800	1.67 "	3800	7.89 "
370	8.11 "	770	3.91 "	1850	1.62 "	3850	7.79 "
380	7.89 "	780	3.85 "	1900	1.58 "	3900	7.69 "
390	7.69 "	790	3.79 "	1950	1.54 "	3950	7.59 "
400	7.50 "	800	3.75 "	2000	1.50 "	4000	7.50 "
410	7.32 "	810	3.71 "	2050	1.46 "	4100	7.32 "
420	7.14 "	820	3.66 "	2100	1.43 "	4200	7.14 "
430	6.98 "	830	3.62 "	2150	1.40 "	4300	6.98 "
440	6.82 "	840	3.57 "	2200	1.36 "	4400	6.82 "
450	6.67 "	850	3.53 "	2250	1.33 "	4500	6.67 "
460	6.52 "	860	3.49 "	2300	1.31 "	4600	6.52 "
470	6.38 "	870	3.45 "	2350	1.28 "	4700	6.38 "
480	6.25 "	880	3.41 "	2400	1.25 "	4800	6.25 "
490	6.12 "	890	3.37 "	2450	1.22 "	4900	6.12 "
500	6.00 "	900	3.33 "	2500	1.20 "	5000	6.00 "

Table IV.—Oscillation Curves for Various Decrements

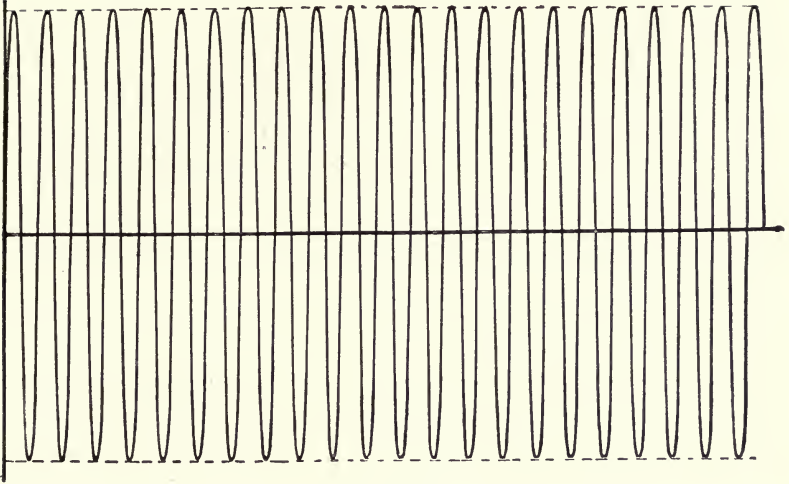

FIG. 462.

 $d = 0$, Undamped oscillations.

FIG. 463.

 $d = 0.003$.

Table IV. (Continued)

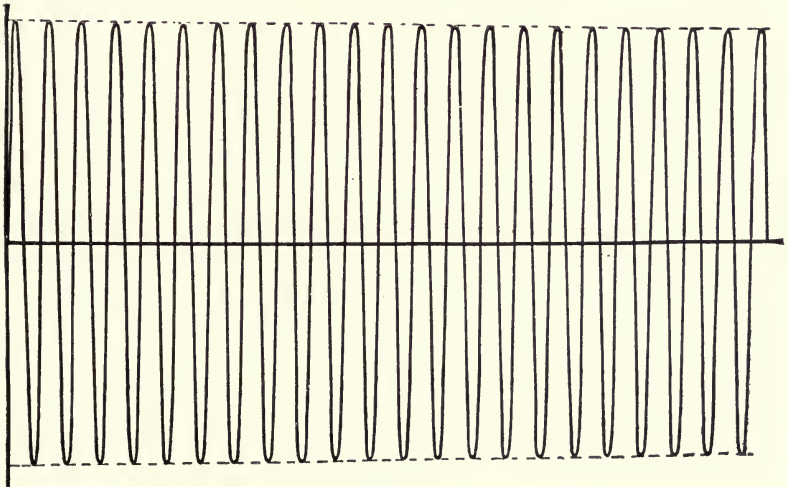
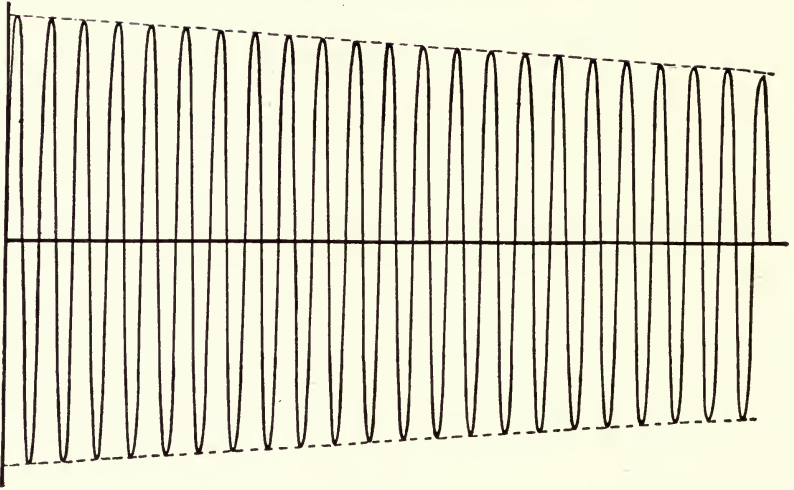

FIG. 464.

$$d = 0.01.$$

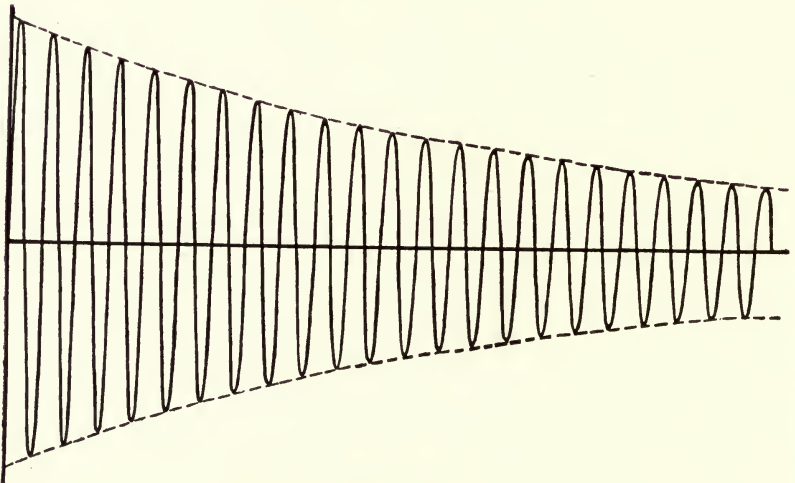

FIG. 465.

$$d = 0.06.$$

Table IV. (Continued)

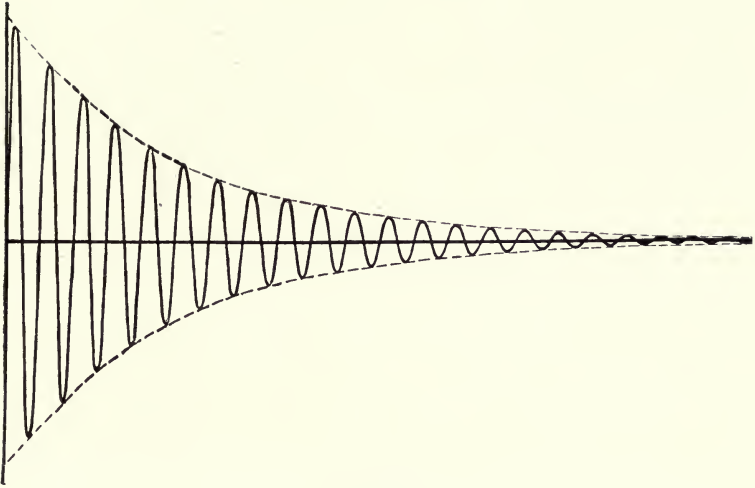

FIG. 466.
 $d = 0.2.$

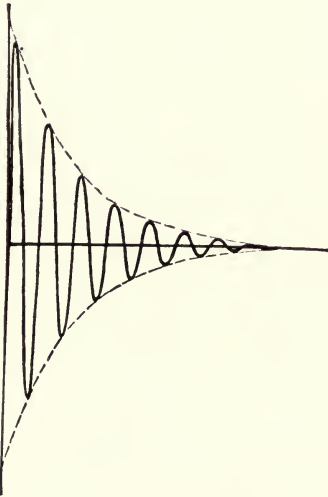

FIG. 467.
 $d = 0.5.$

Table V. The Spark (Arc) Constants³⁵²

According to Arts. 9*b* and 129*b*, the voltage, V , across the poles of a spark gap (or arc) can be expressed in terms of the current, I , flowing through the gap as follows:

$$V = a + \frac{b}{I} \quad (1)$$

The values of the constants of the spark gap or arc, a and b , depend upon the distance between the electrodes, their material and their condition and the gas in the gap.

The relation to the gap length, f , is approximately of the form

$$\left. \begin{aligned} a &= a_0 + a_1 f \\ b &= b_0 + b_1 f \end{aligned} \right\} \quad (2)$$

1. Thus for *direct-current* arcs in air the following figures have been determined: Electrodes of homogeneous carbon:

$$\left. \begin{aligned} a &= 38.88 + 2.074f^* \text{ volts} \\ b &= 11.66 + 10.54f \text{ watts} \end{aligned} \right\} \text{H. AYRTON}^{352}$$

Electrodes of copper

$$\left. \begin{aligned} a &= 21.38 + 3.03f \text{ volts} \\ b &= 10.69 + 15.24f \text{ watts} \end{aligned} \right\} \text{GUYE and ZÉBRIKOFF}^{352}$$

2. For *alternating-current* arcs, equations (1) and (2) also hold true approximately if V and I are taken to represent the *effective* voltage and current values. From observations made by HEUBACH³⁵² with carbon electrodes in air (current 4.4 and 6.5 amperes, $N = 50$ cycles per sec.), the following equations were obtained:

$$\left. \begin{aligned} a &= 23.4 + 1.21f^* \text{ volts} \\ b &= -13.8 + 3.71f \text{ watts} \end{aligned} \right\}$$

3. With damped *high frequency currents* ($\lambda = 2500$ m., $C = 2 \times 10^{-3}$, and 1×10^{-3} mf. and $L = 714 \times 10^3$, and 1480×10^3 c.g.s. units respectively), measurements made by D. ROSCHANSKY² led to the following expression for the initial amplitude, V_{f_0} , of the spark voltage:

$$V_{f_0} = a_0 + a_1 f \dagger$$

the values found for different electrodes being:

	Magnesium	Zinc	Copper	Silver
$a_0 =$	34.0	30.0	28.0	42.0 volts
$a_1 =$	7.6	10.4	10.9	10.4 volts

* f is in millimeters.

† f is in millimeters.

Table VI.—Equations for Calculation of the Coefficient of Self-Induction³⁵³

In the following equations ρ denotes the radius of the wire, r the radius of a turn, l the length of the coil (including the insulation on the end turns), n the total number of turns, n_1 the number of turns per centimeter and g the pitch of the winding, *i.e.*, the distance between the axial centers of two consecutive turns. If the lengths are expressed in centimeters, the equations give the coefficient of self-induction in c.g.s. units.

1. *Wire Loop.*

$$L_s = 4\pi r \left(\log_e \frac{8r}{\rho} - 1.75 \right) \text{ (KIRCHHOFF)}$$

$$L^* = 4\pi r \left(\log_e \frac{8r}{\rho} - 2 \right)$$

2. *Cylindrical coil with a single layer of only a few turns (B. STRASSER³⁵³):*

$$L_s = 4\pi r \left[n \left(\log_e \frac{8r}{\rho} - 1.75 \right) + n(n-1) \left(\log_e \frac{8r}{g} - 2 \right) - A \right. \\ \left. + \frac{g^2}{8r^2} \left\{ \left(3 \log_e \frac{8r}{g} - 1 \right) \left(\frac{n^2(n-1)}{12} \right) - B \right\} \right]$$

The values of A and B are given in the table which follows.

3. *Cylindrical coil whose length is great in comparison to its diameter. For this,*

$$L \text{ or } L_s = 4\pi^2 r^2 n_1^2 l$$

is a very rough approximation.

4. *Cylindrical coil with a single layer of turns whose diameter is large in comparison to the length of the coil (LORD RAYLEIGH).*

$$L_s = 4\pi r n^2 \left\{ \log_e \frac{8r}{l} - \frac{1}{2} + \frac{l^2}{32r^2} \left(\log_e \frac{8r}{l} + \frac{1}{4} \right) \right\} - \Delta L_s$$

The following equation (COFFIN³⁵³) holds almost exactly for coils of only one layer of turns whose radius is equal to the coil length and is approximately true without great error even if the coils are somewhat longer.

$$L_s = 4\pi r n^2 \left\{ \log_e \frac{8r}{l} - \frac{1}{2} + \frac{l^2}{32r^2} \left(\log_e \frac{8r}{l} + \frac{1}{4} \right) - \frac{1}{1024} \frac{l^4}{r^4} \left(\log_e \frac{8r}{l} - \frac{2}{3} \right) \right. \\ \left. + \frac{10}{131072} \times \frac{l^6}{r^6} \left(\log_e \frac{8r}{l} - \frac{109}{120} \right) - \frac{35}{4194304} \frac{l^8}{r^8} \left(\log_e \frac{8r}{l} - \frac{431}{420} \right) \right\} - \Delta L_s$$

In these equations the correction factor $\Delta L_s = 4\pi r n (C + D)$ (E. B. ROSA³⁵³). The values of C and D are given in the table following below.

5. *Flat spiral, in which the product $ng \leq 0.5r$ (r is here the radius of the middle turn, *i.e.*, the mean radius) (A. ESAU³⁵³).*

$$L_s = 4\pi r \left\{ n \left(\log_e \frac{r}{\rho} + 0.333 \right) + n(n-1) \left(\log_e \frac{8r}{g} - 2 \right) - A + \frac{g^2}{8r^2} \right. \\ \left. \left[\left(\log_e \frac{8r}{g} + 3 \right) \left(\frac{n^2(n^2-1)}{12} \right) - \frac{B}{3} \right] \right\} \text{ c g.s. units}$$

6. *Rectangle whose sides are a and b , of wire whose radius is ρ :*

$$L_s = 4 \left\{ a \log_e \frac{2ab}{r(a + \sqrt{a^2 + b^2})} + b \log_e \frac{2ab}{r(b + \sqrt{a^2 + b^2})} \right. \\ \left. + 2(\sqrt{a^2 + b^2} - a - b) \right\} \text{ c.g.s. units}$$

* L = effective coefficient of self-induction, calculated under the assumption that the current flows only through a very thin surface sheath or "skin."

Table for A and B

<i>n</i>	<i>A</i>	<i>B</i>	<i>n</i>	<i>A</i>	<i>B</i>
1	16	354.4	35,694
2	17	415.8	46,757
3	1.386	8.315	18	482.8	60,427
4	4.970	43.296	19	555.5	76,662
5	11.33	140.82	20	634.2	96,910
6	20.90	366.95	21	718.9	119,330
7	34.06	794.73	22	809.7	146,517
8	51.11	1,499.55	23	906.6	178,140
9	72.32	2,590.62	24	1,009.8	217,338
10	97.92	4,187.55	25	1,119.4	259,868
11	128.17	6,572.94	26	1,235.4	305,044
12	163.14	9,769.47	27	1,357.9	359,767
13	202.1	14,042.1	28	1,487.1	421,783
14	248.2	19,532.2	29	1,618.1	491,819
15	298.6	26,740.1	30	1,765.4	570,515

Table for C

$\frac{2\rho}{g}$	<i>C</i>	$\frac{2\rho}{g}$	<i>C</i>	$\frac{2\rho}{g}$	<i>C</i>
1.00	0.5568	0.79	0.3211	0.59	0.0292
0.99	0.5468	0.78	0.3084	0.58	0.0121
0.98	0.5367	0.77	0.2955	0.57	-0.0053
0.97	0.5264	0.76	0.2824	0.56	-0.0230
0.96	0.5160	0.75	0.2691	0.55	-0.0410
0.95	0.5055	0.74	0.2557	0.54	-0.0594
0.94	0.4949	0.73	0.2421	0.53	-0.0781
0.93	0.4842	0.72	0.2283	0.52	-0.0971
0.92	0.4734	0.71	0.2143	0.51	-0.1165
0.91	0.4625	0.70	0.2001	0.50	-0.1363
0.90	0.4515	0.69	0.1857	0.45	-0.2416
0.89	0.4403	0.68	0.1711	0.40	-0.3594
0.88	0.4290	0.67	0.1563	0.35	-0.4928
0.87	0.4176	0.66	0.1413	0.30	-0.6471
0.86	0.4060	0.65	0.1261	0.25	-0.8294
0.85	0.3943	0.64	0.1106	0.20	-1.0526
0.84	0.3825	0.63	0.0949	0.15	-1.3403
0.83	0.3705	0.62	0.0789	0.10	-1.7457
0.82	0.3584	0.61	0.0626		
0.81	0.3461	0.60	0.0460		
0.80	0.3337				

Table for D

<i>n</i>	<i>D</i>	<i>n</i>	<i>D</i>	<i>n</i>	<i>D</i>
1	0.0000	35	0.3119	300	0.3343
2	0.1137	40	0.3148	400	0.3351
3	0.1663	45	0.3169	500	0.3356
4	0.1973	50	0.3186	600	0.3359
5	0.2180				
		60	0.3216	700	0.3361
6	0.2329	70	0.3239	800	0.3363
7	0.2443	80	0.3257	900	0.3364
8	0.2532	90	0.3270	1000	0.3365
9	0.2604	100	0.3280		
10	0.2664				
		125	0.3298		
15	0.2857	150	0.3311		
20	0.2974	175	0.3321		
25	0.3042	200	0.3328		
30	0.3083				

Table VII.—Effective

The figures give the resistance of 1 m. in ohms, under the assumption
are correct within

Diam. of wire in mm.	“Station- ary” current	$N = 5 \times 10^4$ cyc./sec. $\lambda = 6000$ m.	$N = 1 \times 10^5$ cyc./sec. $\lambda = 3000$ m.	$N = 1.5 \times 10^5$ cyc./sec. $\lambda = 2000$ m.	$N = 2 \times 10^5$ cyc./sec. $\lambda = 1500$ m.	$N = 2.5 \times 10^5$ cyc./sec. $\lambda = 1200$ m.	$N = 3 \times 10^5$ cyc./sec. $\lambda = 1000$ m.
0.2	0.554	0.55	0.56	0.56	0.56	0.56	0.56
0.4	0.138	0.139	0.141	0.143	0.148	0.152	0.157
0.6	0.0615	0.063	0.067	0.072	0.078	0.086	0.093
0.8	0.0346	0.0370	0.0422	0.0498	0.056	0.062	0.067
1	0.0221	0.0254	0.0323	0.0382	0.0434	0.0480	0.052
1.2	0.0154	0.0196	0.0262	0.0314	0.0354	0.0393	0.0427
1.4	0.0113	0.0164	0.0221	0.0263	0.0298	0.0331	0.0359
1.6	0.00865	0.0140	0.0189	0.0226	0.0258	0.0285	0.0311
1.8	0.00683	0.0123	0.0169	0.0199	0.0226	0.0251	0.0273
2	0.00554	0.0110	0.0148	0.0178	0.0202	0.0225	0.0245
2.2	0.00457	0.0098	0.0133	0.0159	0.0182	0.0203	0.0221
2.4	0.00384	0.0089	0.0121	0.0146	0.0166	0.0185	0.0202
2.6	0.00328	0.0081	0.0111	0.0134	0.0153	0.0171	0.0186
2.8	0.00282	0.0075	0.0102	0.0123	0.0141	0.0158	0.0172
3	0.00246	0.0069	0.0095	0.0115	0.0132	0.0147	0.0160
3.2	0.00216	0.0065	0.0089	0.0107	0.0123	0.0137	0.0149
3.4	0.00192	0.0061	0.0083	0.0101	0.0116	0.0129	0.0141
3.6	0.00171	0.0057	0.0079	0.0096	0.0110	0.0122	0.0133
3.8	0.00153	0.0053 ₅	0.0074	0.0090	0.0103	0.0114	0.0125
4	0.00138	0.0051	0.0070	0.0085	0.0097	0.0108	0.0118
4.2	0.00125	0.00479	0.0066	0.0080	0.0092	0.0103	0.0112
4.4	0.00114	0.00456	0.0063	0.0077	0.0088	0.0098	0.0107
4.6	0.00105	0.00438	0.0061	0.0074	0.0085	0.0094	0.0103
4.8	0.000961	0.00417	0.0058	0.0070	0.0081	0.0090	0.0096
5	0.000886	0.00400	0.0055 ₅	0.0067	0.0077	0.0086	0.0094
5.2	0.000819	0.00383	0.0053	0.0065	0.0074	0.0083	0.0090 ₅
5.4	0.000759	0.00368	0.0051	0.0062	0.0071 ₅	0.0080	0.0086
5.6	0.000706	0.00354	0.00493	0.0060	0.0069	0.0076	0.0083
5.8	0.000658	0.00341	0.0047 ₅	0.0058	0.0066 ₅	0.0074	0.0081
6	0.000615	0.00330	0.00458	0.0056	0.0064	0.0071	0.0078
6.2	0.000576	0.00319	0.00443	0.0054	0.0062	0.0069	0.0075 ₅
6.4	0.000541	0.00309	0.00429	0.0052	0.0060	0.0067	0.0073
6.6	0.000508	0.00299	0.00415	0.0050 ₅	0.0058	0.0064 ₅	0.0071
6.8	0.000479	0.00290	0.00403	0.00489	0.0056	0.0063	0.0068 ₅
7	0.000452	0.00281	0.00391	0.00475	0.0055	0.0061	0.0067
7.2	0.000427	0.00272	0.00379	0.00461	0.0053	0.0059	0.0064 ₅
7.4	0.000404	0.00265	0.00369	0.00448	0.0051	0.0058	0.0063
7.6	0.000383	0.00257	0.00359	0.00433	0.0050	0.0056	0.0061
7.8	0.000364	0.00251	0.00350	0.00426	0.00488	0.0055	0.0059
8	0.000346	0.00244	0.00341	0.00415	0.00477	0.0053	0.0058

Resistance of Copper Wires³⁵⁴

that the specific conductivity $\sigma = 57.5 \times 10^{-5}$ c.g.s. units. The figures
1 to 2 per cent.

$N = 3.5 \times 10^5$ cyc./sec. $\lambda = 857$ m.	$N = 4 \times 10^5$ cyc./sec. $\lambda = 750$ m.	$N = 4.5 \times 10^5$ cyc./sec. $\lambda = 667$ m.	$N = 5 \times 10^5$ cyc./sec. $\lambda = 600$ m.	$N = 10^6$ cyc./sec. $\lambda = 300$ m.	$N = 1.5 \times 10^6$ cyc./sec. $\lambda = 200$ m.	$N = 2 \times 10^6$ cyc./sec. $\lambda = 150$ m.	$N = 3 \times 10^6$ cyc./sec. $\lambda = 100$ m.
0.56	0.56	0.56 ₅	0.57	0.61	0.66	0.73	0.86
0.163	0.168	0.175	0.183	0.245	0.293	0.328	0.399
0.099	0.104	0.110	0.115	0.156	0.187	0.213	0.257
0.072	0.076	0.079	0.083	0.110	0.136	0.157	0.190
0.055 ₅	0.062	0.065	0.069	0.108	0.124	0.138	0.151
0.0456	0.0489	0.051	0.053	0.074	0.089	0.103	0.125
0.0384	0.0405	0.0452	0.0450	0.062	0.076	0.087	0.106
0.0333	0.0353	0.0372	0.0394	0.054	0.066	0.076	0.093
0.0294	0.0314	0.0331	0.0345	0.0480	0.058	0.067	0.083
0.0263	0.0278	0.0295	0.0310	0.0432	0.053	0.061	0.074
0.0238	0.0254	0.0267	0.0280	0.0392	0.0479	0.0551	0.067
0.0217	0.0231	0.0243	0.0243	0.0357	0.0438	0.0506	0.062
0.0200	0.0212	0.0224	0.0236	0.0329	0.0400	0.0469	0.057
0.0185	0.0196	0.0207	0.0223	0.0307	0.0379	0.0433	0.053
0.0172	0.0183	0.0193	0.0204	0.0287	0.0350	0.0405	0.049 ₇
0.0161	0.0171	0.0180	0.0190	0.0267	0.0328	0.0381	0.0459
0.0151	0.0160	0.0170	0.0178	0.0252	0.0309	0.0357	0.0431
0.0143	0.0154	0.0160	0.0168	0.0239	0.0293	0.0337	0.0407
0.0134	0.0143	0.0151	0.0159	0.0225	0.0277	0.0314	0.0386
0.0127	0.0136	0.0140	0.0151	0.0214	0.0263	0.0300	0.0366
0.0121	0.0128	0.0136	0.0145	0.0205	0.0246	0.0285	0.0349
0.0115	0.0123	0.0130	0.0138	0.0196	0.0235	0.0272	0.0331
0.0111	0.0118	0.0125	0.0131	0.0187	0.0225	0.0260	0.0317
0.0106	0.0113	0.0120	0.0127	0.0177	0.0216	0.0250	0.0304
0.0101	0.0108	0.0115	0.0124	0.0169	0.0207	0.0240	0.0292
0.0097 ₅	0.0104	0.0111	0.0116	0.0162	0.0199	0.0229	0.0281
0.0093	0.0100	0.0106	0.0112	0.0156	0.0192	0.0220	0.0271
0.0091	0.0097	0.0102	0.0108	0.0152	0.0185	0.0213	0.0261
0.0087	0.0093	0.0099	0.0104	0.0146	0.0176	0.0203	0.0252
0.0084	0.0090	0.0095	0.0101	0.0141	0.0172	0.0199	0.0243
0.0081	0.0087	0.0092	0.0098	0.0136	0.0167	0.0192	0.0235
0.0079	0.0084	0.0089	0.0095	0.0132	0.0162	0.0186	0.0228
0.0076	0.0081	0.0086	0.0092	0.0128	0.0157	0.0181	0.0221
0.0074	0.0078	0.0083	0.0088	0.0123	0.0151	0.0175	0.0214
0.0071	0.0076	0.0081	0.0085	0.0120	0.0148	0.0172	0.0208
0.0070	0.0074	0.0079	0.0083	0.0117	0.0143	0.0166	0.0203
0.0067 ₅	0.0072	0.0077	0.0081	0.0114	0.0139	0.0160	0.0196
0.0066	0.0071	0.0075	0.0079	0.0111	0.0135	0.0156	0.0192
0.0064	0.0069	0.0073	0.0077	0.0108	0.0132	0.0152	0.0186
0.0063	0.0067	0.0071	0.0075	0.0105	0.0129	0.0148	0.0182

Table VIII.—Maximum Diameter of Resistance Waves³⁵⁵

At the diameters given in the table (in millimeters) the resistance differs by 1 per cent. from the D.C. resistance. If the difference is required to be within 0.1 per cent., the wire diameter must not be more than about half (0.56, to be exact) the value given in the table. A wire of twice the diameter in the table (or rather, 1.78 times the diameter) involves a 10 per cent. difference.

Material	Conductivity in c.g.s. units	Maximum diameter in millimeters			
		$N = 5 \times 10^4$ cyc./sec. $\lambda = 6000$ m.	$N = 2.5 \times 10^5$ cyc./sec. $\lambda = 1200$ m.	$N = 5 \times 10^5$ cyc./sec. $\lambda = 600$ m.	$N = 2.5 \times 10^6$ cyc./sec. $\lambda = 120$ m.
Iron:					
Permeability 3000.....	10×10^{-5}	0.019	0.0084	0.0060	0.0027
1000.....	10×10^{-5}	0.033	0.015	0.010	0.0046
300.....	10×10^{-5}	0.059	0.027	0.018	0.0084
100.....	10×10^{-5}	0.099	0.044	0.031	0.014
10.....	10×10^{-5}	0.33	0.15	0.10	0.046
Gold.....	45×10^{-5}	0.56	0.25	0.17	0.079
Copper.....	57.5×10^{-5}	0.49	0.22	0.15	0.0069
Konstantan.....	2×10^{-5}	2.6	1.2	0.83	0.37
Manganin }.....	2.4×10^{-5}	2.4	1.1	0.75	0.34
Nickelin }					
Platinum.....	10×10^{-5}	1.2	0.57	0.37	0.17
Graphite*.....	0.08×10^{-5}	13.2	5.9	4.2	1.9
	to				
	0.4×10^{-5}	5.9	2.7	1.9	0.84
Carbon (arc-lamp).....	0.025×10^{-5}	23.6	10.6	7.5	3.4
Mercury.....	1.06×10^{-5}	3.6	1.6	1.1	0.51
Concentrated CuSO_4 solu- tion.....	4.6×10^{-11}	175	78	55	25

* For a rectangular section, the figures give, with close approximation, the maximum value which the largest diameter may have, if the difference between effective and D.C. resistance is to be not greater than 1 per cent.

Table IX.—Gap Lengths and Corresponding Minimum Discharge Voltages⁶⁴

For short gaps:

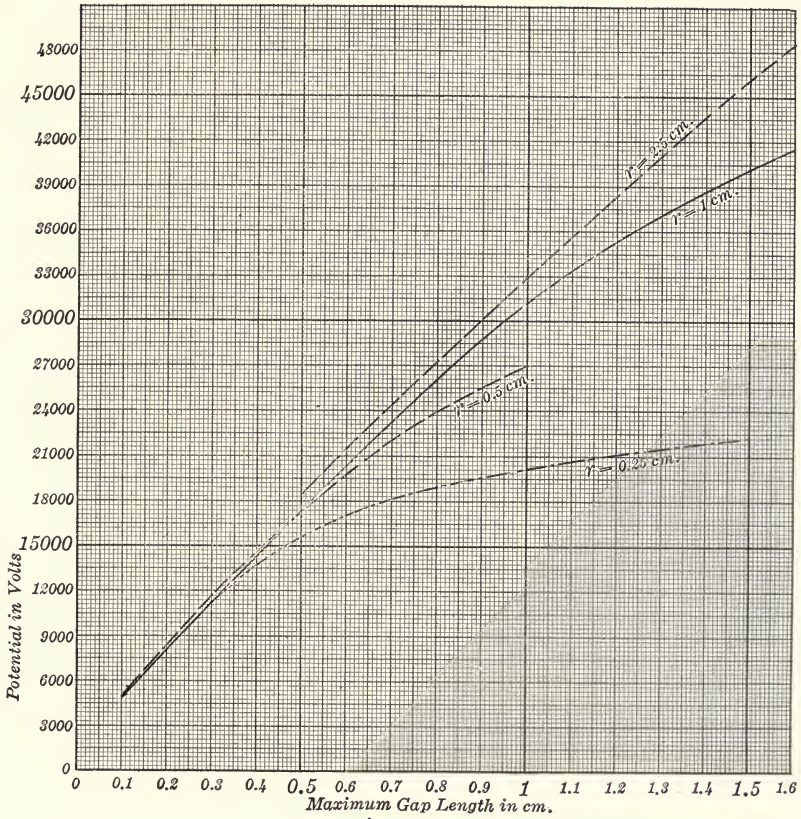

FIG. 46S.

For longer gaps:

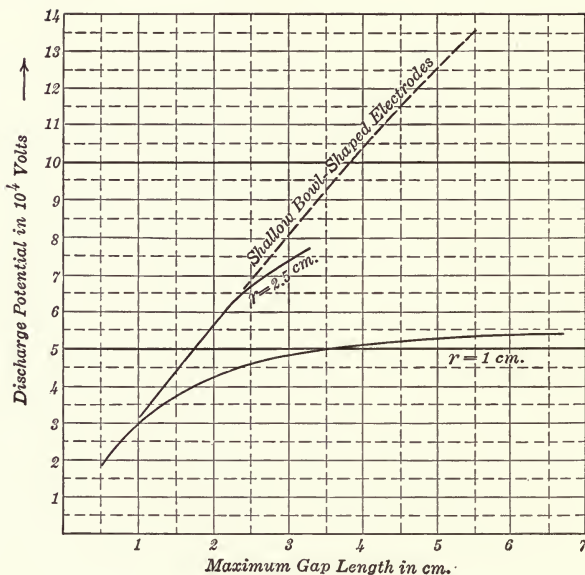

FIG. 469.

In these figures (468 and 469), r is the radius of the spherical electrodes; the dotted curve in Fig. 469 refers to very shallow bowl-shaped electrodes.

The values plotted are the *normal discharge* or *ignition voltages*, *i.e.*, the voltages which are just sufficient for the discharge to take place in air having no appreciable ionization.

The values of Fig. 468 are due to A. HEYDWEILLER,⁶⁴ those of Fig. 469 to C. MÜLLER⁶⁶ (for the short gap lengths) and E. HUPKA⁶⁴ and those for the dotted curve in Fig. 469 are due to W. WEICKER;⁶⁴ barometric pressure 745 mm., temperature about 18° C. The figures for Fig. 468 were determined in dry air at 18° C. temperature and 745 mm. pressure; an increase of 8 mm. pressure and a decrease of 3° temperature cause an increase of 1 per cent. in the voltages.

Table X.—Determination of Percentage Coupling

According to Art. 87, the degree of coupling is

$$K' = 1 - \left(\frac{N}{N^I}\right)^2 = \left(\frac{N}{N^{II}}\right)^2 - 1 = \frac{1 - \left(\frac{N^{II}}{N^I}\right)^2}{1 + \left(\frac{N^{II}}{N^I}\right)^2}$$

$$= 1 - \left(\frac{\lambda^I}{\lambda}\right)^2 = \left(\frac{\lambda^{II}}{\lambda}\right)^2 - 1 = \frac{1 - \left(\frac{\lambda^{II}}{\lambda^I}\right)^2}{1 + \left(\frac{\lambda^{II}}{\lambda^I}\right)^2}$$

In the following table, the degree of coupling is given in percentage; thus for $K' = 0.02$ the figure given is 2 (per cent.).

I		II		III	
$\frac{\lambda^I}{\lambda}$ or $\frac{N}{N^I}$	Percentage coupling	$\frac{\lambda^{II}}{\lambda}$ or $\frac{N}{N^{II}}$	Percentage coupling	$\frac{\lambda^I}{\lambda^{II}}$ or $\frac{N^{II}}{N^I}$	Percentage coupling
0.999	0.20	1.001	0.20	1.001	0.100
0.998	0.40	1.002	0.40	1.002	0.200
0.997	0.60	1.003	0.60	1.003	0.299
0.996	0.80	1.004	0.80	1.004	0.398
0.995	1.00	1.005	1.00	1.005	0.498
0.994	1.20	1.006	1.20	1.006	0.596
0.993	1.40	1.007	1.40	1.007	0.695
0.992	1.59	1.008	1.61	1.008	0.799
0.991	1.79	1.009	1.81	1.009	0.897
0.99	1.99	1.01	2.01	1.01	0.99
0.98	3.96	1.02	2.04	1.02	1.98
0.97	4.91	1.03	6.09	1.03	2.97
0.96	7.84	1.04	8.16	1.04	3.92
0.95	9.75	1.05	10.2	1.05	4.87
0.94	11.6	1.06	12.4	1.06	5.82
0.93	13.5	1.07	14.5	1.07	6.76
0.92	15.4	1.08	16.6	1.08	7.68
0.91	17.2	1.09	18.8	1.09	8.60
0.90	19.0	1.10	21.0	1.10	9.50
0.89	20.8	1.11	23.2	1.11	10.4
0.88	22.6	1.12	25.4	1.12	11.3
0.87	24.3	1.13	27.7	1.13	12.2
0.86	26.0	1.14	30.0	1.14	13.0
0.85	27.8	1.15	32.2	1.15	13.9

Table X. (Continued)

I		II		III	
$\frac{\lambda^I}{\lambda}$ or $\frac{N}{N^I}$	Percentage coupling	$\frac{\lambda^{II}}{\lambda}$ or $\frac{N}{N^{II}}$	Percentage coupling	$\frac{\lambda^I}{\lambda^{II}}$ or $\frac{N^{II}}{N^I}$	Percentage coupling
0.84	29.4	1.16	34.6	1.16	14.7
0.83	31.1	1.17	36.9	1.17	15.6
0.82	32.8	1.18	39.2	1.18	16.4
0.81	34.4	1.19	41.6	1.19	17.2
0.80	36.0	1.20	44.0	1.20	18.0
0.79	37.6	1.21	46.4	1.21	18.8
0.78	39.2	1.22	48.8	1.22	19.6
0.77	40.7	1.23	51.3	1.23	20.4
0.76	42.2	1.24	53.8	1.24	21.2
0.75	43.8	1.25	56.2	1.25	22.0
0.74	45.2	1.26	58.8	1.26	22.7
0.73	46.7	1.27	61.3	1.27	23.5
0.72	48.2	1.28	63.8	1.28	24.2
0.71	49.6	1.29	66.4	1.29	24.9
0.70	51.0	1.30	69.0	1.30	25.6
0.69	52.4	1.31	26.4
0.68	53.8	1.32	27.1
0.67	55.1	1.33	27.8
0.66	56.4	1.34	28.5
0.65	57.8	1.35	29.1
0.64	59.0	1.36	29.8
0.63	60.3	1.37	30.5
0.62	61.6	1.38	31.1
0.61	62.8	1.39	31.8
0.60	64.0	1.40	32.4
....	1.41	33.0
....	1.42	33.7
....	1.43	34.3
....	1.44	34.9
....	1.45	35.5
....	1.46	36.1
....	1.47	36.7
....	1.48	37.3
....	1.49	37.9
....	1.50	38.5
....	1.55	41.2
....	1.60	43.8
....	1.65	46.3
....	1.70	48.6
....	1.75	50.7
....	1.80	52.8
....	1.85	54.8
....	1.90	56.6
....	1.95	58.4
....	2.00	60.0

Table XI.—Resonance Curve of the Current Effect [Art. 74a]

Let d_1 and d_2 represent the decrements of the primary and secondary circuits, respectively, I_{eff}^2 the current effect in the secondary circuit and I_r^2 the same at resonance between the two circuits. The resonance curve is obtained by plotting the values of the ratio $I_{eff}^2 : I_r^2$ as ordinates, y , and the values of the dissonance between the two circuits as abscissæ. Let $x = \frac{x_1 + x_2}{2}$, the meaning of x_1 and x_2 being obvious from Fig. 470. Then:

$$d_1 + d_2 = x \times 2\pi \sqrt{\frac{y}{1-y}}$$

$$= xA$$

The assumptions are:

1. $x \ll 1.0$.
2. $d_1 + d_2 \ll 2\pi$ and
3. Very loose coupling between primary and secondary circuits.

In the following table the value of A and $\log A$ is given for different values of y .

y	$\log A$	A	y	$\log A$	A
0.998	2.1472	140	0.958	1.4773	30.0
0.996	1.9963	99.2	0.956	1.4667	29.3
0.994	1.9078	80.9	0.954	1.4565	28.6
0.992	1.8449	70.0	0.952	1.4469	28.0
0.990	1.7960	62.5	0.950	1.4376	27.4
0.988	1.7560	57.0	0.945	1.4157	26.0
0.986	1.7221	52.7	0.940	1.3956	24.9
0.984	1.6926	49.3	0.935	1.3771	23.8
0.982	1.6666	46.4	0.930	1.3599	22.9
0.980	1.6433	44.0	0.925	1.3437	22.1
0.978	1.6221	41.9	0.920	1.3285	21.3
0.976	1.6028	40.1	0.915	1.3142	20.6
0.974	1.5850	38.5	0.910	1.3006	20.0
0.972	1.5684	37.0	0.905	1.2876	19.4
0.970	1.5530	35.7	0.900	1.2753	18.8 ₅
0.968	1.5386	34.5	0.89	1.2522	17.9
0.966	1.5249	33.5	0.88	1.2308	17.0
0.964	1.5121	32.5	0.87	1.2110	16.3
0.962	1.4994	31.6	0.86	1.1924	15.6
0.960	1.4883	30.8	0.85	1.1748	15.0

Table XI. (Continued)

y	$\log A$	A	y	$\log A$	A
0.84	1.1583	14.4	0.39	0.7011	5.02
0.83	1.1425	13.9	0.38	0.6919	4.92
0.82	1.1274	13.4	0.37	0.6827	4.82
0.81	1.1130	13.0	0.36	0.6734	4.71
0.80	1.0993	12.6	0.35	0.6638	4.61
0.79	1.0859	12.2	0.34	0.6542	4.51
0.78	1.0730	11.8	0.33	0.6444	4.41
0.77	1.0606	11.5	0.32	0.6345	4.31
0.76	1.0485	11.2	0.31	0.6245	4.21
0.75	1.0367	10.9	0.30	0.6142	4.11
0.74	1.0253	10.6	0.29	0.6033	4.01
0.73	1.0141	10.3	0.28	0.5932	3.92
0.72	1.0032	10.1	0.27	0.5823	3.82
0.71	0.9931	9.84	0.26	0.5711	3.72
0.70	0.9822	9.60	0.25	0.5597	3.63
0.69	0.9719	9.37	0.24	0.5479	3.53
0.68	0.9619	9.16	0.23	0.5358	3.43
0.67	0.9518	8.95	0.22	0.5234	3.34
0.66	0.9422	8.75	0.21	0.5105	3.24
0.65	0.9326	8.56	0.20	0.4971	3.14
0.64	0.9230	8.38	0.19	0.4834	3.04
0.63	0.9137	8.20	0.18	0.4690	2.94
0.62	0.9045	8.03	0.17	0.4539	2.84
0.61	0.8953	7.86	0.16	0.4381	2.74
0.60	0.8862	7.69	0.15	0.4216	2.64
0.59	0.8772	7.54	0.14	0.4040	2.54
0.58	0.8683	7.38	0.13	0.3854	2.43
0.57	0.8594	7.23	0.12	0.3656	2.32
0.56	0.8505	7.09	0.11	0.3442	2.21
0.55	0.8418	6.95	0.10	0.3211	2.09
0.54	0.8330	6.81	0.09	0.2958	1.98
0.53	0.8243	6.67	0.08	0.2679	1.85
0.52	0.8156	6.54	0.07	0.2365	1.72
0.51	0.8069	6.41	0.06	0.2008	1.59
0.50	0.7982	6.28	0.05	0.1588	1.44
0.49	0.7895	6.16	0.04	0.1081	1.28
0.48	0.7808	6.04	0.03	0.0434	1.10
0.47	0.7721	5.92	0.02	0.9531-1	0.90
0.46	0.7634	5.80	0.01	0.8004-1	0.63
0.45	0.7546	5.68			
0.44	0.7459	5.57			
0.43	0.7370	5.46			
0.42	0.7281	5.35			
0.41	0.7192	5.24			
0.40	0.7102	5.13			

Table XII.—Resonance Sharpness $\rho = \frac{2\pi}{d_1 + d_2}$ [Art. 70c]

$d_1 + d_2$	ρ	$d_1 + d_2$	ρ	$d_1 + d_2$	ρ	$d_1 + d_2$	ρ
0.010	628	0.033	190	0.056	112	0.079	79.4
0.011	571	0.034	185	0.057	110	0.080	78.5
0.012	524	0.035	179.5	0.058	108		
0.013	483			0.059	106.5	0.081	77.6
0.014	449	0.036	174.5	0.060	105	0.082	76.6
0.015	419	0.037	170			0.083	75.7
		0.038	165	0.061	103	0.084	74.8
0.016	393	0.039	161	0.062	101	0.085	73.9
0.017	370	0.040	157	0.063	99.7		
0.018	349			0.064	98.2	0.086	73.1
0.019	331	0.041	153	0.065	96.7	0.087	72.2
0.020	314	0.042	150			0.088	71.4
		0.043	146	0.066	95.2	0.089	70.6
0.021	299	0.044	143	0.067	93.8	0.090	69.8
0.022	286	0.045	140	0.068	92.4		
0.023	273			0.069	91.1	0.091	69.0
0.024	262	0.046	137	0.070	89.8	0.092	68.3
0.025	251	0.047	134			0.093	67.6
		0.048	131	0.071	88.5	0.094	66.8
0.026	242	0.049	128	0.072	87.3	0.095	66.1
0.027	233	0.050	126	0.073	86.1		
0.028	224			0.074	85.0	0.096	65.5
0.029	217	0.051	123	0.075	83.8	0.097	64.8
0.030	209	0.052	121			0.098	64.1
		0.053	118.5	0.076	82.7	0.099	63.5
0.031	203	0.054	116	0.077	81.6	0.100	62.8
0.032	196	0.055	114	0.078	80.5		

Table XIII.—The Radiation Resistance of Antennæ

According to Art. 100c, the radiation resistance, R_Σ , of an antenna whose height is h and form factor is α and which is erected on ground of high conductivity, is given by:

$$R_\Sigma = 160\pi^2 \left(\frac{\alpha h}{\lambda}\right)^2 = \alpha^2 \times 160\pi^2 \left(\frac{h}{\lambda}\right)^2 \text{ ohms.}$$

In the following table the different values of the expression $160\pi^2 \left(\frac{\alpha h}{\lambda}\right)^2$ are given. Hence the radiation resistance in ohms is found by multiplying the figure given in the table by the square of the form factor of the antenna.

	Wave length λ in meters									
	300	400	500	600	700	800	900	1000	1500	2000
10	1.75 ₅	0.987	0.632	0.439	0.332	0.247	0.195	0.158	0.0702	0.0395
15	3.95	2.22	1.42	0.987	0.725	0.555	0.439	0.355	0.158	0.088
20	7.02	3.95	2.53	1.75 ₅	1.29	0.987	0.780	0.632	0.281	0.158
25	11.0	6.17	3.95	2.74	2.01	1.54	1.22	0.987	0.439	0.247
30	15.8	8.88	5.68 ₅	3.95	2.90	2.22	1.75	1.42	0.634	0.355
35	21.5	12.1	7.74	5.37 ₅	3.95	3.02	2.39	1.93	0.860	0.484
40	28.1	15.8	10.1	7.02	5.16	3.95	3.12	2.53	1.12	0.632
45	35.5	20.0	12.8	8.88	6.53	5.00	3.95	3.20	1.42	0.800
50	43.9	24.7	15.8	11.0	8.06	6.17	4.87	3.95	1.75	0.987
55	53.1	29.8	19.1	13.3	9.79	7.46	5.90	4.78	2.12	1.19
60	63.2	35.5	22.7	15.8	11.6	8.88	7.02	5.68 ₅	2.53	1.42
65	74.1	41.7	26.7	18.5	13.6	10.4	8.24	6.67	2.96 ₅	1.67
70	86.0	48.4	30.9 ₅	21.5	15.8	12.1	9.55	7.74	3.44	1.93 ₅
75	98.7	55.4	35.5	24.7	18.1	13.9	11.0	8.88	3.95	2.22
80	63.2	40.4	28.1	20.6	15.8	12.5	10.1	4.49	2.53
85	71.3	45.6	31.7	23.3	17.8	14.1	11.4	5.07	2.85
90	80.0	51.2	35.5	26.1	20.0	15.8	12.8	5.68 ₅	3.20
95	89.1	57.0	39.6	29.1	22.3	17.6	14.2 ₅	6.33 ₅	3.56
100	98.7	63.2	43.9	32.2	24.7	19.5	15.8	7.02	3.95
110	76.4	53.1	39.0	29.8 ₅	23.6	19.1	8.49	4.78
120	90.9 ₅	63.2	46.4	35.5	28.1	22.7	10.1	5.68 ₅
130	74.1	54.5	41.7	32.9	26.7	11.9	6.67
140	86.0	63.2	48.4	38.2	30.9 ₅	13.8	7.74
150	98.7	72.5	55.4	43.9	35.5	15.8	8.88
160	82.5	63.2	49.9	40.4	18.0	10.1
170	93.1	71.3	56.3	45.6	20.3	11.4
180	80.0	63.2	51.2	22.7	12.8
190	89.1	70.4	57.0	25.3	14.2
200	98.7	78.0	63.2	28.1	15.8

	Wave length λ in meters									
	2500	3000	3500	4000	4500	5000	5500	6000	6500	7000
10	0.0253	0.0175 ₅	0.0129	0.00987	0.00780	0.00632	0.0052	0.00439	0.0037	0.00332
15	0.0568	0.0395	0.0290	0.0222	0.0176	0.0142	0.0117	0.00987	0.0084	0.00725
20	0.101	0.0702	0.0516	0.0395	0.0312	0.0253	0.0209	0.0175 ₅	0.0149 ₅	0.0129
25	0.158	0.110	0.0806	0.0617	0.0487	0.0395	0.0326	0.0274	0.0234	0.0210
30	0.227	0.158	0.116	0.0888	0.0702	0.0568 ₅	0.0470	0.0395	0.0336	0.0290
35	0.309 ₅	0.215	0.158	0.121	0.0955	0.0774	0.0639 ₅	0.0537 ₅	0.0458	0.0395
40	0.404	0.281	0.206	0.158	0.125	0.101	0.0835	0.0702	0.0598	0.0516
45	0.512	0.355	0.261	0.200	0.158	0.128	0.106	0.0888	0.0757	0.0653
50	0.632	0.439	0.322	0.247	0.195	0.158	0.130 ₅	0.110	0.0934	0.0806
55	0.764	0.531	0.390	0.298 ₅	0.236	0.191	0.158	0.133	0.113	0.0979
60	0.910	0.632	0.464	0.355	0.281	0.227	0.188	0.158	0.134	0.116
65	1.07	0.741	0.544	0.417	0.329	0.267	0.221	0.185	0.158	0.136
70	1.24	0.860	0.631	0.484	0.382	0.309 ₅	0.256	0.215	0.183	0.158
75	1.42	0.987	0.725	0.554	0.439	0.355	0.294	0.247	0.210	0.181
80	1.62	1.12	0.825	0.632	0.499	0.404	0.334	0.281	0.239	0.206
85	1.83	1.27	0.931	0.713	0.563	0.456	0.377	0.317	0.270	0.233
90	2.05	1.42	1.04	0.800	0.632	0.512	0.423	0.355	0.303	0.261
95	2.28	1.58	1.16	0.891	0.704	0.570	0.471	0.396	0.337	0.291
100	2.53	1.75 ₅	1.29	0.987	0.780	0.632	0.522	0.439	0.374	0.322
110	3.06	2.12	1.56	1.19	0.943 ₅	0.764	0.632	0.531	0.452	0.390
120	3.64	2.53	1.86	1.42	1.12	0.910	0.752	0.632	0.538	0.464
130	4.27	2.96 ₅	2.18	1.67	1.32	1.07	0.882	0.741	0.631	0.545
140	4.95	3.44	2.53	1.93	1.53	1.24	1.02	0.860	0.732	0.632
150	5.68 ₅	3.95	2.90	2.22	1.76	1.42	1.17	0.987	0.840	0.725
160	6.47	4.49	3.30	2.53	2.00	1.62	1.34	1.12	0.957	0.825
170	7.30	5.07	3.72 ₅	2.85	2.25	1.83	1.51	1.27	1.08	0.931
180	8.19	5.68 ₅	4.18	3.20	2.53	2.05	1.69	1.42	1.21	1.04
190	9.12	6.33 ₅	4.65	3.56	2.81 ₅	2.28	1.88 ₅	1.58	1.35	1.16
200	10.1	7.02	5.16	3.95	3.12	2.53	2.09	1.75	1.49 ₅	1.29

Height of antenna in meters

BIBLIOGRAPHY AND NOTES ON THEORY

¹ Works covering the general subject of radio-telegraphy:

- a. F. ANDERLE, Lehrbuch der drahtlosen Telegraphie und Telephonie, Leipzig and Vienna, 1912.
- b. J. ERSKINE-MURRAY, A handbook of wireless telegraphy, its theory and practice. 3d Edit., London, 1911.
- c. J. A. FLEMING, The principles of electric wave telegraphy. 2d Edit., London, Longmans, Green & Co., 1910.
- d. G. W. PIERCE, Principles of wireless telegraphy. New York, McGraw-Hill Book Co., 1910.
- e. H. REIN, Radiotelegraphisches Praktikum. 2d Edit., Berlin, Springer, 1912.
- f. C. TISSOT, Manuel élémentaire de télégraphie sans fil. Paris, 1912.
- g. A. ZAMMARCI, La telegraphia senza fili di Guglielmo Marconi. Bergamo, 1904. (Of historical interest only.)
- h. J. ZENNECK, Elektromagnetische Schwingungen und drahtlose Telegraphie. Stuttgart, 1905.^a
- i. Theoretical: C. TISSOT, Les oscillations électriques. Paris, 1910.

² Special arrangements for the use of the Braun tube with rapid oscillations: L. MANDELSTAM, Jahrb., **1**, 124, 1908. (The same method employed by D. ROSCHANSKY, Ann. Phys., **36**, 281, 1911.) H. HAUSRATH, Phys. Zeitschr., **12**, 1044, 1911; also Jahrb., **6**, 185, 1912. K. ORT, Jahrb., **6**, 119, 1912. E. L. CHAFFEE, Proc. Amer. Acad. Arts and Sciences, **47**, 311 *et seq.*, 1911.

³ W. FEDDERSEN, Pogg. Ann., **113**, 437, 1861; also **116**, 132, 1862. Also see Berichte der sächs. Ges. der Wissenschaften, **61**, 151, 1909. For frequency determinations, the method of HEMSALECH (C. R., **132**, 912, 1901, illumination of a slit by the spark) gives particularly suitable pictures.

⁴ E. GEHRKE, Verhandl. Physik. Ges., **6**, 176, 1904; Zeitschr. f. Instrumentenkunde, **15**, 33, 278, 1905. Reproductions by means of the incandescent lamp oscillograph: H. DIESSELHORST, Ber. phys. Ges., **5**, 320, 1907; **6**, 306, 1908; *ETZ*, **29**, 703, 1908.

⁵ W. THOMSON, Phil. Mag. (4), **5**, 593, 1855.

⁶ J. A. FLEMING, Elecn., **63**, 459, 1909. H. ANDERSON, Phys. Rev., **34**, 34, 1912.

⁷ M. WIEN, Phys. Zeitschr., **11**, 282 *et seq.*, 1910. H. RIEGGER, Diss. Strassburg, 1911; Jahrb., **5**, 35, 1911. For explanation, see D. ROSCHANSKY, Phys. Zeitschr., **11**, 1177, 1910.

⁸ In regard to more recent work, see H. DIESSELHORST, Jahrb., **1**, 263, 1908.

⁹ To be more accurate, this should be $\frac{1}{2}LI_0^2$, the energy transferred in a half cycle (see E. COHN, Das elektromagnetische Feld, p. 360. Leipzig, 1900).

¹⁰ F. RICHARZ and W. ZIEGLER, Ann. Phys., **1**, 468, 1900. J. ZENNECK, Ann. Phys., **13**, 822, 1904.

¹¹ This refers to gaps in air. According to E. L. CHAFFEE,² a straight line amplitude curve is also obtained with aluminium electrodes in hydrogen and with carbon electrodes in air.

¹² A. HEYDWEILLER, Ann. Phys., **19**, 649, 1906; **25**, 48, 1908. W. STUFF, Diss. Münster, 1907. H. BARKHAUSEN, Phys. Zeitschr., **8**, 624, 1907.

¹³ That is, R_g is defined by

$$R_g \int_0^{\infty} I^2 dt = \int_0^{\infty} I V_g dt$$

= the energy consumed during one spark discharge.

¹⁴ This arrangement was proposed by MARESCA (Phys. Zeitschr., **4**, 9, 1902), and the method, in the form described in the text, by K. SIMONS (Ann. Phys., **13**, 1044, 1904).

¹⁵ Determinations of the gap resistance or decrement: G. REMPP, Diss. Strassburg and Ann. Phys., **17**, 627, 1905. (His values, particularly for gaps over 6 mm. long, are too high as the effect of brush discharge was not understood at that time.) H. RAUSCH VON TRAUBENBERG and W. HAHNEMANN, Phys. Zeitschr., **8**, 498, 1907. K. E. F. SCHMIDT, Phys. Zeitschr., **8**, 617, 1907. C. RICHTER, Phys. Zeitschr., **10**, 703, 1909. M. WIEN, Ber. physik. Ges., **12**, 736, 1910; Ann. Phys., **29**, 679 *et seq.*, 1909. W. F. ZORN, Jahrb., **4**, 269 *et seq.*, 382 *et seq.*, 1911.

$$I_0 = \frac{V_0}{\omega L} = V_0 \sqrt{\frac{C}{L}}$$

also

$$R_g = \frac{A}{I_0}$$

whence

$$R_g = \frac{A}{V_0} \sqrt{\frac{L}{C}}$$

$$d_g = \pi R_g \sqrt{\frac{C}{L}} = \frac{\pi A}{V_0}$$

¹⁷ M. WIEN, Ann. Phys., **29**, 679 *et seq.*, 1909.

¹⁸ Measurements by W. EICKHOFF at the physikalisches Institut Braunschweig (see Phys. Zeitschr., **8**, 497, 1907).

¹⁹ D. ROSCHANSKY, Jahrb., **3**, 81, 1909.

²⁰ W. EICKHOFF, Phys. Zeitschr., **8**, 494, 1907. In regard to the voltage conditions in series spark gaps see P. NORDMEYER, Jahrb., **3**, 334 *et seq.*, 1910.

²¹ B. MONASCH, Ann. Phys., **22**, 905, 1907. W. HAHNEMANN and L. ADELMANN, *ETZ*, **1907**, 988, 1010. M. WIEN.¹⁷ J. A. FLEMING and G. B. DYKE, *El.*, **66**, 658 *et seq.*, 1911. L. W. AUSTIN, *Jahr.* **5**, 420, 1912. According to AUSTIN the glass furnished by the Wireless Specialty Apparatus Co. is particularly good.

²² This phenomenon is identical with the "corona" of high-tension transmission circuits (see, e.g., W. PETERSEN, Hochspannungstechnik, p. 308 *et seq.*, Stuttgart, 1911).

²³ A. MEISSNER, Jahrb., **3**, 57 *et seq.*, 1909.

²⁴ Detailed treatment in *EMS*, p. 498 *et seq.*, 743 *et seq.* (Note 1 h)

²⁵ According to F. HARMS (Ann. Phys., **23**, 60, 1907) the velocity of propagation and hence also the frequency are less for wires with an insulating sheath.

²⁶ M. ABRAHAM, Wied. Ann., **66**, 435 *et seq.* F. HACK, Ann. Phys., **14**, 539, 1904. The field of an oscillator whose current amplitude is the same at all points ($\alpha = 1$) has been calculated by H. HERTZ, Wied. Ann., **36**, 1, 1888; Ges. Werke II, 45.

²⁷ F. HACK, Ann. Phys., **18**, 634, 1905.

²⁸ Detailed treatment of oscillations in coils, P. DRUDE, Ann. Phys., **9**, 593, 1902. J. A. FLEMING.¹

²⁹ M. WIEN, Jahrb., **1**, 474, 1908.

³⁰ G. SEIBT, *ETZ*, **1902**, 411. Also experiments in the physikal. Inst. Braunschweig.

³¹ This follows from the well-known "telegraph equation" of KIRCHHOFF. See, *e.g.*, B. C. TISSOT.¹

³² Experimental method for determining the current anti-node in an open oscillator, A. ESAU, *Phys. Zeitschr.*, **13**, 495, 1912.

³³ If the current, I , is of the form

$$I = I_0 \sin \omega t,$$

then at a distance r ,

$$E = E_0 \cos \left(\omega t - \frac{2\pi r}{\lambda} \right) \text{ and } M = M_0 \cos \left(\omega t - \frac{2\pi r}{\lambda} \right).$$

(The algebraic sign before E and M being in accordance with Fig. 37, p. 35, I is taken positive in direction from A to B .)

³⁴ M. ABRAHAM, *Theorie der Elektrizität II*, p. 286. Leipzig, 1905. Application to various forms of oscillators by A. MONTEL, *Lum. él.*, **6**, 199, 207, 1909.

³⁵ $I_0 = \frac{1}{l} \int_0^l I_0 dx$ (l = length of oscillator).

³⁵ In this case, we have for each half of the oscillator,

$$I_0 = |I_0| \left(1 - \frac{x}{\frac{l}{2}} \right)$$

$$\alpha = \frac{\frac{1}{2} \int_0^{\frac{l}{2}} I_0 dx}{|I_0|} = \frac{1}{2}$$

where x = distance from middle of oscillator. Hence

³⁷ Here

$$I_0 = |I_0| \cos \frac{\pi x}{l}$$

$$\alpha = \frac{\frac{1}{l} \int_{-\frac{l}{2}}^{+\frac{l}{2}} I_0 dx}{|I_0|} = 2\pi$$

^{37a} This follows directly from the fact that the radiation $\Sigma = \frac{1}{4\pi} [EM]$ in which $[EM]$ is the product of the vectors E and M .

³⁸ This is easily arrived at from M. ABRAHAM,³⁴ p. 301 *et seq.*

³⁹ R. RÜDENBERG, *Ann. Phys.*, **25**, 446, 1908. Also see H. BARKHAUSEN, *Jahrb.*, **2**, 40, 1908. P. BARRECA, *Jahrb.*, **4**, 31 *et seq.*, 1910.

⁴⁰ All difficulties which otherwise are apt to be encountered in coupled circuits can be avoided by proceeding as follows: At any point x on the oscillator, the current is

$$I = |I| f(x); \quad V = |V| \varphi(x)$$

Furthermore let the energy consumed per second as heat be expressed by

$$\int R^{(1)} \times I^2 dx = |I|^2 \int R^{(1)} f(x)^2 dx$$

(the integral in this and the following includes the entire oscillator), the energy of the magnetic field, so far as the oscillations are concerned, by

$$\frac{1}{2} \int L^{(1)} I^2 dx = \frac{1}{2} |I|^2 \int L^{(1)} f(x)^2 dx$$

and the energy of the electrical field by

$$\frac{1}{2} \int C^{(1)} V^2 dx = \frac{1}{2} |V|^2 \int C^{(1)} \varphi(x)^2 dx$$

Moreover

$$|I|^2 = \int C^{(1)} \frac{\delta V}{dt} dx = \frac{\delta |V|}{dt} \int C^{(1)} \varphi(x)^2 dx$$

The differential equation of the oscillation is then:

$$|I|^2 \int R^{(1)} f(x)^2 dx + \frac{\delta}{\delta t} \cdot \frac{1}{2} |I|^2 \int L^{(1)} f(x)^2 dx + \frac{\delta}{\delta t} \cdot \frac{1}{2} |V|^2 \int C^{(1)} \varphi(x)^2 dx = 0$$

or

$$\frac{\delta |I|}{\delta t} \cdot \int R^{(1)} f(x)^2 dx + \frac{\delta^2 |I|}{\delta t^2} \int L^{(1)} f(x)^2 dx + |I| \cdot \frac{\int C^{(1)} \varphi(x)^2 dx}{\left\{ \int C^{(1)} \varphi(x) dx \right\}^2} = 0$$

This can be reduced to the same form as pertains to the natural oscillations of a condenser circuit, viz.:

$$R \frac{\delta |I|}{\delta t} + L \frac{\delta^2 |I|}{\delta t^2} + \frac{|I|}{C} = 0$$

by substituting the values:

$$R = \int R^{(1)} f(x)^2 dx,$$

$$L = \int L^{(1)} f(x)^2 dx \text{ and}$$

$$C = \int C^{(1)} \varphi(x)^2 dx \left\{ \frac{\int C^{(1)} \varphi(x) dx}{\int C^{(1)} \varphi(x)^2 dx} \right\}^2$$

The preceding applies to oscillators without condensers in series but is easily modified so as to apply to oscillators having series condensers.

⁴¹ A. BLONDEL, Assoc. franc. pour l'avancement des sciences. Congrès d'Angers, 1903.

⁴² Elementary treatment of the action of capacities and inductive coils in antennæ, see, e.g., A. GUYAU, Lum. él., **15**, 13, 1911.

⁴³ Detailed treatment in *EMS*, p. 400 *et seq.*

⁴⁴ Discussions of coefficients of self-induction and mutual induction: G. GLAGE, *Jahrb.*, **2**, 361 *et seq.*, 501 *et seq.*, 593 *et seq.*, 1909, and particularly E. B. ROSA and F. W. GROVER, *Bullet. Bur. of Standards*, **8**, 1 *et seq.*, 1911.

⁴⁵ Articles on the resistance, self-induction and capacity of coils of solid wire and wire braid: (1) Theoretical: A. SOMMERFELD, *Ann. Phys.*, **24**, 609, 1907. J. W. NICHOLSON, *Jahrb.*, **4**, 26 *et seq.*, 1910. L. COHEN, *Bull. Bur. of Standards*, **4**, No. 76, 1907-1908. W. LENZ, *Ann. Phys.*, **37**, 923, 1912. H. G. MÖLLER, *Ann. Phys.*, **36**, 738 *et seq.*, 1911 (regarding braided wires). Experimental: TH. P. BLACK, *Ann. Phys.*, **19**, 157, 1906. A. MEISSNER.²³ A. ESAU, reference list summarizing his articles: *Jahrb.*, **4**, 490 *et seq.*, 1911. R. LINDE-

- MANN, reference list of articles: *Jahrb.*, **4**, 561 *et seq.*, 1911. K. HERRMANN, *Verh. physik. Ges.*, **13**, 978, 1911.
- ⁴⁶ Concerning the effective resistance of wires subjected to two simultaneous undamped, sinusoidal and damped, non-sinusoidal oscillations: BRÝLINSKI, *Bull. de la soc. intern. des électriciens* (2), **6**, 255, 1906.
- ⁴⁷ Rheostat, for rapid oscillations, of wires having small cross-section and low conductivity: C. TISSOT, *Bull. de la Soc. intern. des élect.* (2), **6**, 340, 1906. W. HAHNEMANN, *Jahrb.*, **2**, 314, 1909.
- ⁴⁸ P. BRENOT, *Lum. él.*, **15**, 259 *et seq.*, 1911.
- ⁴⁹ Resistance and current distribution in rectangular wire (bands): W. EDWARDS, *EL.*, **68**, 18, 1912 (theoretical). J. BETHENOD, *Jahrb.*, **2**, 379 *et seq.*, 1909 (experimental).
- ⁵⁰ N. TESLA'S researches in polyphase currents, etc., by TH. C. MARTIN, pp. 222, 314. (Halle, 1895.)
- ⁵¹ Construction of C. LORENZ Co. to whose courtesy the illustration is due.
- ^{51a} This is not the only possibility. For instance, the same image would be produced if the discharge frequency and the revolutions per second were in the ratio 3:4 or 5:4.
- ⁵² E. NESPER, *Jahrb.*, **2**, 92 *et seq.*, 319 *et seq.*, **3**, 376 *et seq.*, 1910.
- ⁵³ The Rendahl variometer was apparently proposed independently by PÉRI (see *ETZ*, **32**, 247, 1911).
- ⁵⁴ Thanks are due to the DR. E. F. HUTH, G. m. b. H., Berlin, SO, Erdmannshof, for this illustration.
- ⁵⁵ Thanks are due to DR. L. COHEN (Nat. Elec. Sign. Co.), for this illustration.
- ⁵⁶ See J. MOSCICKI, *ETZ*, **25**, 527, 1904. C. MÜLLER (*Ann. Phys.*, **28**, 585 *et seq.*, 1909) also proposed a good form of jar.
- ⁵⁷ Compressed air (or gas) condensers, proposed by T. JERVIS-SMITH (*Nature*, **48**, 64, 1893, quoted in *EL.*, **55**, 912, 1905). R. FESSENDEN, *ETZ*, 1905, 950. M. WIEN.¹⁷
- In regard to the dielectric strength of compressed gases see M. WOLF, *Wied. Ann.*, **37**, 306, 1889, and E. A. WATSON, *Journ. Inst. Elec. Eng.*, **40**, 6, 1908.
- ^{57a} According to G. W. PIERCE,¹ p. 114, the variable condenser was proposed by KORDA as early as 1893.
- ⁵⁸ From a pamphlet of the physikalisch-technischen Laboratorium: DR. G. SEIBT, Berlin-Schöneberg.
- ⁵⁹ From *Jahrb.*, **4**, 439, 1911.
- ⁶⁰ Construction of H. BOAS Co. (Berlin).
- ⁶¹ From *Jahrb.*, **4**, 229, 1911.
- ⁶² See P. BRENOT, *Lum. él.* (2), **11**, 427, 1910.
- ⁶³ This, of course, also follows directly from $I = -C \frac{\delta V}{\delta t}$.
- ⁶⁴ Gap length and breakdown potential: A. HEYDWEILLER, *Wied. Ann.*, **48**, 235, 1893. S. M. KINTNER, *Proc. Amer. Inst. El. Eng.*, **24**, 523, 1905. J. A. FLEMING,¹ More recent works are: J. ALGERMISSEN.⁶⁵ E. VOIGT, *Ann. Phys.*, **12**, 403, 1903. C. MÜLLER⁶⁶ (in conjunction with MÜLLER, see M. TOEPLER, *Ann. Phys.*, **29**, 153, 1909). E. HUPKA, *Ann. Phys.*, **36**, 440 *et seq.*, 1911. W. WEICKER, *ETZ*, **32**, 436 *et seq.*, 460 *et seq.*, 1911. In regard to principal points in measurement of gap length see M. TOEPLER, *Ann. Phys.*, **19**, 191, 1906; *ETZ*, **28**, 998 *et seq.*, 1907.
- ⁶⁵ See J. ALGERMISSEN, *Diss. Strassburg*, 1906; *Ann. Phys.*, **19**, 1016, 1906.
- ⁶⁶ E. WARBURG, *Wied. Ann.*, **59**, 1, 1896; **62**, 385, 1897.
- ⁶⁷ If V is the potential across a poor insulator of resistance R , then the quantity of electricity which is lost by leakage through the insulator in a given time, t ,

is equal to $\frac{1}{R} \int_0^t |V| dt$ (in which $|V|$ is the absolute value of V). The quantity lost, therefore, increases as the duration of the potential increases.

Concerning insulating materials for rapid oscillations see S. H. HILLS, *El.*, **65**, 303, 1910.

⁶⁸
$$I^2_{eff} = \frac{1}{t} \int_0^t I^2 dt$$

⁶⁹
$$= R \int_0^\infty I^2 dt \text{ for } I = I_0 e^{-\frac{d}{T}t} \cdot \sin \omega t \text{ and } d \ll 2\pi \text{ [Art. 8c].}$$

⁷⁰ For one discharge we have $\int_0^{T/a} I^2 dt = \frac{1}{6Na} I_0^2$, if $I = I_0 \left(1 - \frac{a}{T} t\right) \sin \omega t$ and $a \ll 1$ [Art. 9a].

⁷¹ See A. WASMUS, *Diss. Braunschweig*, 1909. *ETZ*, **31**, 199, 1910.

⁷² *Jahr.*, **5**, 517, 1911; *Jahr.*, **6**, 28, 1913. W. STEINHAUS *Phys. Zeitschr.*, **12**, 657, 1911.

⁷³ A. ESPINOSA DE LOS MONTEROS, *Jahr.*, **1**, 323, 1908.

⁷⁴ Articles on bolometers: C. TISSOT, *Ann. Chim. Phys.* (8), **7**, 1906 or separately: *Etude de la r sonance des syst mes d'antennes*, p. 20 *et seq.*, Paris, 1906. K. E. F. SCHMIDT, *Phys. Zeitschr.*, **8**, 601, 1907. B LA G TI, *El.*, **58**, 983, 1907; *Jahr.*, **2**, 109, 1908; *Phys. Zeitschr.*, **10**, 322, 897, 1909. J. RAUTENKRANZ, *Phys. Zeitschr.*, **10**, 93, 1909. H. Z LLICH, *Phys. Zeitschr.*, **10**, 899, 1909. W. KEMPE, *Phys. Zeitschr.*, **11**, 331, 1910. B. S. COHEN, *Journ. Inst. El. Eng.*, **39**, 503, 1907.

⁷⁵ Articles on thermocouples: H. BRANDES, *Phys. Zeitschr.*, **6**, 503, 1905. W. VOLGE, *ETZ*, **1906**, 467. L. W. AUSTIN, *Phys. Zeitschr.*, **12**, 1133, 1226, 1911. C. M. DOWSE, *El.*, **65**, 765, 1910.

⁷⁶ W. DUDELL, *Phil. Mag.* (6), **8**, 91, 1904; *Electrician*, **55**, 260, 1905.

⁷⁷ W. GERLACH, *Phys. Zeitschr.*, **13**, 589, 1912.

⁷⁸ A. ESPINOSA DE LOS MONTEROS, *Jahr.*, **1**, 327, 1908.

⁷⁹ L. W. AUSTIN, *Bull. Bur. Stand.*, **7**, 315, 1911; *Phys. Zeitschr.*, **12**, 1133, 1911. According to the latter article, the "perikon" detector produced a deflection of 3 scale divisions in a 2000 ohm galvanometer (1 scale div. = 1.28×10^{-9} amp.), for a MORSE dash when the tone was just audible in the most sensitive telephones. In regard to a magnetic detector for measuring purposes see R. ARN , *Lum.  l.* (2), **6**, 344, 1909.

⁸⁰ That is,

$$\begin{aligned} \mathcal{E}_{i_1} &= -Ls_{12} \frac{dI_2}{dt}; & \mathcal{E}_{i_2} &= -Ls_{21} \frac{dI_1}{dt} \\ \mathcal{E}_{o_1} &= RI_2; & \mathcal{E}_{o_2} &= RI_1 \end{aligned}$$

The differential equations for two circuits carrying *quasi-stationary* current and which are *magnetically* coupled are

$$\left. \begin{aligned} \frac{I_1}{C_1} + R_1 \frac{dI_1}{dt} + L_1 \frac{d^2 I_1}{dt^2} + Ls_{12} \frac{d^2 I_2}{dt^2} &= 0 \\ \frac{I_2}{C_2} + R_2 \frac{dI_2}{dt} + L_2 \frac{d^2 I_2}{dt^2} + Ls_{21} \frac{d^2 I_1}{dt^2} &= 0 \end{aligned} \right\} \quad (1)$$

If the circuits have pure *conductive* coupling,

$$\left. \begin{aligned} \frac{I_1}{C_1} + R_1 \frac{dI_1}{dt} + R \frac{dI_2}{dt} + L_1 \frac{d^2 I_1}{dt^2} &= 0 \\ \frac{I_2}{C_2} + R_2 \frac{dI_2}{dt} + R \frac{dI_1}{dt} + L_2 \frac{d^2 I_2}{dt^2} &= 0 \end{aligned} \right\} \quad (2)$$

in which R_1 and R_2 are the total resistances of the primary and secondary circuits respectively, R , the resistance common to both circuits.

If the circuits have pure electric coupling,

$$\left. \begin{aligned} \frac{I_1}{C_1} + \frac{I_2}{C} + R_1 \frac{dI_1}{dt} + L_1 \frac{d^2 I_1}{dt^2} &= 0 \\ \frac{I_2}{C_2} + \frac{I_1}{C} + R_2 \frac{dI_2}{dt} + L_2 \frac{d^2 I_2}{dt^2} &= 0 \end{aligned} \right\} \quad (3)$$

in which C_1 and C_2 are the total effective capacities of the primary and secondary circuits respectively, C the capacity common to both circuits.

If the current is *not quasi-stationary* in either of the two circuits, say in the secondary, the energy equation for the case of magnetic coupling is found as follows:

Assume that the current amplitude may be considered as uniform along the entire coupling ($x = k$) in the secondary circuit as well as the primary. Let $L_{s_{12}}$ and $L_{s_{21}}$ be the coefficients of mutual induction for the case of quasi-stationary currents in both circuits and let

$$\left. \begin{aligned} L_{12} &= L_{s_{12}} \cdot f(x)[x = k] \\ L_{21} &= L_{s_{21}} \cdot f(x)[x = k] \end{aligned} \right\} \quad (\text{see Note 40})$$

Then the energy transferred per second from the secondary to the primary circuit is equal to

$$L_{12} \cdot I_1 \frac{d|I_2}{dt}$$

and the energy transferred per second from the primary to the secondary circuit is

$$L_{21} \cdot |I_2| \frac{dI_1}{dt}$$

The differential equations therefore take the form

$$\begin{aligned} \frac{I_1}{C_1} + R_1 \frac{dI_1}{dt} + L_1 \frac{d^2 I_1}{dt^2} + L_{12} \frac{d^2 |I_2|}{dt^2} &= 0 \\ \frac{|I_2|}{C_2} + R_2 \frac{d|I_2|}{dt} + L_2 \frac{d^2 |I_2|}{dt^2} + L_{21} \frac{dI_1}{dt} &= 0 \end{aligned}$$

(Symbols C_2 , R_2 and L_2 are used just as in Note ²⁹), which are the same as for magnetic coupling of quasi-stationary currents (equation 1).

If two different oscillations occur in each circuit [Art. 58], it must not be forgotten that the current and potential distribution [$f(x)$ and $\varphi(x)$] and therefore the values of R , C and L are different for the two oscillations (A. SLABY). So far as the author knows no theory (mathematical) which takes this fact into account has been worked out to date; however, it is not probable that the results are much different than those obtained with the present theory.

⁸¹ J. V. GETTLER (Wien. Ber., **104**, II, 169 *et seq.*, 1895; Wied. Ann., **55**, 513, 1895) and J. ZENNECK, Phys. Zeitschr., **4**, 656, 1903.

⁸² Thanks are due to the TELEFUNKEN Co. of Berlin for this illustration.

⁸³ See *EMS*, 634 *et seq.*

⁸⁴ V. BJERKNES, Wied Ann., **44**, 74, 1891; **55**, 121, 1895.

⁸⁵ These relations hold for primary circuits containing a spark gap only if the amplitude curve is an exponential curve.

Nor do they hold in the case $d_1 = d_2 = d$. In this case, the oscillation in the secondary circuit is of the form $I = I_0 t e^{-\frac{d}{T} t} \sin \omega t$.

⁸⁶ M. WIEN, Jahrb., **1**, 462, 1908; Ann. Phys., **25**, 625, 1908.

⁸⁷ This is true only if there is no quenching action [Art. 62 *et seq.*] and even if this is

not the case, the amplitude of one of the oscillations can be zero. Whether or not this occurs depends upon the initial conditions (see ⁹¹).

- ⁸⁸ H. DIESSELHORST, Ber. deutsch. physik. Ges., **5**, 320, 1907; **6**, 306, 1908; *ETZ*, **1908**, 703. H. RAU, *Jahrb.*, **4**, 52, 1910. (RAU, in order to obtain spark photographs inserted a small gap in the secondary circuit also.)
- ⁸⁹ P. DRUDE, *Ann. Phys.*, **13**, 512 *et seq.*, 1904. For the theory of coupled circuits also see: B. MACKÛ, *Jahrb.*, **3**, 104 *et seq.*, 329 *et seq.*, 1910. A. KALÄHNE, *Jahrb.*, **4**, 357 *et seq.*, 1911. The disadvantage of the approximation methods of L. COHEN (*Jahrb.*, **2**, 448 *et seq.*, 1909) and J. S. STONE (*Lum. él.*, **12**, 435, 1910; *ETZ*, **33**, 111, 1911) is that the degree of accuracy of their results cannot be predetermined.
- ⁹⁰ C. FISCHER, *Ann. Phys.*, **22**, 265, 1907. M. WIEN, *Phys. Zeitschr.*, **7**, 871, 1906, **8**, 10 *et seq.*, 1907; *ETZ*, **1906**, 839. Also see J. KAISER, *Phys. Zeitschr.*, **10**, 886, 1909. C. FISCHER, *Phys. Zeitschr.*, **11**, 420, 1910. W. BIERLEIN, *Jahrb.*, **6**, 29, 1912. E. TALSCH, *Jahrb.*, **6**, 35, 1912.
- ⁹¹ What follows holds true only under the following initial conditions: when $t = 0$

$$V_1 = V_{10}, I_1 = 0; V_2 = 0; I_2 = 0$$

Under other conditions in fact it may happen that only *one* oscillation occurs. (A. SLABY, *ETZ*, **1904**, 1086, M. WIEN, *ETZ*, **1906**, 837.) The relations given in *a* and *b* are easily deduced from the work of P. DRUDE.⁸⁹ The vector diagram holds for the beginning (initial conditions) of the oscillations. Afterward it applies only to currents of constant frequency.

- ^{91a} J. ZENNECK, *Phys. Zeitschr.*, **6**, 198, 1905.
- ⁹² M. WIEN, *Jahrb.*, **1**, 469, 1908; **4**, 135, 1911; *Ann. Phys.*, **25**, 625, 1908; *Phys. Zeitschr.*, **11**, 76, 311, 1910.
- ⁹³ H. BOAS, *Jahrb.*, **5**, 563, 1912.
- ⁹⁴ A. ESPINOSAS DE LOS MONTEROS, *Jahrb.*, **1**, 480, 1908. The hydrogen spark gaps have been very carefully studied by B. GLATZEL. Summary of his articles in *Jahrb.*, **4**, 400, 1911. For special methods of connection employing two or more spark gaps in series see *Jahrb.*, **5**, 437, 1912; *EL*, **68**, 428 *et seq.*, 1911.
- ⁹⁵ R. RENDAHL, *Phys. Zeitschr.*, **9**, 203, 1908. B. GLATZEL, Ber. der deutschen physik. Ges., **6**, 54, 1908; *Jahrb.*, **2**, 65, 1908. A. ESPINOSA DE LOS MONTEROS.⁹⁴
- ^{95a} The coupling, however, must not be so loose that the duration of half of a pulsation occupies considerable time during which the oscillations have an appreciable amplitude. For, as the two coupling waves exist during the first half pulsation, the object of the quenched gap would not be completely secured.
- ⁹⁶ Regarding the relation of the spark frequency to the effectiveness of the quenching action, see H. ROHMANN, *Phys. Zeitschr.*, **12**, 649, 1911.
- ⁹⁷ B. MACKÛ, *Ann. Phys.*, **34**, 941, 1911.
- ^{97a} S. SUBKIS, *Jahrb.*, **5**, 507, 545, 1912; Diss. Braunschweig, 1911. Also see C. FISCHER.¹¹⁵
- ⁹⁸ G. GLAGE, Experimental investigations with the resonance inductor. Diss. Strassburg, 1907. H. BOAS, *Jahrb.*, **3**, 432, 607, 1910. K. ROTTGARDT, *Phys. Zeitschr.*, **12**, 652, 1911. S. KIMURA, *Jahrb.*, **5**, 222, 1911, **6**, 459, 1912. For the theory, see G. SEIBT, *ETZ*, **1904**, 276. G. BENISCHKE, *ETZ*, **28**, 2d issue, 1907. J. BETHENOD, *Jahrb.*, **1**, 534, 1908. Historical: P. BRENOT, *Lum. él.* (2), **11**, 167, 1910.

- ⁹⁹ Integral of the equation for the discharge of condenser circuits

$$\frac{I}{C} + R \frac{\delta I}{\delta t} + L \frac{\delta^2 I}{\delta t^2} = 0$$

in the case of *aperiodic* discharge.

¹⁰⁰ Integral of the differential equation

$$\frac{I}{C} + R \frac{\delta I}{\delta t} = 0$$

¹⁰¹ More detailed treatment in *EMS*, Chap. XIII and XIV.

¹⁰² The wave-length, λ , obtained in this way, is really too small by an amount $\Delta\lambda$, which is given by

$$\frac{\Delta\lambda}{\lambda} = \frac{d_1(d_1 + d_2)}{8\pi^2}$$

(B. MACKÛ, *Jahrb.*, **2**, 251, 1909). In regard to a zero method for determining the frequency, see G. SEIBT, *Jahrb.*, **5**, 407, 1912.

¹⁰³ E. DORN, *Ann. Phys.*, **20**, 127, 1906.

¹⁰⁴ See, *e.g.*, the corresponding paragraphs in F. KOHLRAUSCH, *Lehrbuch der praktischen Physik*.

¹⁰⁵ Comparative tests by different methods: H. DIESSELHORST.⁸ Also see A. CAMPBELL, *El.* **64**, 612 *et seq.*, 1912.

¹⁰⁶ See, *e.g.*, *EMS*, p. 711.

¹⁰⁷ More accurate discussion of the resonance method and the necessary corrections: B. MACKÛ.¹⁰² Also see M. K. GROBER, *Phys. Zeitschr.*, **12**, 121, 1911.

¹⁰⁸ H. BRANDES, *Ann. Phys.*, **22**, 645, 1907. Graphic method by F. EGER, *Diss. Greifswald*, 1908.

¹⁰⁹ L. KANN, *Jahrb.*, **4**, 297, 1911; *Phys. Zeitschr.*, **11**, 503, 1910. The BRANDES method is also the basis of an arrangement of P. LUDEWIG (*Phys. Zeitschr.*, **12**, 763, 1911; *Jahrb.*, **5**, 390, 1912), which gives a direct indication of the decrement.

¹¹⁰ See G. JONAS, *Diss. Strassburg*, 1907.

¹¹¹ H. RIEGGER.⁷

¹¹² B. MACKÛ, *Ann. Phys.*, **34**, 941, 1911.

¹¹³ M. WIEN⁸⁶ and *Phys. Zeitschr.*, **9**, 537, 1908. B. MACKÛ¹⁰² and *Phys. Zeitschr.*, **9**, 437, 646, 1908.

¹¹⁴ S. LOEWE, *Jahrb.*, **6**, 325, 1912.

¹¹⁵ Concerning the POULSEN arc for measuring: RAUSCH VON TRAUBENBERG and B. MONASCH, *Phys. Zeitschr.*, **8**, 925, 1907; **9**, 251, 1908. C. FISCHER, *Ann. Phys.*, **28**, 57, 1909; **32**, 979, 1910. F. KIEBITZ, *Ber. physik. Ges.*, **12**, 99, 1910; *Jahrb.*, **2**, 357 *et seq.*, 1909. *PHYS. TECHN. REICHSANSTALT: Zeitschr. f. Instrumentenkunde*, **28**, 148, 1908. R. LINDEMANN, *Ber. physik. Ges.*, **11**, 28, 1909. K. VOLLMER, *Jahrb.*, **3**, 123, 1909. According to G. SZIVESSY (*Jahrb.*, **3**, 250 *et seq.*, 1910) an arc in bisulphide of carbon vapor gives very steady oscillations.

¹¹⁶ In regard to precautions for the use of these spark gaps for measuring purposes, see S. LOEWE.¹¹⁴

¹¹⁷ H. TH. SIMON, *Phys. Zeitschr.*, **4**, 737, 1903. G. W. PIERCE, *Phys. Zeitschr.*, **5**, 426, 1904.

¹¹⁸ W. EICKHOFF, *Phys. Zeitschr.* **8**, 923, 1907. According to W. F. ZORN¹⁵ the point on copper electrodes causes an increase in the spark damping. J. A. FLEMING and H. W. RICHARDSON (*El.*, **63**, 175, 1909) recommend air blowers to make the discharges more regular. This result, however, is not always accomplished (*i.e.*, with all types of gaps) by a blower.

¹¹⁹ Another procedure is to make the coupling looser gradually until the value, which is obtained from the resonance curve in accordance with Art. 74 remains constant. The theoretical requirement for this condition is: $\pi^2 K^2 \ll d_1 d_2$.⁸⁶ Also see R. LINDEMANN's¹¹⁵ method.

¹²⁰ M. WIEN, *Phys. Zeitschr.*, **8**, 764, 1907: with $d_1 = 0.11$, $d_2 = 0.015$ and $K = 0.014$ the error becomes 30 per cent.

- ¹²¹ Complete treatment in the book, *Die Frequenzmesser und Dämpfungsmesser der Strahlentelegraphie*, by E. NESPER, Leipzig, 1907.
- ¹²² *E.g.*, *El.*, **68**, 249 *et seq.*, 1911.
- ¹²³ THOR. G. THÖRNBLAD, *Jahrb.*, **4**, 97 *et seq.*, 109 *et seq.*, 217 *et seq.*, 1911.
- ¹²⁴ E. NESPER, *Jahrb.*, **1**, 112, 1907.
- ¹²⁵ J. A. FLEMING, *El.*, **58**, 495 *et seq.*, 536 *et seq.*, 1907.
- ¹²⁶ *Lum. él.*, **9**, 391, 1910.
- ¹²⁷ *Ann. Phys.*, **8**, 211, 1902.
- ¹²⁸ R. HIRSCH, *Jahrb.*, **4**, 250, 1911.
- ¹²⁹ L. MANDLESTAM and N. PAPALEXI, *Jahrb.*, **4**, 605, 1911. The high degree of accuracy of the method for determining frequency is well shown in the article by H. ROHMANN, *Diss. Strassburg*, 1911; *Ann. Phys.*, **34**, 979, 1912.
- ¹³⁰ The dynamometer effect is $= \frac{1}{t} \int_0^t I_1 I_2 dt$
- ¹³¹ Another method for determining the dynamometer effect by means of a differential air thermometer by L. KANN¹⁰⁹ and L. ISAKOW, *Phys. Zeitschr.*, **12**, 1224, 1911.
- ¹³² The e.m.f. induced in the ring is displaced 90° with respect to I'_2 , and I_3 is in turn displaced 90° from this e.m.f.
- ¹³³ On the assumption that the current curve is the same in both cases [see Art. 11*e*, 2].
- ¹³⁴ W. EICKHOFF, *Phys. Zeitschr.*, **8**, 564, 1907. A. JOLLOS (*Diss. Strassburg*, 1907) was probably the first to show that an unsymmetrical resonance curve was the result of condenser brush discharge. Concerning the brush discharge of condensers also see M. WIEN¹⁷ and L. W. AUSTIN.²¹
- ¹³⁵ From C. FISCHER.⁹⁰
- ¹³⁶ This method was developed at the suggestion of the author by C. FISCHER, *Ann. Phys.*, **19**, 182, 1906.
- ¹³⁷ The use of damping meter of P. LUDEWIG for determining the degree of coupling (*Phys. Zeitschr.*, **13**, 450, 1912) is also based upon this relation.
- ¹³⁸ B. MACKŮ, *Jahrb.*, **3**, 580 *et seq.*, 1910.
- ¹³⁹ TELEFUNKEN Co., *El.*, **68**, 171, 1911.
- ¹⁴⁰ Experiments at the physik. Inst. Danzig-Langfuhr.
- ¹⁴¹ Spark photographs can also be used instead of the resonance curves. H. RAU.⁸⁸
- ¹⁴² R. A. FESSENDEN, *ETZ*, **1906**, 690.
- ¹⁴³ Antennæ with increased end capacity were one of the first forms of antennæ used by MARCONI and LODGE. Their fundamental advantages are given by A. BLONDEL.⁴¹
- ¹⁴⁴ Additional details regarding the TELEFUNKEN Co's antennæ: SIEWERT, *ETZ*, **1906**, 965. R. SOLFF, *ETZ*, **1906**, p. 875 *et seq.* COUNT ARCO, A. E. G. lectures, lecture of Dec. 9, 1911. H. BREDOW, *Jahrb. der Schiffbau-technischen Ges.*, **1912**, 105 *et seq.* Various articles in the TELEFUNKENZEITUNG.
- ¹⁴⁵ O. LODGE and A. MUIRHEAD, *El.*, **51**, 1036, 1903. See *El.*, **62**, 170, 1908.
- ¹⁴⁶ COUNT ARCO.¹⁴⁴
- ¹⁴⁷ L. W. AUSTIN, *Bullet. Bur. Stands*, **7**, 315 *et seq.*, 1911.
- ¹⁴⁸ Various constructions for masts: *Jahrb.*, **3**, 203, 521, 1910; **4**, 309, 652, 1911. *El.*, **68**, 213, 1911.
- ¹⁴⁹ O. LODGE and A. MUIRHEAD at times erected their counterpoise several meters above the ground (see *Jahrb.*, **3**, 1, 1909).
- ¹⁵⁰ W. BURSTYN, *ETZ*, **1906**, 1117. F. KIEBITZ, *Ann. Phys.*, **32**, 961, 1910. M. REICH, *Phys. Zeitschr.*, **13**, 228 *et seq.*, 1912; *Jahrb.*, **5**, 176 *et seq.*, 253 *et seq.*, 1911. H. TRUE, *Jahrb.*, **5**, 125 *et seq.*, 1911. P. BARRECA, *Jahrb.*, **5**, 285 *et seq.*, 1912.

- ¹⁵¹ Regarding radio-apparatus for airships and tests therewith see *Jahrb.*, **3**, 315, 434, 1910, **4**, 227, 1911, **6**, 70, 1912. FERRIÉ, *Lum. él.* **12**, 99 *et seq.*, 1910. TELEFUNKENZEITUNG, **1**, 66, 1911. K. SOLFF, *Jahrb.*, **3**, 392 *et seq.*, 1910. K. LUBOWSKY, *ETZ*, **32**, 1265, 1911. M. DIECKMANN, *Jahrb.*, **6**, 51, 1912. "Luftfahrt und Wissenschaft" No. 2, 1912. P. LUDEWIG, *Jahrb.*, **6**, 10, 1912. H. MOSLER, *Jahrb.*, **6**, 44, 1912.
- ¹⁵² Regarding oscillations induced in all metal parts near quenched gap circuits, see S. LOEWE.¹¹⁴
- ¹⁵³ According to DR. MEISSNER, however, the dangerous effect upon the ropes and the bag of the balloon is greatly increased when large current effect is used.
- ¹⁵⁴ Tests of the accuracy of the methods given in Art. 97: A. ESAU, *Phys. Zeitschr.* **13**, 658, 1912.
- ¹⁵⁵ C. FISCHER, *Ann. Phys.*, **32**, 979 *et seq.*, 1910.
- ¹⁵⁶ Concerning the increase in antenna capacity due to ice, rain, snow, etc., and the relation between antenna damping and weather conditions see A. ESAU, *Phys. Zeitschr.*, **13**, 721, 1912.
- ¹⁵⁷ COUNT ARCO, *ETZ*, **1910**, 508.
- ¹⁵⁸ See, *e.g.*, B. C. TISSOT,⁷⁴ p. 139, 148 *et seq.*
- ¹⁵⁹ Regarding antenna insulators used by the TELEFUNKEN CO., see H. BREDOW.¹⁴⁴ For methods of reducing brush discharge see *Jahrb.*, **4**, 441, 1911. H. LANGE, *Jahrb.*, **4**, 442, 1911.
- ¹⁶⁰ COUNT ARCO, *Jahrb.*, **2**, 551 *et seq.*, 1909.
- ¹⁶¹ Regarding total antenna resistance and its determination, see C. FISCHER, *Phys. Zeitschr.*, **12**, 295, 1911. L. W. AUSTIN, *Phys. Zeitschr.*, **12**, 924, 1911; *Jahrb.*, **5**, 574 *et seq.*, 1912. There seems to be a relation between the total antenna resistance and the wave-length of the oscillation, such that the total resistance first decreases and then again increases in a straight line (uniformly) as the wave-length is increased. The decrease at first is probably due to the decrease in R_{Σ} accompanying the increase in wave-length, the subsequent increase in total resistance must be due to an increase in the resistance of the earth, at any rate it varies with the amount of moisture in the ground.
- ¹⁶² J. ERSKINE-MURRAY, *Jahrb.*, **5**, 499, 1912. M. REICH, *Phys. Zeitschr.*, **13**, 228 *et seq.*, 1912.
- ¹⁶³ $\mathcal{E} = \int_0^h E_x dx$, where dx is an element of the antenna, E_x the component of the electric field strength along this element and h the length of the antenna.
- ¹⁶⁴ *Bullet. Soc. d'encouragement p. l'industrie rationale*, **3**, 1632, 1898.
- ¹⁶⁵ F. BRAUN, D.R.P. No. 109378 (1899), *Electrician*, **52**, 19, 1904; *Phys. Zeitschr.*, **5**, 193, 1904.
- ¹⁶⁶ *L'Electricien*, **42**, 107, 1911.
- ¹⁶⁷ Literature of compressed air spark gaps, F. JERVIS-SMITH, *El.*, **63**, 720, 1909.
- ¹⁶⁸ G. EICHHORN, D.R.P., 157056 (1903). The modification (Fig. 218) of his original arrangement is due to P. PICHON (TELEFUNKEN Co.).
- ¹⁶⁹ B. GLATZEL, *Phys. Zeitschr.*, **11**, 893, 1910.
- ¹⁷⁰ S. EISENSTEIN, *El.*, **65**, 848, 1910.
- ^{170a} R. C. GALLETI (*El.*, **66**, 570, 1911; *ETZ*, **32**, 597, 1911, D.R.P., 245358).
- ¹⁷¹ Other methods of connection by G. SEIBT, D.R.P., 241114 (1909). B. MACKÛ, *El.*, **68**, 429, 1911.
- ¹⁷² *Jahrb.*, **2**, 229, 1909.
- ¹⁷³ COUNT ARCO,¹⁶⁰ B. GLATZEL, *Jahrb.*, **2**, 90, 1908.
- ¹⁷⁴ A two plate spark gap was probably first proposed by T. B. KINRAIDE, U. S. Patent 623316 (1898), D.R.P., 108924 (1899).

- ¹⁷⁵ EL., **63**, 174 *et seq.*, 374 *et seq.*, 1909; **64**, 153 *et seq.*, 1909. Tests made by W. H. ECCLES and A. J. MACKAWER, EL., **64**, 386, 1909; Jahrb., **4**, 294, 1911.
- ¹⁷⁶ COUNT ARCO,¹⁶⁰ Jahrb., **4**, 79 *et seq.*, 1910, *ETZ*, **31**, 506 *et seq.*, 1910.
- ¹⁷⁷ O. SCHELLER, Jahrb., **5**, 243, 1911.
- ¹⁷⁸ W. PEUCKERT, Jahrb., **3**, 199, 1909. A. WASMUS.⁷¹ L. H. WALTER, EL., **64**, 550 1910.
- ¹⁷⁹ Regarding other stations of the TELEFUNKEN CO., see COUNT ARCO,¹⁷⁶ H. BREDOW.¹⁴⁴
- ¹⁸⁰ F. G. LORING, EL., **67**, 27, 1911.
- ¹⁸¹ H. RAU.⁸⁸
- ¹⁸² See C. MÜLLER⁵⁶ and then also M. TOEPLER.⁶⁴
- ¹⁸³ Such meters were built, though for quite other purposes, by Siemens and Halske, Berlin, at the suggestion of the author.
- ¹⁸⁴ See, *e.g.*, G. BRION, Leitfaden zum elektrotechnischen Praktikum, p. 102 (B. G. TEUBNER, 1910). The Dolezaleck electrometer can also be used for power measurements; *e.g.*, see M. REICH.¹⁵⁰
- ¹⁸⁵ W. BURSTYN, Jahrb., **6**, 217, 1912, proposes methods for making and breaking the circuit of the field excitation current.
- ¹⁸⁶ See P. O. PEDERSEN, Jahrb., **4**, 524, 1911. Regarding the high-speed telegraph apparatus used by POULSEN, see *ETZ*, **32**, 1164, 1911.
- ¹⁸⁷ EL., **60**, 546, 883, 1908. Other spark gaps having smooth rotating electrodes: S. EISENSTEIN, Jahrb., **5**, 245, 1911. W. BURSTYN, Jahrb., **6**, 212, 1912.
- ¹⁸⁸ L'Electricien, **42**, 107, 1911.
- ¹⁸⁹ EL., **65**, 847, 1910. A similar arrangement by G. FERRIÉ, EL., **65**, 135, 1910.
- ¹⁹⁰ EL., **64**, 512 *et seq.*, 1910. This gap is used by the Soc. franç. radioélectrique.
- ¹⁹¹ G. MARCONI, EL., **67**, 532, 1911; EL. World, **59**, 887, 1912; Jahrb., **6**, 438, 1913; also see E. NESPER, Helios, **18**, 429, 1912. As MARCONI employs relatively loose coupling (5 per cent.), the duration of half a pulsation and hence of the time during which there are two coupling waves present in the antenna, is rather long. Consequently they are evident in the resonance curve. See^{95a} and Art. 90a.
- ¹⁹² See, *e.g.*, C. C. F. MONCKTON, EL., **56**, 514, 1906.
- ¹⁹³ W. H. ECCLES and A. J. MACKOWER (Jahrb., **4**, 253, 1911; EL., **65**, 1014, 1910) find a considerably lower efficiency from their measurements, which latter, however, are open to criticism.
- ¹⁹⁴ W. DUDELL, Phil. Mag. (6), **9**, 299, 1905; Proc. Royal Inst., May 17, 1912. Also see Jahrb., **4**, 202, 1911.
- ¹⁹⁵ E. F. W. ALEXANDERSON, Trans. Amer. Inst. El. Eng., **28**, I, 399 *et seq.*, 1910.
- ¹⁹⁶ R. A. FESSENDEN, D. R. P., 228,365, 1908.
- ¹⁹⁷ R. GOLDSCHMIDT, *ETZ*, **32**, 54, 1911; Jahrb., **4**, 341 *et seq.*, 1911.
- ¹⁹⁸ We may either conceive the alternating field of frequency N' as made up of two rotating fields of opposite direction or we may proceed on the basis that the magnetic flux passing through R must be of the form
- $$A \sin (2\pi N \cdot t + \alpha) \cos (2\pi N' \cdot t + \alpha')$$
- $$= \frac{A}{2} \left\{ \sin [2\pi(N + N')t + (\alpha + \alpha')] + \sin [2\pi(N - N')t + (\alpha - \alpha')] \right\}$$
- For the theory of the GOLDSCHMIDT machine see E. RUSCH, Jahrb., **4**, 348 *et seq.*, 1911. B. MACKÛ, Jahrb., **5**, 5, 1911. See Note.³⁴⁴
- ^{198a} In the commercial form, condensers C_1 and C_3 are omitted.
- ¹⁹⁹ Very little has so far been published regarding the new high frequency generator of COUNT ARCO, which was exhibited at the international convention in London in 1912. See Jahrb., **5**, 529, 1912. TELEFUNKENZEITUNG, Vol. **2**, No. 7, p. 18. In regard to the generation of undamped oscillations by means of a series ma-

- chine with a condenser connected in parallel see F. FITZGERALD (*Eclair. él.*, **18**, 386, 1892). O. M. CORBINO (*Phys. Zeitschr.*, **8**, 924, 1907; **9**, 195, 704, 1908; *Electrician*, **61**, 56, 1908). R. RÜDENBERG (*Phys. Zeitschr.*, **8**, 668, 1907; **9**, 556, 1908). H. BARKHAUSEN, *Das Problem der Schwingungserzeugung*. Diss. Göttingen, 1907, p. 37. It is impossible to conclude from the results obtained to date whether it will ever be possible to produce undamped oscillations for wireless telegraphy by this method in a practical and useful way.
- ²⁰⁰ EL. THOMSON, U. S. Pat., July 18, 1892 (quoted in *El. Review*, **60**, 328, 1907); U. S. Pat. No. 500630, July 4, 1893. N. TESLA in MARTIN'S "Nichola Teslas Untersuchungen über Mehrphasenströme." Halle, 1895. FESSENDEN claims to have made his first attempts in this direction in 1899.
- ²⁰¹ W. DUDELL, *Electrician*, **46**, 269, 310, 1900.
- ²⁰² J. WERTHEIM-SALOMONSON, *Electrician*, **52**, 126, 1904. *Eclairage électr.*, **38**, 144, 1904. $N = 400,000$ cyc. per sec.
- ²⁰³ V. POULSEN, Danish Pat. 5590 (Sept. 9, 1902), D.R.P. 162945 (July 12, 1903).
- ²⁰⁴ For further details see the TELEFUNKEN Co.'s pamphlet describing their standard radio-telephone station. C. SCHAPIRA on the efficiency of the high frequency arc lamp with subdivided arc. Diss. Charlottenburg, 1908 and *Jahrb.*, **2**, 54 *et seq.*, 1908.
- ²⁰⁵ P. BRENOT states in *Lum. él.* (2), **11**, 170, 1910 (also see *Lum. él.* (2), **11**, 197, 1910) that A. BLONDEL employs two plates in petroleum as electrodes and impresses about 2000 volts across the arc. It is claimed that this gives greater regularity than the POULSEN method but does not secure high frequencies so easily. The author does not know whether the BLONDEL method, which is very similar to the PEUCKERT method, has ever been used in practice. According to *Jahrb.*, **4**, 522, 1911, F. JACOVIELLO employs metallic electrodes, potentials of 40,000 to 80,000 volts and impinges a stream of gas upon the arc, approximately in the direction of the length of the arc. Whether a quenched gap or undamped oscillations were used is not clear from what has been published.
- ²⁰⁶ From W. DUDELL, *Proc. Royal Inst.*, May 17, 1912.
- ²⁰⁷ *Jahrb.*, **1**, 307, 1908.
- ²⁰⁸ Data on POULSEN stations:
- a. LYNGBY and CULLERCOATS, *Jahrb.*, **1**, 154 *et seq.*, 1907; *Electrician*, **60**, 355 *et seq.*, 1907.
 - b. KNOCKROE, *Jahrb.*, **1**, 430, 1908; *ETZ*, **1908**, 15.
- ²⁰⁹ According to the C. LORENZ Co., this method of connection originated with W. HAHNEMANN and O. SCHELLER.
- ²¹⁰ P. O. PEDERSEN, *El.*, **60**, 547, 1908. C. LORENZ, *Jahrb.*, **4**, 333, 1911.
- ²¹¹ H. REIN, *Jahrb.*, **4**, 196, 1911 and "Der radiotelegraphische Gleichstromtensender," *Langensalza*, 1912.
- ²¹² A large number of investigations of these phenomena have been made during recent years, the principal ones being the following:
- a. O. M. CORBINO, *Atti. Assoc. Elettrotecnica Ital.*, Oct., 1903 (mentioned in *Phys. Zeitschr.*, **9**, 197, 1908).
 - b. A. BLONDEL, *Ecl. El.*, **44**, 41 *et seq.*, 81 *et seq.*, 1905. BLONDEL was the first to distinguish the different kinds of oscillations.
 - c. H. BARKHAUSEN, *Jahrb.*, **1**, 234 *et seq.*, 1907.
 - d. H. TH. SIMON: Various articles, in part jointly with M. REICH. The articles are quoted in the general discussion by H. TH. SIMON in *Jahrb.*, **1**, 16, 1907.
 - e. W. DUDELL, *Electrician*, **46**, 268, 310, 1900.
 - f. G. GRANQVIST, *Nov. Act. Reg. Soc. Scient. Upsaliensis* (4), **1**, No. 5.
 - g. E. RIECKE, *Göttinger Nachr. Math.-phys. Kl.*, **1907**, 253.

h. K. H. WAGNER, "Der Lichtbogen als Wechselstromerzeuger." Leipzig, 1910.

i. For a comprehensive survey of this subject see H. BARKHAUSEN, "Das Problem der Schwingungserzeugung." Diss. Göttingen, 1907. In that article one question, namely, under what conditions the various kinds of oscillations are stable, which has not been considered in this book, is discussed in detail. In other respects the treatment of this subject in what follows, is very similar to that given by BARKHAUSEN.

²¹³ This is really a portion of a sine curve. See, e.g., *EMS*, p. 547.

²¹⁴ The charging curve is determined by the equation

$$V = V_0 \left[1 - e^{-\frac{1}{R_0 C} \cdot t} \right]$$

in which V_0 = dynamo voltage, C = capacity of condenser.

²¹⁵ G. W. NASMYTH (Jahrb., **5**, 269 *et seq.*, 367 *et seq.*, 1912) has given formulæ for the frequency of oscillations generated by the arc method. These formulæ however have been discussed by K. VOLLMER¹¹⁵ and P. O. PEDERSEN (Jahrb., **5**, 496, 1912).

²¹⁶ Regarding the function of the magnetic blowout see H. RAUSCH VON TRAUBENBERG, *ETZ*, **28**, 559, 1907. H. TH. SIMON,²⁰⁸ p. 65. H. BARKHAUSEN,²⁰⁸ p. 256. K. BIRKELAND (Jahrb., **2**, 137, 1908) suggests a radial magnetic field for producing a rotating arc.

²¹⁷ See H. BARKHAUSEN, Jahrb., **2**, 40, 1909.

²¹⁸ In Arts. **138**, **139**, **140** and **142** it is assumed that (1) the oscillations are undamped, (2) the atmosphere is an absolute non-conductor; furthermore in Arts. **138** to **140** it is taken for granted that the assumed conductivity holds for the entire portion of the earth which comes into consideration. As to the first assumption, L. W. AUSTIN (Jahrb., **5**, 524, 1912) was unable to find any difference between undamped waves and waves having a decrement of 0.15 at a distance of 30 miles.

²¹⁹ As early as 1898, A. BLONDEL (Compt. rend. Assoc. franç. Avancement des sciences. Congrès de Nantes, 1898, p. 212 *et seq.*) pointed out in conjunction with a remark of POINCARÉ that the action of the earth in a grounded transmitter could be replaced by that of an image of the transmitter, *i.e.*, that a grounded transmitter can properly be conceived as one-half of a HERTZ lineal oscillator.

²²⁰ A comparison of the two limiting cases, the lineal transmitter (Figs. 27-30) on one hand with transmitter having uniform current amplitude throughout, as shown for example in *EMS*, Figs. 613-621.

²²¹ J. ZENNECK (Ann. Phys., **23**, 846, 1907). Previous to this, K. ULLER (Diss. Rostock, 1903) had already investigated the action of the waves under the assumption that they are entirely surface waves and that the earth's surface possesses a high degree of conductivity.

²²² A. SOMMERFELD, Ann. Phys., **28**, 665, 1909; Jahrb., **4**, 158, 1910.

²²³ Regarding the conductivity of sea water, earths and rocks, see H. SCHMIDT, Jahrb., **4**, 636 *et seq.*, 1911. K. ULLER, Jahrb., **4**, 638, 1911. H. LOEWY, Ann. Phys., **36**, 125 *et seq.*, 1911 and discussion thereof by J. A. FLEMING, Jahrb., **5**, 515, 1912.

²²⁴ This conception that the waves of radio-telegraphy are of the nature of surface waves was probably first presented by A. BLONDEL²¹⁹ and by E. LECHER (Phys. Zeitschr., **3**, 273, 1901-1902). Also see K. ULLER, "Die Mitwirkung der Erde und die Bedeutung der Erdung in der drahtlosen Telegraphie, Jahrb., **2**, 8, 1908.

²²⁵ P. EPSTEIN, Jahrb., **4**, 176 *et seq.*, 1910.

- ²²⁶ H. POINCARÉ, *Jahrb.*, **3**, 445, 1910. J. W. NICHOLSON, Review of his articles, *Jahrb.*, **4**, 20, 1910; *Phil. Mag.*, **21**, 281, 1911. H. W. MARCH (*Ann. Phys.*, **37**, 29, 1912. Note corrections in subsequent issue of *Ann. Phys.*). H. MACDONALD, *Phys. Zeitschr.*, **10**, 771, 1909.
- ²²⁷ H. B. JACKSON, *Proc. Royal Soc.*, **70**, 254 *et seq.*, 1902.
- ²²⁸ W. DUDDELL and J. E. TAYLOR, *Electrician*, **55**, 260, 1905. C. TISSOT, *Electrician*, **56**, 848, 1906.
- ²²⁹ F. HACK, *Ann. Phys.*, **27**, 43, 1908. The assumptions are the same as in.²²¹
- ²³⁰ *Electrician*, **55**, 409, 1905.
- ²³¹ F. KIEBITZ, *Verh. physik. Ges.*, **13**, 876 *et seq.*, 1911.
- ²³² A reflection of this kind has been demonstrated in laboratory experiments with very short waves: F. ERB, *Diss. Braunschweig*, 1912. Data on observations in practice: P. SCHWARZHaupt, *ETZ*, **31**, 113, 1911.
- ²³³ See L. ZEHNDER, *ETZ*, **32**, 1101, 1911.
- ²³⁴ In regard to the influence of the weather upon the antenna oscillations see A. ESAU,¹⁵⁶ O. GÜLDENPFENNIG, *Jahrb.*, **5**, 73, 1911. WILDMANN (see ERSKINE-MURRAY¹) made systematic observations for over a year on the effect of the weather upon the communication between two stations.
- ²³⁵ H. EBERT (*Jahrb.*, **4**, 160, 1911) found the conductivity of the air at a height of 2500 m., in bright sunlight and in a downward current of air, to be twenty-three times as great as the conductivity just over the earth's surface. Regarding the effect of meteorological conditions upon the ionization of the atmosphere see K. FISCHER, *ETZ*, **32**, 339, 1911.
- ²³⁶ *Jahrb.*, **5**, 532, 1911.
- ^{236a} A. BLONDEL⁴¹ was probably the first to indicate that these upper strata might play an important part in determining wave propagation (see, *e.g.*, B. J. ERSKINE-MURRAY¹). This view is based on the assumption of a *very* good conductivity for the upper layers of the atmosphere. There is no justification for supporting this assumption by reference to conditions in the GEISSLER tube or in J. J. THOMSON'S current loop without electrodes, for in both these cases the gas is ionized by a *very strong electric field*, which does not exist in the upper atmospheric strata in wireless telegraphy.
- ²³⁷ J. A. FLEMING, *The Marconigraph*, **2**, 179, 1912. G. W. PIERCE,¹ p. 139 states that A. E. KENNELLY has shown the effect of day and night to be due to a change in the wave front.
- ²³⁸ According to DR. A. MEISSNER, heavy winds of long duration, which tend to eradicate existing heterogeneity in the atmosphere, increase the distance effect. LEE DE FOREST (*Jahrb.*, **6**, 167, 1912) reports a very remarkable observation of *interference* due to heterogeneity.
- ²³⁹ G. MARCONI, *El.*, **49**, 521, 1902; **54**, 824, 1905.
- ²⁴⁰ See *Jahrb.*, **5**, 621, 1912; **6**, 151, 154, 1912. A. TURPAIN, *C. R.*, **154**, 1457, 1912. W. H. ECCLES, *El.*, **69**, 109, 1912. J. A. FLEMING, *El.*, **69**, 190, 1912; *TELEFUNKENZEITUNG*, **1**, 89, 1912. So many observers have failed to find any effect due to solar eclipses and others have found so slight an effect, that it may be concluded that this effect is hardly greater than the extent of the errors involved in these measurements.
- ²⁴¹ G. MARCONI, *El.*, **64**, 379, 1909. H. J. ROUND had already (*El.*, **56**, 714, 1906) stated that the difference between day and night range is much greater with short than with long waves.
- ⁴⁴² Tests made at the Braunschweig physik. Inst., 1907.
- ²⁴³ For tests on damping of antennæ in daylight and at night see note²³⁴; also H. MOSLER, *ETZ*, **30**, 301, 1909 and P. SCHWARZHaupt, *ETZ*, **32**, 1313, 1912.
- ²⁴⁴ L. W. AUSTIN, *Jahrb.*, **5**, 75, 1911; *Bull. Bur. Stands.*, **7**, 315 *et seq.*, 1911.

- ²⁴⁵ L. W. AUSTIN, *Jahrb.*, **5**, 417, 1912.
- ²⁴⁶ K. SOLFF, *ETZ.*, **1906**, 896.
- ²⁴⁷ J. A. FLEMING,¹ J. ERSKINE-MURRAY¹ and G. W. PIERCE¹ give general and in some cases more complete presentations of this subject. Also see S. SACHS, *Jahrb.*, **1**, 130, 279, 434, 584, 1908. E. NESPER, *Jahrb.*, **4**, 312, 423, 534, 1911.
- ²⁴⁸ C. TISSOT, *Electrician*, **56**, 848, 1906; *Industrie électrique*, **14**, 161, 1906; *Journal de Physique*, **6**, 279, 1907.
- ²⁴⁹ G. MARCONI, *Proc. Royal Soc.*, **77**, 413, 1906; *Electrician*, **57**, 100, 1906.
- ²⁵⁰ Regarding thermal detectors: W. H. ECCLES, *El.*, **60**, 587, 1908. C. TISSOT, *Jahrb.*, **2**, 115 *et seq.*, 1908. E. NESPER²⁴⁷, references in *Jahrb.*, **3**, 370, 430 (1910); **4**, 232 *et seq.* (1911). On thermal detectors with a rotating electrode, see *El.*, **62**, 211, 1908 (L. W. AUSTIN); *Jahrb.*, **2**, 144, 1908 (TELEFUNKEN).
- ²⁵¹ Review of various magnetic wave indicators not covered by note²⁴⁷: L. H. WALTER, *Electrician*, **55**, 83, 1905. For explanation of their action see L. H. WALTER and E. MADELUNG, *Ann. Phys.*, **17**, 861, 1905; W. H. ECCLES, *Electrician*, **57**, 742, 1906; J. RUSSEL, *Proc. Royal Soc.*, Edinburgh, Nov. 20, 1905. E. WILSON, *Electrician*, **51**, 330, 1897, was probably the first to describe a magnetic detector.
- ²⁵² As the magnetic detector is most sensitive in a definite portion of the magnetization cycle, the magnetic detector of the so-called BALSILLIE system is comprised of three detectors, of the type shown in Fig. 317, each of which is automatically connected into circuit at the moment when it is in the most sensitive part of the magnetization curve (*Jahrb.*, **4**, 292, 1911; *El.*, **64**, 512 *et seq.*, 1910).
- ²⁵³ G. MARCONI, *Electrician*, **54**, 825, 1905.
- ²⁵⁴ R. ARNÒ, *Electrician*, **55**, 469, 1905; *ETZ*, **1904**, 480. J. A. EWING and L. H. WALTER, *Proc. Roy. Soc.*, **73**, 120, 1904. L. H. WALTER, *Proc. Roy. Soc.*, **77**, 538 *et seq.*, 1906. W. PEUCKERT, *ETZ*, **1904**, 992. A. G. ROSSI, *Phys. Zeitschr.*, **10**, 549, 1909. R. A. FESSENDEN, D.R.P., 227102 (1909).
- ²⁵⁵ Review of a large number of articles dealing with the action of the coherer in note²⁴⁷ and also by P. WEISS, *Journal de Phys.* (4), **5**, 462, 1906. A. BLANC, *Journal de Phys.* (4), **4**, 743, 1905.
- ²⁵⁶ German patent application by A. KOEPEL in 1902. O. LODGE and A. MUIRHEAD, *Electrician*, **50**, 930, 1903.
- ²⁵⁷ L. H. WALTER, *Jahrb.*, **2**, 120, 1908; *Electrician*, **61**, 683, 1908.
- ²⁵⁸ J. E. IVES, *Jahrb.*, **4**, 112, 1910.
- ²⁵⁹ Regarding the liquid barretter see S. M. KINTNER, *Proc. Amer. Inst. El. Engrs.*, **26**, 65 *et seq.*, 1907. J. E. IVES, *Phys. Zeitschr.*, **11**, 1181, 1910.
- ²⁶⁰ *Jahrb.*, **5**, 432, 1912.
- ²⁶¹ Also see C. TISSOT, *Electrician*, **60**, 25, 1907; C. R., **145**, 226, 1907. J. S. SACHS, in *Jahrb.*, **1**, 584 *et seq.*, 1908, quotes additional articles on the action of the electrolytic detector.
- ²⁶² R. FESSENDEN, *ETZ*, **1905**, 950.
- ²⁶³ F. BRAUN, *ETZ*, **1906**, 1199; *Electrician*, **58**, 569, 1907. PSILOMELAN detector, *Jahrb.*, **4**, 432, 1911. DUNWOODY detector, *El. World*, **48**, 370, 1906. G. W. PIERCE detector, *Lum. él.*, **1**, 92, 1908; *Jahrb.*, **3**, 370, 1910. G. J. PICKARD detectors, *Jahrb.*, **3**, 430, 1910; *Lum. él.*, **11**, 172, 1910 (article by P. BRENOT). W. H. ECCLES, *El.*, **60**, 588, 1908.
- ²⁶⁴ Regarding the action of crystal detectors see G. W. PIERCE,¹ H. SUTTON, *El.*, **69**, 66, 1912. C. TISSOT, *l'Electricien*, **39**, 331, 1910. R. H. GODDARD, *Phys. Rev.*, **34**, 423, 1912.
- ²⁶⁵ J. A. FLEMING, *Proc. Roy. Soc.*, **74**, 476, 1905; *El.* **55**, 303, 1905. Data relative to incandescent lamp type of detectors and their connections in *Electrician*, **61**, 804, 843, 1006, 1908; **62**, 211, 1908; **63**, 504, 1909; **64**, 68, 1909. Review of

- various detectors with rarified gases: C. TISSOT, *El.*, **58**, 729, 1907; *ETZ*, **1908**, 172.
- ²⁶⁶ A. WEHNELT, *Ann. Phys.*, **19**, 153, 1906.
- ²⁶⁷ H. BRANDES, *ETZ*, **1906**, p. 1015.
- ²⁶⁸ *Jahrb.*, **3**, 429, 1910 and Q. MAJORANA, *Jahrb.*, **2**, 347 *et seq.*, 1909.
- ²⁶⁹ P. LUDEWIG, *Jahrb.*, **3**, 411, 1911 (electrolytic cell); G. W. PIERCE, *Jahrb.*, **3**, 498, 1910; *El. Review*, **28**, 56 *et seq.*, 1909; *El.*, **64**, 183 *et seq.*, 1909 (electrolytic cell); *El.*, **64**, 425, 1909 (crystal detectors). K. BANGERT, *Phys. Zeitschr.*, **11**, 123 *et seq.*, 1910 (galena detector). L. W. AUSTIN, *Bull. Bur. Stands.*, **5**, No. 1, 1908. W. H. ECCLES, *El.*, **65**, 735, 1910; *El.*, **66**, 166 *et seq.*, 1910.
- ²⁷⁰ Compare C. TISSOT, *Electrician*, **58**, 730, 1907; **60**, 25, 1907. J. A. FLEMING.¹
- ²⁷¹ Apparatus or methods for testing detectors described in the following: J. A. FLEMING and G. B. DYKE, *El.*, **63**, 216, 1909. P. JÈGOU, *ETZ*, 720, 1908. The commercial form of detector testing apparatus of the TELEFUNKEN Co. is described in *Jahrb.*, **6**, 391, 1913.
- ²⁷² *Jahrb.*, **4**, 212 *et seq.*, 1910.
- ²⁷³ COUNT ARCO.¹⁶⁰ G. EICHHORN, *Jahrb.*, **5**, 301 *et seq.*, 1911. For other proposed method for sound intensification, see P. JÈGOU, *l'Electricien*, **37**, 129, 1910. HENRY, *l'Electricien*, **38**, 11, 1910.
- ²⁷⁴ *Phys. Zeitschr.*, **13**, 38, 1912.
- ²⁷⁵ For further details see H. SIMON, *Jahrb.*, **2**, 409 *et seq.*, 1909.
- ²⁷⁶ Bulletin No. 12 of the TELEFUNKEN Co. Capillary relay of ARMSTRONG-ORLING, *ETZ*, **1906**, p. 385. M. CANTOR had already constructed a similar relay as early as 1900.
- ²⁷⁷ COUNT ARCO.¹⁶⁰ G. EICHHORN, *Jahrb.*, **4**, 405 *et seq.*, 1911. Also see *ETZ*, **32**, 776, 1911. Regarding proposal of C. LORENZ to use a selenium cell see *Jahrb.*, **3**, 622, 1910.
- ²⁷⁸ J. TAYLOR, *El.*, **41**, 278 *et seq.*, 1911. GRUNICKE, *ETZ*, **32**, 64, 1911. TH. BAKER, *ETZ*, **32**, 696, 1911 and *El.*, **67**, 363, 1911.
- ²⁷⁹ See *El.*, **54**, 825, 1905; **63**, 908, 1909; *l'Electricien*, **39**, 93, 1910; *Jahrb.*, **4**, 524, 1911. *ETZ*, **32**, 1164, 1911.
- ²⁸⁰ MARCONI, in some of his stations, makes use of the so-called "earth arrester," which consists in the main of two metal plates close together, inserted in the ground connection of the antenna and having the receiving circuit in parallel thereto. When transmitting the spark resulting between these plates short-circuits the receiving circuit. As soon as transmission is over the receiving system is back in circuit. See E. NESPER.¹⁹¹
- ²⁸¹ G. O. SQUIER, *Electrician*, **54**, 836 *et seq.*, 1905; **55**, 453, 1905.
- ²⁸² See R. RÜDENBERG, *Ann. Phys.*, **25**, 446, 1908. Also see H. BARKHAUSEN, *Jahrb.*, **2**, 40, 1908; **5**, 261, 1912.
- ²⁸³ J. ERSKINE-MURRAY.¹ This also shows illustrations of LODGE-MURHEAD apparatus.
- ²⁸⁴ F. BRAUN, D.R.P. 136641 (1901).
- ²⁸⁵ F. KIEBITZ, *ETZ*, **33**, 132, 1912. K. BANGERT, *Phys. Zeitschr.*, **11**, 123 *et seq.*, 1909.
- ^{285a} A great number of methods for making use of the two coupling waves have been proposed. J. A. FLEMING (*El.*, **63**, 333, 1909) *e.g.*, proposes to use an arrangement like Fig. 391; but one portion shall be tuned to one wave, the other portion to the other wave. The currents of the two detectors act upon the same telephone, which has two windings for this purpose. Probably no such arrangement has ever been used in practice.
- ²⁸⁶ H. RIEGGER, *Jahrb.*, **5**, 35, 1911. For the theory of three very loosely coupled circuits see B. MACKÛ, *Jahrb.*, **4**, 188, 1911. P. O. PEDERSEN, *Jahrb.*, **3**, 283, 1910; **4**, 449, 1911. F. MÜLLER, *Jahrb.*, **6**, 13, 1912.

- ²⁸⁷ *ETZ*, **33**, 376, 1912.
- ²⁸⁸ L. W. AUSTIN, *Bull. Bur. Stands.*, **7**, 301, 1911.
- ²⁸⁹ M. WIEN, *Ann. Phys.*, **8**, 696, 1902. Experiments of L. MANDELSTAM and H. BRANDES at the Strassburg Forts in the summer of 1902.
- ²⁹⁰ R. FESSENDEN, *El. Rev.*, **59**, 77 *et seq.*, 1906; *Electrician*, **62**, 172, 1908; **65**, 314 *et seq.*, 1910. The use of a number of condenser circuits in the receiver for the purpose of increasing the sharpness of resonance has been proposed by both J. S. STONE and the MARCONI Co. (*Electrician*, **62**, 171, 1908).
- ²⁹¹ F. BRAUN, address at Strassburg, 1905.
- ²⁹² COUNT VON ARCO, *ETZ*, **31**, 506 *et seq.*, 1910; *Jahrb.*, **4**, 79 *et seq.*, 1910.
- ²⁹³ Regarding atmospheric disturbances see J. ERSKINE-MURRAY, *Jahrb.*, **5**, 108, 1911. P. SCHWARZHaupt, *El.*, **65**, 820, 1910. J. E. TAYLOR, *El.*, **66**, 1022, 1911. W. H. ECCLES and H. M. AUREY, *Proc. Roy. Soc.*, **85**, 145, 1911. A. ESAU, *Phys. Zeitschr.*, **12**, 798, 1912. F. G. LORING, *El.*, **67**, 27, 1911. M. DIECKMANN.¹⁵¹
- ²⁹⁴ See J. ERSKINE-MURRAY,¹ *El.*, **68**, 465, 1911.
- ²⁹⁵ See *Jahrb.*, **4**, 404, 1911.
- ^{295a} In the "reducteur d'interférence" of the BALSILLIE System (*Lum. él.*, **9**, 404, 1910) a highly damped condenser circuit is coupled with the antenna. It is tuned to the frequency of the interfering station and is intended to absorb the oscillations caused by it in the receiver.
- ²⁹⁶ *L'Electricien*, **41**, 278, 1911.
- ^{296a} R. FESSENDEN, *El. Rev.*, **59**, 38, 1906.
- ²⁹⁷ A. BLONDEL, *Compt. rend.*, **130**, 1383, 1900.
- ^{297a} M. WIEN, *Phys. Zeitschr.*, **13**, 1034, 1912.
- ²⁹⁸ ANDERS BULL, *Electrician*, **54**, 142, 1904. Regarding the HOVLAND apparatus see *Jahrb.*, **5**, 394, 1912.
- ²⁹⁹ E. NESPER, *Jahrb.*, **4**, 534 *et seq.*, 1911.
- ³⁰⁰ *Jahrb.*, **1**, 430, 1908; **2**, 419, 1909.
- ³⁰¹ Regarding "ticker" and ticker connections see *Jahrb.*, **1**, 144, 1907. E. NESPER, *Jahrb.*, **4**, 317, 547, 1911. H. MOSLER, *ETZ*, **32**, 1027, 1911. F. KIEBITZ, *ETZ*, **33**, 132, 1912.
- ³⁰² *Jahrb.*, **5**, 113, 1911.
- ³⁰³ L. W. AUSTIN, *Phys. Zeitschr.*, **12**, 867, 1912.
- ³⁰⁴ *Electrician*, **59**, 985, 1907; *El. Rev.*, **60**, 251 *et seq.*, 329, 368 *et seq.*, 1907. Report of DE FOREST on tests with this detector in *Electrician*, **60**, 135, 1907.
- ³⁰⁵ R. GOLDSCHMIDT, *El.*, **68**, 464, 1911; *Jahrb.*, **5**, 341, 1911.
- ³⁰⁶ See E. BELLINI, *Jahrb.*, **2**, 381 *et seq.*, 1909 and L. H. WALTER, *El.*, **64**, 790 *et seq.*, 1910. In these articles a large number of distance effect characteristics are calculated and plotted.
- ³⁰⁷ If r represents the distance between the points P and O (Fig. 405), then, under the assumptions of Fig. 406, the field of antenna B at the point P is of the form

$$E_0 \sin \left(\omega t - \frac{2\pi r}{\lambda} + \frac{\varphi}{2} \right)$$

that of antenna A is of the form

$$E_0 \sin \left(\omega t - \frac{2\pi r}{\lambda} - \frac{\varphi}{2} - \psi \right)$$

whence the resultant field is of the form

$$\begin{aligned} E_r &= E_0 \left\{ \sin \left(\omega t - \frac{2\pi r}{\lambda} + \frac{\varphi}{2} \right) + \sin \left(\omega t - \frac{2\pi r}{\lambda} - \frac{\varphi}{2} - \psi \right) \right\} \\ &= 2E_0 \cos \frac{\varphi + \psi}{2} \sin \left(\omega t - \frac{2\pi r}{\lambda} - \frac{\psi}{2} \right) \end{aligned}$$

It follows from this that the amplitude of the resultant field is

$$Er_0 = 2E_0 \cos \frac{\varphi + \psi}{2} = 2E_0 \cos \left[\frac{\pi d}{\lambda} \cos \vartheta + \frac{\psi}{2} \right]$$

This expression determines the distance effect characteristic.

- ³⁰⁸ See J. A. FLEMING,¹ S. G. BROWN, English patent 14449 (1899). A. BLONDEL² and Lum. él., **16**, 7, 131, 1911.
- ³⁰⁹ Regarding the BELLINI and TOSI methods see Jahrb., **2**, 239 *et seq.*, 381 *et seq.*, 511 *et seq.*, 609 *et seq.*, 1909; **3**, 571 *et seq.*, 595 *et seq.*, 1910. Société internationale des électriciens. Extrait du Bulletin (2) **8**, No. 80, El. **65**, 861, 1910; **67**, 66, 1911.
- ³¹⁰ Jahrb., **2**, 190 *et seq.*, 1909.
- ³¹¹ F. BRAUN, Jahrb., **1**, 1, 1907; Electrician, **57**, 222 *et seq.*, 244 *et seq.*, 1906.
- ³¹² Lum. él. (2), **13**, 227 *et seq.*, 1911.
- ³¹³ L. MANDELSTAM and N. PAPALEXI, Phys. Zeitschr., **7**, 303, 1906. Also see A. JOLLOS, Diss. Strassburg, 1907 and M. DIECKMANN, Diss. Strassburg, 1907.
- ³¹⁴ Proc. Roy. Soc., **77**, 413, 1906; Electrician, **57**, 100, 1906. Data on transatlantic stations at CLIFDEN and GLACE BAY in: Electrician, **60**, 883, 1908. According to F. GALLIOT (Electrician, **57**, 183, 1906) similar experiments were made by GARCIA as early as 1900. K. E. F. SCHMIDT in Phys. Zeitschr., **8**, 5, 1908 proposed the use of a directive transmitter having a vertical portion and a ground network extending only in one direction. Experiments with various antennæ with horizontal parts described by F. KIEBITZ, Ann. Phys., **32**, 941, 1910.
- ³¹⁵ MONCKTON, Radiotelegraphy, p. 144.
- ³¹⁶ Diss. München, 1911; Jahrb., **5**, 14 *et seq.*, 188 *et seq.*, 1911.
- ³¹⁷ As early as 1901 DE FOREST had already called attention to the fact that horizontal antennæ can be used with directive receivers. See J. A. FLEMING,¹ G. W. PICKARD, Electrician, **59**, 564, 1907. Regarding the action of the bent MARCONI antenna as a receiver, see J. ZENNECK, Phys. Zeitschr., **9**, 50 *et seq.*, 1908.
- ³¹⁸ Regarding earth antennæ and their history, see L. ZEHNDER, Jahrb., **5**, 594, 1912. F. KIEBITZ, Verhandl., Jahrb., **5**, 360, 1912; **6**, 1, 1912. Also see ETZ, **33**, 139, 1912; El., **68**, 936, 978, 1020, 1912. F. BRAUN, Jahrb., **5**, 586, 1912.
- ³¹⁹ L. W. AUSTIN, Jahrb., **5**, 419, 1912. Austin states that the energy of waves from CLIFDEN measured at Brant Rock is greater than would correspond to the height of the Clifden antenna and the energy used at Clifden. However, the assumptions on which his calculations are based are rather doubtful.
- ³²⁰ J. E. TAYLOR²⁹³ points out the particular freedom from interference of certain arrangements similar to those of BELLINI and TOSI.
- ³²¹ Instead of adjusting the receiver for minimum or maximum sound intensity, the direction of the transmitter can be determined by measuring the current effects produced in the detector circuits of two receivers and finding their ratio. See El., **65**, 898, 1910 and A. BLONDEL³⁰⁸ and Jahrb., **2**, 190 *et seq.*, 1909.
- ³²² l'Electricien, **39**, 177, 1910. P. BRENOT, Lum. él. (2), **11**, 174, 1910.
- ³²³ El., **64**, 833, 1910.
- ³²⁴ See TELEFUNKEN pamphlet entitled "TELEFUNKEN Kompass."
- ^{324a} A. ARTOM, El., **69**, 370, 1912.
- ³²⁵ General treatment: E. RUHMER, "Drahtl. Tel." (Berlin, 1907). W. H. ECCLES, El., **62**, 212 *et seq.*, 1908. G. EICHORN, "Technische Mitteilungen," Vol. XXV Zürich, 1908. R. A. FESSENDEN, El., **59**, 985 *et seq.*, 1907; El. Rev., **60**, 251 *et seq.*, 329 *et seq.*, 368 *et seq.*, 1907; El., **61**, 441, 787, 828, 867, 1908. E. NESPER, Jahrb., **3**, 83 *et seq.*, 1909. Demonstration apparatus of E. HUTH, Jahrb., **3**, 511, 1910. On the theory of radio-telephony see P. O. PEDERSEN, Jahrb., **5**, 449, 1912.

³²⁶ A. F. COLLINS, *Jahrb.*, **4**, 211, 1911; *El.*, **64**, 850, 1910; *ETZ*, **32**, 835, 1911. M. COLIN and R. JEANCE, *El.*, **63**, 511, 1909. W. DUBILIER, *El.*, **67**, 739, 931, 1911, *l'Electricien*, **41**, 231, 1911.

³²⁷ *Jahrb.*, **5**, 237, 1912. Also see DE FOREST, *Jahrb.*, **3**, 404, 1910.

³²⁸ E. NESPER.³²⁵

³²⁹ See G. SEIBT, *Jahrb.*, **3**, 202, 1909. C. TISSOT, *C. R.*, **149**, 281, 1909; *Jahrb.*, **3**, 189, 1909.

If I is the antenna current, \mathcal{E} , the e.m.f. acting upon it, R the resistance of the microphone or the equivalent resistance of the microphone circuit and R_a the effective resistance of the antenna, then (assuming extremely loose coupling and primary circuit in tune with the antenna) we have

$$I_0 = \frac{\mathcal{E}_0}{R + R_a}$$

$$dI_0 = - \frac{\mathcal{E}_0}{(R + R_a)^2} dR = - \frac{\mathcal{E}_0}{R_a} \left(\frac{R/R_a}{1 + R/R_a} \right)^2 \cdot \frac{dR}{R}$$

For a certain value of $\frac{dR}{R}$, i.e., for a certain relative change in the microphone resistance this becomes a maximum for $R = R_a$.

³³⁰ *ETZ*, **33**, 205, 242, 1912.

³³¹ J. MAJORANA, *l'Electricien*, **37**, 257, 1909; *Lum. él.* (2), **11**, 246 *et seq.*, 275 *et seq.*, 1910.

³³² *El.*, **65**, 560 *et seq.*, 1910.

³³³ *Jahrb.*, **1**, 420 *et seq.*, 1908.

³³⁴ *Jahrb.*, **2**, 243, 1909 (Amalgamated Radiotel. Co.).

³³⁵ O. SCHELLER, *Jahrb.*, **3**, 533, 1910.

³³⁶ COUNT ARCO, *Jahrb.*, **4**, 79 *et seq.*, 1910.

³³⁷ A. MEISSNER'S method consists in the main of the following: A number of spark gaps in series, whose number and gap length are so chosen that the voltage of the generator or transformer is not able to jump across them is employed. If, however, one or more of these gaps is bridged by means of an auxiliary excitation, a discharge takes place across the entire series.

With direct-current operation, this method makes it possible to obtain an absolutely regular discharge rate. For this purpose it offers a more simple means than a rotating gap and moreover is adaptable to very low voltages. See.³⁴⁴

³³⁸ V. POULSEN, *Jahrb.*, **2**, 419, 1909.

³³⁹ S. EISENSTEIN, *Jahrb.*, **2**, 417, 1909. H. REIN, *Jahrb.*, **4**, 196, 1911.

³⁴⁰ *Jahrb.*, **5**, 118, 1911; D.R.P., 227989 (1910).

³⁴¹ D.R.P., 245445 (1912).

³⁴² J. ZENNECK, *Wied. Ann.*, **69**, 858, 1899. This same method later became the basis of U. S. Patent of H. SHOEMAKER and H. CLYDE SNOOK (No. 736884, 1903).

³⁴³ D.R.P., 149761 (1902).

³⁴⁴ COUNT ARCO, Address before convention of "Naturforscher," Münster, 1912.

³⁴⁵ J. ZENNECK, *Phys. Zeitschr.*, **13**, 953, 1912.

³⁴⁶ Regarding the efficiency of radio-telegraph stations from various scientific and commercial points of view, see: J. ERSKINE-MURRAY, *Lum. él.*, **16**, 331, 1911.

³⁴⁷ C. TISSOT and F. PELLIN, *Jahrb.*, **2**, 525, 1909. C. TISSOT, *El.*, **67**, 333, 1911. P. BRENOT, *Lum. él.* (2), **12**, 368, 1910. G. EICHHORN, *Jahrb.*, **4**, 642 *et seq.*, 1911.

³⁴⁸ *Jahrb.*, **4**, 216, 417, 1911.

³⁴⁹ P. BRENOT, *Lum. él.* (2), **12**, 387 *et seq.*, 1910. C. TISSOT, *Jahrb.*, **4**, 618 *et seq.*, 1911.

³⁵⁰ G. REMPP, Experiments in Strassburg, Elsass. Also see *El.*, **65**, 131, 1910. Re-

garding other applications in meteorology also see Jahrb., **2**, 529, 1909; **3**, 581, 1910.

³⁵¹ Curves for determination of wave-length from capacity and self-induction by W. W. MASSIE, *El.*, **57**, 826, 1906.

³⁵² Recent articles on the static characteristic of arcs with different electrodes and gases: W. L. UPSON, *El.*, **59**, 60 *et seq.*, 90 *et seq.*, 1907. H. TH. SIMON, *Phys. Zeitschr.*, **8**, 471 *et seq.*, 1907. C. E. GUYE and L. ZÉBRKOFF, *Phys. Zeitschr.*, **8**, 703, 1907. HEUBACH, *ETZ*, **13**, 460, 1892. General: "Das elektrische Bogenlicht" by E. RASCH (in "Die Elektrotechnik in Einzeldarstellungen"). Braunschweig, 1910.

³⁵³ See Notes ⁴⁴ and ⁴⁵. A. ESAU, *Jahrb.*, **5**, 212, 378, 1912. Esau simplifies STRASSER'S equation to the form:

$$L = 4\pi rn \left\{ \log_e \frac{r}{\rho} + 0.333 + S \right\}$$

and gives tables for the values of S , which depends only on $\frac{l}{2r}$ and n .

³⁵⁴ *EMS*, 409 *et seq.*

³⁵⁵ Also see L. W. AUSTIN in *Jahrb.*, **6**, 588, 1913, which also gives the maximum loads for constantan, manganin, platinum and copper wires.

INDEX

A

- ABRAHAM, M., Field of the lineal oscillator, 27, 31, 409
 On the general theory of electricity, 410
- Absorption of ions, 97
 of waves by the earth's surface, 249
et seq.
- Acoustic resonance, 291 *et seq.*, 297, 330
- ADELMANN, L., and W. HAHNEMANN, 409
- Advancing waves, 26, 29
- Aerials, various forms of, 150
- Air blowers—blasts, 187, 240
- AIREY, H. M., and W. H. ECCLES, 425
- Airship antennæ, 163, 169
- Airships, reception of messages in, 302
- ALEXANDERSON, E. F. W., 213
- ALGERMISSEN, J., 412
- Alternating current operation, 195
 resistance, 48
 magnetic field, 2
- Alternators, High frequency, 213 *et seq.*, 371
- Amplitude, 11, 12
 curve, 12
 of condenser circuits with spark gap, 13
 without spark gap, 11
- ANDERLE, A, 408
- ANDERSON, H., 408
- Antennæ, 150 *et seq.*, 382
 artificial, 169
 bent Marconi, 356 *et seq.*
 damping of, 167
 directive, 341 *et seq.*, 356 *et seq.*
 effective capacity of, 165
 self-induction of, 164
 horizontal, 364
 with increased end capacity, 152
 with reduced radiation damping, 166
- Anti-coherers, 279
- Anti-node of current, 25
 of potential, 25
- Arc, constants of the, 392
- Arc, generation of undamped oscillations by the Poulsen, 220 *et seq.*
 hysteresis, 232
 oscillations, use of, for measuring purposes, 116, 119, 121, 225
 the term, defined, 245
- ARCO, COUNT G. VON, Call signal, Sound intensifier, 424
 Connections for receiving, 313
 Data regarding Telefunken stations, 167, 417
 Duplex reception with one wave length, 425
 Frequency transformation, 380 *et seq.*
 High frequency alternator, 219, 380, 419
 Sensitiveness of detectors, 289
- ARMSTRONG-ORLING, 424
- ARNÒ, R., 275, 413
- ARTOM, A., Determination of location by radio-telegraphy, 368, 426
- Atmosphere, effect of, upon wave propagation, 263
- Atmospheric disturbances and methods for counteracting, 324, 326, 332
- Audion, 285, 377
- AUSTIN, L. W., Antennæ measurements, 418
 Brant Rock station, 417
 Brush discharge in condensers, 141
 Condensers in high frequency circuits, 409
 Coupled receivers, 425
 Detectors and measurements there-with, 273 *et seq.*, 413, 423
 Resistance wires, 428
 Rotating ticker, 335
 Thermocouple, 75
 Wave propagation measurements, 258, 265, 269, 421, 426
 Wireless telephony, 371
- Automatic key, 203
- Auxiliary cell or element, 284, 290
 excitation for quenched gap transmitter, 378
- AYRTON, H., 392

B

- BADISCHE ANILIN- UND SODAFABRIK,
Quenched spark gap, 187
- BAKER, TH., 424
- BALSILLIE system, 207, 425
- BANGERT, K., Detectors, 424
Receiver connections, 424
- BARKHAUSEN, H., Action of receivers, 424
Arc method for generating un-
damped oscillations, 231, 234,
420, 421
Radiation resistance of antennæ, 410
Spark gap resistance, 15
- BARRECA, P., Ground resistance, 417
Radiation of open oscillators and
antennæ, 410
- Barretter, 72, 77, 272
- BEGGEROW, H., Airship antenna, 163
- BELLINI, E., Distance effect character-
istics, 425
and A. TOSI, Arrangements for
directive telegraphy, 347 *et seq.*,
367 *et seq.*
- BENISCHKE, G., 415
- Bent Marconi antenna, 356 *et seq.*
- BETHENOD, J., Effective resistance of
rectangular wires and strips, 412
Resonance inductor, 415
- BIERLEIN, W., 415
- Bilateral transmitter for directive tele-
graphy, 345
- BIRKELAND, K., 421
- BJERKNES, V., Loose coupling of oscil-
lators, 85
Resonance method, 113, 114, 118
- BLACK, TH. P., 411
- BLANC, A., 423
- Block condenser, 64, 290
- BLONDEL, A., Antenna with increased
end capacity, 411
Arc generator, 420
Directive transmitter, 345 *et seq.*, 426
Mechanical tuning, 331
Part played by upper layers of the
atmosphere, 422
Studies of the arc method, 231, 236
Tone transmitter, 377
Waves produced by grounded an-
tenna, 421
- Blowers, air, 187, 240
- Blow-out, magnetic, 187, 240, 242 *et seq.*
- BOAS, H., Coherer, 278
Condensers, 60, 140
Incandescent lamp oscillograph, 4
Quenched spark gap, 95
Resonance inductor, 198, 415
Rotating mirror for high speeds, 4
- Bolometer, 72, 77, 272
- Boulogne, station for directive tele-
graphy, 351
- Braided wire, 48, 49
- Braids of individually insulated wires, 48,
49
- BRANDES, H., Action of detectors, 284
Determination of the decrement, 116
Thermocouple, 75, 77, 413
and L. MANDELSTAM, Coupling for
tuned telegraphy, 322
- BRANLY, 277
- Brant Rock station, 152, 165
- BRAUN, F., Braun transmitter, 175, 184,
209
tube, 2, 231
Directive telegraphy employing sev-
eral antennæ, 352
inclined antennæ, 363
Energy connections, so-called, 178
Ground antennæ, 426
Hot-wire-air thermometer, 71
Psilomelan detector, 282
Receiver connections, 311
Sparkless key, 203
Triple reception using one antenna,
425
- Breakdown voltage, 64, 232, 399
- BREDOW, H., 417
- BRENOT, P., Arc generator of Blondel,
420
Eiffel Tower station, 412
Experiments with Bellini and Tosi
arrangements, 367
Frequency meter of Ferrié, 412
Longitude determination by radio
telegraphy, 427
Radio time signals, 427
Resonance inductor, History of the,
415
- BRION, B. G., 419
- BROWN, S. G., Detector, 282
Directive transmitter, 345
Telephone relay, 291
- Brush discharge of antennæ, 167, 168
of coils, 34
of condensers, 21, 86
insulation against, 168

- BRYLINSKY, Resistance with oscillating currents, 412
- BULL, A., 332
- BURSTYN, W., Ground currents, ground resistance, 417
Key arrangement, 419
Multitone transmitter, 229
Rotating spark gap, 419
- C
- Call signal, apparatus for calling, 299, 300
- CAMPBELL, A., 416
- CANTOR, M., 424
- Capacity, determination of, 112
Effective, of open oscillators or antennæ, 40, 164, 165
End, of open oscillators or antennæ, 41, 42
in the arc transmitter, 227, 241
of coils, 113
of condensers in oscillation, 8
resultant, 6
unit of, 6
- Carbon coherer, 279
- Carborundum detector, 282, 286 *et seq.*
- CASTELLI, Mercury coherer, 278
- Cathode ray tube, 2
- CHAFFEE, E. L., 184, 408
- CHAMBERS, F. J., 374
- Characteristic of the arc, 231 *et seq.*
of detectors, 285 *et seq.*
of the distance effect, 338, 342 *et seq.*
- Charging stage in the arc method, 235
- Choke coils, 64, 199, 291, 323
- Circuit losses, 138
- Clifden, station at, 266 *et seq.*
- Close coupling, 81, 87 *et seq.*
- Closed oscillator, oscillating circuit, 24
- CLYDE, H., 427
- Coastal contour, effect of, on wave propagation, 263
- COFFIN, 393
- COHEN, B. S., 73, 413
- COHEN, L., Effective resistance of coils, 412
Theory of coupled circuits, 415
- Coherers, 276 *et seq.*
- COHN, E., 408
- Coils, effective resistance and self-induction of, 47 *et seq.*
having adjustable self-induction, 51
- Coils in open oscillators and antennæ, 44 *et seq.*, 165
natural oscillations of, 33
various forms of, 50 *et seq.*
- COLIN, M., and R. JEANCE, 371
- COLLINS, A. F., 371
- Compass, radio, 368 *et seq.*
- Compressed air or gas condensers, 55, 57, 179
spark gaps, 418
- Condenser circuits, natural frequency of, 5, 384
oscillations of, 1 *et seq.*
wave length of, 5, 386
- Condensers, adjustable, 59 *et seq.*
brush discharge in, 21, 138 *et seq.*
in open oscillators, or antennæ, 41, 165
losses in, 20, 138
various forms of, 54 *et seq.*, 179
- Conductivity of earth and water, 248
- Conical antenna, 151, 169
- Continuous oscillations. See *Undamped oscillations.*
- CORBINO, O. M., Arc method, 420
High frequency generator, 420
- Counterposie, 157
- Coupled circuits, 79 *et seq.*, 142 *et seq.*
transmitters, 175 *et seq.*, 208
- Coupling, capacity or electric, 81
close, 81
coefficient of, 82
conductive, direct galvanic, 79, 80
critical degree of, 96, 149
degree or percentage of, 89, 401, 402
in Braun transmitter, 176 *et seq.*
in Wien transmitter, 184, 185
devices and arrangements for, 82 *et seq.*
inductive or magnetic, 79
loose, 81
of damped oscillating circuits, 84 *et seq.*
of undamped oscillating circuits, 99 *et seq.*
oscillations—waves, 88
- Crystal detectors, 282 *et seq.*
- Cullercoats, station at, 225, 302
- Current, anti-node of, 25
curve, 2
distribution, curve of, 24, 25, 155
effect, 67

- Current, measurement of, 67 *et seq.*
 node of, 25
 path, 1, 179
- Curvature of earths surface, effect of,
 on wave propagation, 255
- Cylindrical coils, 52, 393
- D
- Damped oscillations, 2
- Damping, 2, 5, 9 *et seq.*
 causes of, 11, 40, 41, 167 *et seq.*
 of antennæ, 167 *et seq.*
 of condenser circuits, 9 *et seq.*
- Daylight, effect of, on wave propagation,
 265 *et seq.*
- Decrement, joulean, 12, 167
 lineal, 14
 logarithmic, 12
 measurement of the, 113 *et seq.*, 118
et seq., 125 *et seq.*, 135
 total, 15
- Decrements, oscillation curves for va-
 rious, 389 *et seq.*
- Decremeter, 126
- Deionization of a spark gap, 97, 98
- Detector circuit in the receiver, 310, 313,
 375
- Detectors, 272 *et seq.*
 action of, 282, 283, 287 *et seq.*
 crystal, 282
 efficiency of, 287
 electrolytic, 280
 magnetic, 274
 overloading, 301
 sensitiveness of, 289
 thermal, 272
 used for measuring current, 76, 78
- DIECKMANN, M., Measurements with the
 Mandelstam and Papalexi
 method, 426
 Wireless telegraphy in connection
 with airships, 418
- Dielectric constant, determination of, 112
 of soils, etc., 248
 hysteresis, losses due to, 20, 138
- DIESSELHORST, H., Frequency of con-
 denser circuits, 408, 416
 Oscillograph records, 4, 89, 415
- Diffusion of ions, 97
- Direct coupling, 80, 175 *et seq.*, 311
 current operation of radio apparatus,
 194, 198, 199
- Directive power of a transmitter, 338
 telegraphy, 338 *et seq.*, 365 *et seq.*, 381
- Discharge analyzer, 69
 frequency, 68, 69, 211, 378
 potential, 64, 232, 399, 400
 retardation of the, 65, 208
- Discharging stage in the arc method, 235
- Dissonance, necessary, 316, 318
- Distance effect of open oscillators and
 antennæ, 35 *et seq.*, 156
 characteristic, 338
 of bent Marconi antenna, 356
et seq.
 of several antennæ, 342 *et seq.*
 measurement of wave length at a,
 329
- DOENITZ, 129
- DOLEZALEK, F., 49
- DORN, E., 108
- Double antennæ, 341 *et seq.*
 cone antenna, 151, 169
- DOWSE, C. M., 413
- DRUDE, P., Coupled circuits, 90 *et seq.*
 Oscillations of coils, 409
- DUBILIER, W., 371
- DUCRETET, F., and E. ROGER, Conden-
 sers, 179
 Experiments with coupled trans-
 mitters, 175
 Rotating spark gap, 204 *et seq.*
- DUDELL, W., Arc method, 221, 231, 420
 Thermal galvanometer, 75, 272
 Undamped oscillations, 419
 and J. E. TAYLOR, Experiments on
 wave propagation, 260, 269, 272
- DUNWOODY, 282
- Duplex reception, 323 *et seq.*
 transmission, 325
- DYKE, G. B., and J. A. FLEMING, 409, 424
- Dynamic characteristic of the arc, 231
- Dynamometer, 135 *et seq.*
 effect, 132 *et seq.*
- E
- Earth. See *Ground, ground currents,*
ground resistance, etc.
 arrester, 424
- Earth's surface, effect of, on wave propa-
 gation, 246 *et seq.*
- EBERT, H., 422
- ECCLES, W. H., Detectors, 279, 287, 423
 Effect of solar eclipse, 422

- ECCLES, W. H., Wireless telephony, 426
and H. M. AIREY, Atmospheric disturbances, 425
and A. J. MACKOWER, Quenched gap transmitter, 419
- Eclipse of the sun, effect of, on the range of operation, 266
- Eddy currents, 22, 120
- EDELMANN, DR., & SON, 295
- EDWARDS, W., 412
- Effective resistance, 48
- Efficiency of antennæ, 167
of detectors, 287
of various transmitters, 174, 211
- EGER, F., 416
- EGNER, C., and J. G. HOLMSTROEM, 373
- EICHORN, G., Impulse excitation, 182
Practical notes, 424
Wireless telephony, 426
- EICKHOFF, W., Brush discharge in condensers, 138, 139
Points on electrodes, use of, 123
Spark gap damping, 409
- Eiffel Tower station, 49, 165
- EINTHOVEN string galvanometer, 296
- EISENSTEIN, S., Rotating spark gap, 418
Spark gap for impulse excitation, 183
Tone transmitter with undamped oscillations, 427
- Electric or capacity coupling, 81
- Emergency or auxiliary transmitter, 209
- Energy, measurement of, 200 *et seq.*
transfer of, between coupled oscillating circuits, 9, 39
used in radio-telegraphy, quantities of, 381
- EPSTEIN, J., Frequency transformation, 379
- EPSTEIN, P., Waves along the earth's surface, 250
- Equivalent resistance of a closed circuit, 85, 120
- ERB, F., 422
- ERSKINE-MURRAY, J., Cause of atmospheric disturbances, 425
Efficiency of a radio station, 427
"Handbook of Wireless Telegraphy," 408
Radiation resistance, 169
- ESAU, A., Effective capacity, etc., of antennæ, 418
resistance, etc., of coils, 411
- ESAU, A., Node of potential in open oscillators (antennæ), 410
Self-induction of coils, 393, 428
- ESPINOZA DE LOS MONTERAS, A., Instruments for measuring high frequency currents, 413
Quenched spark gaps, 95, 98, 415
- Excitation circuit of Braun transmitter, 175
- Exponential curve, 12
- Extremely loose coupling, 81
- F
- FEDDERSEN, W., 3, 4
- FERRIÉ, Electrolytic detector, 280, 286
Frequency meter, 63
Rotating spark gap, 419
- FESSENDEN, R. A., Barretter, 72, 272
Compressed air condenser, 55, 179, 412
Electrolytic detector, 280 *et seq.*
Heterodyne receiver, 335
High frequency generator, 213
Magnetic detector, 275
Method for securing secrecy of messages, 323
Rotating spark gap, 204
Telephone relay, 374
Water stream used as antenna, 150
Wireless telephony, 371
- Field of an open oscillator, 27, 35
- FISCHER, C., Determination of effective capacity, etc., of antennæ, 165
Experiments with coupled circuits, 91 *et seq.*, 142 *et seq.*, 415
Measurements with undamped oscillations, 416
- FISCHER, K., 422
- FITZGERALD, F., 420
- Flat coils, 50, 393
top antennæ, 152
- FLEMING, J. A., Air blowers for spark gaps, 416
Condensers in oscillating circuits, 408
Degree of coupling in coupled transmitters, 177
Discharge analyzer, 69
Effect of ionization of the atmosphere, 265
of solar eclipse, 422
Gas detector, 283 *et seq.*

- FLEMING, J. A., Incandescent filament detector, 283 *et seq.*
 Oil condenser, 55
 Oscillations of inductive coils, 409
 Receiver connections, 424
 "The Principles of Electric Wave Telegraphy," 408
 Wave meter, 125
 and G. B. DYKE, Investigation of insulators for oscillating potentials, 409
 Testing detectors, 424
- Flint glass, jars and condensers of, 20
- Fluctuation of frequency due to brush discharge from condensers, 138 *et seq.*
 with the arc method, 241
- Fly-wheel connection, the so-called, 166, 228
- FOREST, DE, Detectors, 280, (audion), 285
 Interference of waves, 422
 Wavemeter, 125
- Form factor of an open oscillator or antenna, 37
- FRANKE, Wavemeter, 129
- Frequency, determination of the, 3 *et seq.*, 63, 106 *et seq.*, 123 *et seq.*, 134
 factor, 8, 137
 of arc oscillations, 238 *et seq.*
 of coils, natural, 33
 of condenser circuits, natural, 5 *et seq.*, 384
 of open oscillators or antennæ, natural, 26, 155, 164
 transformation, 379
- Fundamental oscillation of open oscillators, 24, 25
- G
- GALLETTI, R. C., 184
- GALLIOT, F., 426
- Galvanic coupling, 79 *et seq.*
- Gap. See *Spark gap*.
 length, maximum, 64 *et seq.*, 399, 400
- GARCIA, 426
- GÁTI, BÉLA, Barretter, 73, 77, 272
- GEISSLER tube as indicator of electric oscillations, 69
- GEHRKE incandescent lamp oscillograph, 4, 408
- GEITLER, J. VON, 414
- Generators, high frequency, 213 *et seq.*, 371
- GERLACH, W., 76
- Gesellschaft für drahtlose Telegraphie, arc generator, 222
 call signal device, 299 *et seq.*
 commercial radio station apparatus, 167, 192 *et seq.*
 compass, Telefunken, 368 *et seq.*
 condensers, 56 *et seq.*, 60
 detectors, 273, 277, 280, 281, 282
 apparatus for testing, 424
 duplex reception, 324 *et seq.*
 interrupter, 183
 multiplex radio-telegraphy, 324 *et seq.*
- Nauen, station at, 64, 152, 165, 168, 179, 193, 198
 quenched gap transmitter, 192
 spark-gap, 122, 189
 receiver connections, 311 *et seq.*
 for undamped oscillations, 334
 recording reception, 297, 298
 relay, 297
 resonance inductor, 196
 sound intensifier, 291 *et seq.*
 spark-gap construction, 180, 182
 umbrella antenna, 152
 variometer, 54
 wavemeter, 125, 129, 183
- GIEBE standard condenser, 55
- Glace Bay, station at. See *Clifden*.
- GLAGE, G., Coupling of undamped oscillations, resonance inductor, 103
 Equations for coefficient of self-induction 411
- GLATZEL, B., Air blowers for quenched spark gaps, 187
 Hydrogen spark gap, 183
 Mercury arc lamp as quenched spark gap, 415
- GOLDSCHMIDT, R., High frequency generator, 216 *et seq.*, 379
 Receiver for undamped oscillations, 336
 Tone transmitter for undamped oscillations, 378
- GODDARD, R. H., 423
- Goniometer, radio, 350, 367 *et seq.*
- GRANQUIST, G., 420
- Graphite coherer, 279
- GRAY, A., Non-sparking key, 203
- GROBER, M. K., 416

- Ground antennæ, 364
 currents, 158 *et seq.*, 168
 resistance of the, 158 *et seq.*, 172
 water, 160, 260
 wire network, 158
- Grounding of open oscillators, antennæ,
 46, 157, 270, 271
- GROVER, F. W., and E. B. ROSA, 411
- GRUNICKE, 424
- GÜLDENPFENNIG, O., 422
- GUYAU, A., 411
- GUYE, C. E., and L. ZÉBRIKOFF, Arc
 constants, 392
- H
- HACK, F., Field of lineal oscillator, 27
 Propagation of waves along earth's
 surface, 260
- HAHNEMANN, W., Fly-wheel connection,
 420
 Rheostat for high frequencies, 412
 Spark-gap damping, 409
 and L. ADELMAUN, Investigation of
 condensers, 409
- HARMS, F., 409
- Harp-shaped aerial, 151
- HARTMANN and BRAUN hot-wire instru-
 ments, 71
- HENRY, Sound intensifier, 424
- HERMANN, K., 412
- HERTZ, H., Field of open oscillator, 409
 Frequency, determination of, 106
 Hertz oscillator, 41
 Radio reflector experiments, 340
- Heterodyne receiver, 335
- HEUBACH, Arc constants, 392
- HEYDWEILLER, A., Dissipation of energy
 in the spark, 14
 Gap length and breakdown poten-
 tial, 399, 400, 412
- High frequency generators, 213 *et seq.*
 speed telegraph apparatus, 203, 229,
 302
- Hills, effect of, on wave propagation, 258
et seq.
- HILLS, S. H., 413
- HIRSCH, R., 130
- HOLMSTRÖM, J. G., 373
- HÖRSCHELMANN, H. VON, 358 *et seq.*
- Hot-wire air thermometer, 71, 77
 instruments, 71, 77
- HOVLAND, 332
- HUTH, E., Condensers, 55
 Direct reading wavemeter, 130
 String galvanometer, 295
 Wireless telephony, 426
- Hydraulic microphone, 373, 374
- Hydrogen as used in the arc transmitter,
 225 *et seq.*, 240 *et seq.*
 gap, 95, 98, 123
- Hysteresis decrement, 20
 dielectric, 20, 138
- I
- Ignition characteristic, 238
 voltage, 64, 232
- Impressed oscillations, 85
- Impulse excitation by means of conden-
 sers, 183
 general consideration of, 182
 in true sense of the words, 182
 used for measuring purposes, 122,
 182
- Indicating circuit, 107
- Indicators of electromagnetic waves, 272
et seq.
- Induced currents, damping due to, 23,
 120, 168
- Inductive coils for high frequencies, 62,
 291, 323
- Initial amplitude, 13
- Insulation for high frequencies, 66 *et seq.*
 of antennæ, 168
- Interference between radio stations, 328,
 336, 366
 preventer, 323
- Intermediate circuit in Wien transmitter,
 186
- Interrupter in the antenna for tone trans-
 mission, 378
 in the supply circuit, 124, 194
 in the receiver, 333
- Ionization of the atmosphere, effect of,
 on the waves, 264 *et seq.*
- ISAKOW, L., 417
- IVES, J. E., Detectors, 280 *et seq.*
 Wavemeter, 125
- J
- JACKSON, H. B., 259
- JACOVIELLO, F., 420
- Jarring, effect of, on detectors, 301
- JEANCE, R., 371

- JÉGOU, P., 424
 JERVIS-SMITH, F., Compressed air condenser, 412
 gap, 418
 Jigger, 308
 JOLLOS, A., 417, 426
 JONAS, G., 416
- K
- KAISER, J., 415
 KALÄHNE, A., 415
 KANN, L., Dynamometer effect, 417
 Zero method for determination of decrement, 116
 KEMPE, W., 413
 KENNELLY, A. E., 422
 KEY, 202
 Relay, 203
 KIEBITZ, F., Arc generator, 226
 Experiments on directive telegraphy, 422, 426
 Ground antennæ, 365
 resistance, 417
 Receiver connections, 424
 KIMURA, S., 415
 KINRAIDE, T. B., 418
 KINTNER, S. M., Bolometer, 423
 Breakdown potential and gap length, 412
 KIRCHHOFF'S "Telegraph Equation," 410
 KLEMENČIČ, Thermocouple, 74
 Knockroe, station at, 225, 227
 KOEPEL, A., Adjustable condenser, 60
 Coherer, 278, *et seq.*
 KORDA, 412
- L
- LAHMEYER WORKS, 379
 LANGE, H., 418
 Leakage discharge. *See Brush discharge.*
 LEBEDEV, P., 75
 LECHER, E., Circuit arrangement, Lecher's wires, Lecher's system, 110, 163, 249
 Wave propagation along earth's surface, 421
 Length of gap, maximum, 64 *et seq.*, 399, 400
 Lengthening coils, 166
 LENZ, W., 411
 LEPEL, E. VON, Quenched spark gap having plate electrodes, 187
 LEPEL, E. VON, Wireless telephony, 371
 LINDEMANN, R., Effective resistance with oscillating currents, 411 *et seq.*
 Measurements with undamped oscillations, 416
 Lineal oscillator, transmitter, 24 *et seq.*, 163
 Liquid barretter, 272
 Load of condensers, so-called energy (W_c), 21
 Location, determination of, by radiotelegraphy, 367 *et seq.*
 LODGE, O., Resonance method for frequency determination, 106
 and A. MUIRHEAD, Counterpoise, 417
 Mercury coherer, 278
 Recording reception, 294 *et seq.*
 Tuned telegraphy, 310
 Umbrella antennæ, 152
 LOEWE, S., 114, 119
 LOEWY, H., 421
 Loose coupling, 81
 of oscillator and closed circuit, 84
 of two oscillators, 85 *et seq.*
 with undamped oscillations, 100
 LORENZ, C., Adjustable condenser, 61 *et seq.*
 Call signal device, 424
 Coupling coils, 84
 Discharge analyzer, 69
 Impulse spark gap, 192
 Interrupter, 183
 Multitone transmitter, 229 *et seq.*
 Photographic recorder, 295
 Poulsen arc generator, 222, 229
 Receiver for undamped oscillations, 333
 Thermal detector, 273
 Ticker, 334 *et seq.*
 Tone transmitter for undamped oscillations, 378
 Variometer, 53
 Wavemeter, 125, 183
 LORING, F. G., 419
 LUBOWSKY, H., 418
 LUDEWIG, P., Determination of decrement and degree of coupling, 416
 Experiments with detectors, 424
 Radio communication with airships, 418

M

- MACDONALD, H., 422
- Machines, high frequency. See *Generators, alternators.*
- MACKOWER, A. J. See *Eccles.*
- MACKŮ, B., Connections for quenched gap transmitter, 145
 Coupled circuits, 145, 415, 417
 Rupture of sparks, 117
 Theory of the Goldschmidt high frequency machine, 419
 of the resonance curves, 415
- MADLUNG, E., 423
- Magnetic blow-out, 187, 240, 242 *et seq.*
 coupling, 79
- MAJORANA, Q., Hydraulic microphone, 373
 Radio-telephony, 371, 373, 377
- MANDELSTAM, L., Plotting curves with aid of Braun tube, 408
 and H. BRANDES, Loose coupling in receiver, 322
 and N. PAPALEXI, Dynamometer effect and its application, 132
 Production of a desired phase difference, 353
- MARCH, H. W., 256
- MARCONI, G. and MARCONI WIRELESS TEL. CO.:
 Adjustable condenser, 61
 Antennæ, 151
 Bent antenna, 356 *et seq.*
 Coherers, 277
 Condensers as used in stations, 179
 Day and night transmission compared, 265 *et seq.*
 Duplex and multiplex operation, 324 *et seq.*
 Earth arrester, 424
 Jigger, transformer in the receiver, 308
 Magnetic detector, 274 *et seq.*
 Protection against atmospheric disturbances, 326 *et seq.*
 Rapidity of telegraphing, 301
 Receivers, 307 *et seq.*, 310 *et seq.*
 Rotating spark gap, 203 *et seq.*, 211
 Separated transmitting and receiving antenna, 356, 357, 382
 Transatlantic stations, 199, 208, 227, 266, 356
 Transmitter, 173, 208 *et seq.*
- MARCONI, G. and MARCONI WIRELESS TEL. CO.:
 Use of incandescent filament type of detectors, 284
 Wavemeter (and decremeter), 125 *et seq.*
- MARESCA, 409
- MASSIE, W. W., 428
- Maximum amplitude with close coupling, 92, 93
 with loose coupling, 86, 87
- Measuring circuit, 107 *et seq.*, 119, 124
- Mechanical quenching, mechanically quenched gap, 182, 204 *et seq.*
 resonance, 330 *et seq.*
- MEISSNER, A., Compass, Telefunken radio, 368 *et seq.*
 Eddy currents in insulating materials, 409
 Quenched gap transmitter with auxiliary ignition, 377, 378
 Testing of coils, 113
- Mercury arc lamp used as quenched gap, 95, 123
 turbine interrupter, 124, 194, 195
- Metallic granular coherer, 276, 298, 300
- Microphone contact, 279
 for radio-telephony, 373 *et seq.*
- Mirror for directive transmission, 340
 rotating, for photographing spark image, 3
- MOELLER, H. G., 411
- MONASCH, B., Dissipation of energy in condensers, 409
 and H. RAUSCH VON TRAUBENBERG, measurements with undamped oscillations, 416
- MONCKTON, C. C. F., 419
- MONTEL, A., 410
- MOSCICKI condensers, 56, 179, 412
- MOSLER, H., Day and night transmission compared, 422
 Radio communication with air ships, 418
 Receiver connections, 425
- Mountains, effect of, on wave propagation, 258 *et seq.*
- MUIRHEAD, A. See *Lodge.*
- MÜLLER, C., Breakdown potential and gap length, 400, 412
- Multiple antennæ, 151, 341 *et seq.*
 spark gap, 20, 98
 tuning apparatus, 311

Multiplex radio-telegraphy, 324 *et seq.*
 Multitone transmitter, 229 *et seq.*

N

NASMYTH, G. W., 421
 NATIONAL ELECTRIC SIGNALING CO.,
 Brant Rock, station at, 152, 165
 Compressed air condensers, 55,
 179
 Detectors, 273, 281
 Rotating spark gap, 204
 Secrecy of messages, 323, 324, 330
 Natural oscillations of condenser cir-
 cuits, 1 *et seq.*
 of inductive coils, 33
 of open oscillators, antennæ, 24 *et*
seq., 85 *et seq.*, 164 *et seq.*
 Nauen, station at, 64, 152, 155, 158, 168,
 179, 193, 198
 NERNST, W., Electrolytic detector, 280
 Resistances, 199
 NESPER, E., Detectors, 423
 Frequency and damping meters,
 417
 Impulse excitation, 182
 Marconi stations, 419
 Radio apparatus, 412
 Receiver connections, 425
 NICHOLSON, J. W., Effect of earth's cur-
 vature on wave propagation,
 255
 Effective resistance of coils, 411
 Node of current and of potential, 25
 NORDMEYER, P., 409

O

Open oscillators, 24 *et seq.*
 field of, 35 *et seq.*
 general properties of, 34 *et seq.*
 grounding of, 46, 157 *et seq.*
 with condensers, 43, 46
 with end capacity, 41 *et seq.*
 with inductive coils, 45
 Orientation by means of radio-telegraphy,
 367 *et seq.*
 ORT, K., 408
 Oscillation curves, 2, 389 *et seq.*
 valve, 284
 Oscillators, lineal, 24 *et seq.*
 open, 24 *et seq.*

Oscillograph, 4
 OUDIN'S resonator, 175
 Overloading detectors, 301

P

PAPALEXI, N. and L. MANDELSTAM,
 Dynamometer effect and its
 application, 132 *et seq.*
 Production of any desired phase
 difference, 353 *et seq.*
 Parallel, condensers in, 6 *et seq.*
 resistance method, 78
 Partial discharge sparks, 69
 PAUL, ROBERT W., Galvanometer, 73
 Interrupter, 183
 PEDERSEN, P. O., Frequency of Poulsen
 transmitter, 421
 Radio-telephony, 426
 Rapid telegraphy, 229, 302, 323, 337
 Signaling device for Poulsen trans-
 mitter, 228
 PELLIN, F., 427
 PÉRI, 125, 412
 Perikon detector, 282, 287
 Period of a condenser circuit, natural, 5
et seq.
 PETERSEN, W., 409
 PETIT, G. E., 352
 PEUCKERT, W., Magnetic detector, 275
 Quenched gap transmitter, 122, 192
 Phase displacement, method of securing
 any desired, 352 *et seq.*
 Photographic recorder, 295
 PHYSIKALISCH-TECHNISCHE REICHANS-
 TALT, Poulsen arc, 226
 PICHON, P., Blower for quenched spark
 gap, 187
 PICKARD, G. H., Detectors, 273, 282, 423
 PIERCE, G. W., Detectors, 282, 423
 Investigation of, 281, 283
 Mercury arc lamp used as spark gap,
 416
 "Principles of Wireless Telegraphy,"
 408
 Plate condensers, 54
 Plates or discs, gap, 187 *et seq.*
 POINCARÉ, H., 255
 Polar lights, effect of, on wave propaga-
 tion, 264
 Potential, anti-node of, 25
 distribution curve of, 25
 node of, 25

- Potentiometer, 290
 POULSEN, V., Arc method of generating undamped oscillations, 220 *et seq.*
 Interrupter in the receiver, 231 *et seq.*, 420
 Radio-telephony, 371, 374 *et seq.*
 Ticker, 334 *et seq.*
 Tone transmitter, 427
 Transmitters, commercial form of, 222 *et seq.*
 Propagation of waves along earth's surface, 246 *et seq.*
 velocity of, 26, 255
 Pulsations obtained with close coupling, 89, 95 *et seq.*
 tone reception by means of, 335
 transmission by means of, 378
- Q
- Quadrant electrometer for energy determination, 201
 Quasi-stationary current, 25
 Quenched spark, 93
 gap, 95 *et seq.*, 186 *et seq.*
 circuit used for measuring purposes, 120, 122, 182
 transmitter, 173, 182 *et seq.*, 198
 Quenching action, 93, 148 *et seq.*
 mechanical, 182, 206
 tube, 95
- R
- Radiation, 31, 39 *et seq.*
 decrement of antennæ, 167 *et seq.*
 of condenser circuits, 11
 of lineal oscillators, 31
 resistance of antennæ, 169 *et seq.*, 382
 of open oscillators, 40
 Radio-goniometer, 350, 367 *et seq.*
 Rain, effect of, on wave propagation, 260 *et seq.*
 Range of transmission, 271, 305, 314
 Rapid telegraph apparatus, 203, 229, 302
 RASCH, E., 428
 RAU, H., Experiments with quenched spark gaps, 96, 187, 417
 Photographing spark in coupled circuits, 89, 95
 RAUTENKRANZ, J., 413
 RAYLEIGH, LORD, 393
 Receiver, receiving circuits, general, 303 *et seq.*
 for double wave transmitter, 177, 314
 for radio telephony, 374 *et seq.*
 for tuned telegraphy, 310 *et seq.*
 for undamped oscillations, 332 *et seq.*
 Reception of signals, methods of reception, 290 *et seq.*
 Recombination of ions, 97
 Recorder, recording receiver, 167 *et seq.*, 302
 Rectifier, rectifying action, 283, 286, 288
 cell used for frequency transformation, 379
 Reflection of electromagnetic waves, 262, 263
 Reflector for directing waves, 340
 REICH, M., Ground resistance, ground currents, 417
 Radiation resistance of antennæ, 170
 and H. TH. SIMON, Arc method, 420
 Reignition in oscillating arc, 236
 REIN, H., "Radiotegraphisches Praktikum," 408
 Vieltonsender (multitone transmitter), 420
 Relays, 296 *et seq.*
 Reliability of detectors, 300, 301
 REMPP, G., Metereological experiments with radio-telegraphy, 427
 Spark-gap decrement, 409
 RENDAHL, R., Mercury arc lamp used as quenched spark gap, 95
 Variometer, 54
 Resistance, effective, 12, 47 *et seq.*, 396
 equivalent, 85, 120
 of coils, 50 *et seq.*
 of open oscillators antennæ, 41, 169
 wires, 398
 Resonance, 85
 curve of the current effect, 104 *et seq.*
 of the dynamometer effect, 132 *et seq.*
 of the receiver, 316
 curves, abnormal forms of the, 116 *et seq.*
 inductor, coil, 124, 196
 method for determining the decrement, 113 *et seq.*, 135
 the frequency, 106 *et seq.*, 134
 the spark-gap decrement, 16
 sharpness, 105, 405
 transformer, 196

- Responder, 279, 280
 Resultant capacity, 6 *et seq.*
 Retardation of discharge, 65, 208
 Rheostat for high frequency currents, 412
 RICHARDSON, H. W., and J. A. FLEMING, 416
 RICHARZ, F., and W. ZIEGLER, 408
 RICHTER, C., 409
 RIECKE, E., 420
 RIEGGER, H., Effect of spark on frequency and resonance curve, 9, 416
 Experiments with quenched spark gaps, 97, 147, 148
 Theory of the receiver, 321
 Ring coil, 52
 Rivers, effect of, on wave propagation, 262
 ROGER, E., and F. DUCRETET, Condensers, 179
 Rotating spark gap, 204
 ROHMANN, H., Application of resonance curve of the dynamometer effect, 417
 Experiments with quenched sparks, 415
 ROSA, E. B., 393
 and F. W. GROVER, 411
 ROSCHANSKY, D., Amplitude curve for condenser circuits with spark gap, 14
 Sequence of variations of the gap potential, 15, 392
 ROSSI, A. S., 275
 Rotating spark gaps, 196, 203 *et seq.*
 ROUND, H. J., 422
 RÜDENBERG, R., High frequency machine, 420
 Radiation resistance of open oscillators or antennæ, 40
 Theory of the receiver, 306
 RUHMER, E., 426
 Rupture of spark, 16, 117, 124, 206
 RUSCH, E., 419
 RUSSEL, J., 423
- S
- SACHS, S., 423
 Safety factor for commercial service, 271
 SCHAPIRA, C., 420
 SCHELLER, O., Call signal for radio-telephone work, 427
 Fly-wheel connection, 420
 Quenched spark gap, 192
 SCHLOEMILCH, W., Detectors, 273, 277, 280, 301
 SCHMIDT, H., 421
 SCHMIDT, K. E. F., Bolometer, 413
 Directive antennæ, 426
 Spark gap damping, 409
 SCHWARZHAUPT, P., Atmospheric disturbances, 425
 Experiences as to range of operation, 422
 Screening to secure directive transmission, attempts at, 340 *et seq.*
 Sea water, propagation of waves over, 246 *et seq.*
 Secrecy of messages, 323 *et seq.*, 328 *et seq.*, 336, 365 *et seq.*
 sender, 323 *et seq.*
 SEIBT, G., Adjustable condenser, 60
 Connections for quenched gap transmitter, 418
 Oscillations of coils, 409
 Radio-telephony, 427
 Resonance inductor, 415
 Variometer, 53
 Zero method for determining the frequency, 416
 Self-induction, adjustable, 51 *et seq.*
 coefficient of, 47
 effective coefficient of, 48
 equations for coefficient of, 393
 measurement of coefficient of, for open oscillators or antennæ, 112 *et seq.*
 unit of, 6
 Sensitiveness of detectors and ticker, 289 *et seq.*, 300 *et seq.*, 334
 Series connection of condensers, 6 *et seq.*
 spark gap, 20, 98, 189
 Ship antennæ, 153 *et seq.*, 165, 168
 SHOEMAKER, H., 427
 Short-circuit loop dynamometer, 136
 spark gap, 207
 SIEWERT, 417
 SIMON, H., 424
 SIMON, H. TH., Arc, characteristics of the, 428
 generator, 222
 method for producing undamped oscillations, 231, 420
 Mercury arc lamp used as spark gap, 416

- SIMON, H. TH., and M. REICH, Arc
method, 420
- SIMONS, K., 409
- Simple antennæ, 150, 169
- Siphon recorder, 294
- Skin effect, 47
- SLABY, A., Coupled circuits, 414
Receiver for tuned oscillations, 313
- Société française radioélectrique, 419
- SOLFF, K., Data on antennæ, 417
Radio communication with airships,
418
- SOMMERFELD, A., Coils for high frequency,
411
Propagation of electromagnetic
waves, 248 *et seq.*, 421
- Sound intensifier, 291 *et seq.*, 297, 331
- Source of energy supplied to radio trans-
mitters, 199 *et seq.*
- Space waves, 249
- Spark, 1
constants, 14, 392
damping, 15
effect of the, on the frequency, 9
gap, 1, 180
decrement, 15
micrometer, 66
quenched. See *Quenched.*
resistance, 15
with rotating electrodes, 203 *et seq.*
potential, 14, 392
the term, compared with arc, 245
- Speed of telegraphing, 302
- SQUIER, O., 303, 424
- "Static." See *Atmospheric disturbances*
characteristic of the arc, 231
- Station tester, 183
- Stationary waves, 26
- STEINHAUS, W., 413
- STONE, J. ST., Directive antennæ, 345
Receivers having several condenser
circuits, 425
Theory of coupled circuits, 415
- STRASSER, B., 393
- Stray energy coefficient, 257
- Straying of energy along earth's surface,
256
- String galvanometer, 296
- STUFF, W., 408
- SUBKIS, S., 101, 239
- Substitution method for determining
spark-gap resistance, 16 *et seq.*
- Sunlight. See *Daylight.*
- Supply circuit, 199 *et seq.*
- Surface waves, 249
- SUTTON, H., 423
- SZIVESSY, G., 416
- T
- TALSCH, E., 415
- Tapper, 298
- TAYLOR, J. E., Atmospheric disturbances,
425
Telephonic reception, 424
and W. DUDDALL, 260, 269, 272, 273
- TELEFUNKEN. See *Gesellschaft für draht-
lose Telegraphie.*
compass,
Telephone relay, 291 *et seq.*, 374
- Telephonic reception of radio signals,
290 *et seq.*
- Telephony, wireless, 370 *et seq.*
- TESLA, N., Arc method, 123
Braided wires, 49
- Thermal detectors, wave detectors, 273
et seq.
galvanometer, 75 *et seq.*, 77, 272
- Thermocouple thermolement, 74 *et seq.*,
77, 273
- THÖRNBLAD, TH. G., 417
- THOMSON, EL., Arc method, 220
- THOMSON'S (SIR WM.) equation, 5, 8,
408
- Ticker, 334 *et seq.*
- TISSOT, C., Bolometer, 72, 272, 413, 422
Experiments on wave propagation,
269, 422
Investigation of detectors, 282 *et
seq.*, 423
Longitude determination by means
of radio signals, 427
Radio telephony, 427
time signals, 427
Rheostat for high frequency cur-
rents, 412
- TOEPLER, M., 412
- Tone intensifier. See *Sound intensifier.*
reception, 378
transmitter, 195, 198, 206, 230, 292,
297, 325, 328, 330, 377
- TOSI, A., and E. BELLINI, 347 *et seq.*, 367
- Transformation of frequency, 379
- Transmitter of Braun, 173, 175 *et seq.*
of Marconi (simple), 173 *et seq.*
of Wien, 173, 182 *et seq.*, 209 *et seq.*

- TRAUBENBERG, H. RAUSCH VON, Poulsen generator, 222
 Spark-gap resistance, 409
 and B. MONASCH, Measurements with undamped oscillations, 416
 Trees used as receiving antennæ, 303
 Triplex reception with one antenna, 425
 TRUE, H., 158, 163
 Tuned telegraphy, 310 *et seq.*, 328 *et seq.*
 Tuning, 85, 314
 coils for, 166, 316, 382
 condensers for, 167
 sharpness of, 314, 316 *et seq.*
 Turbine interrupter, mercury, 124, 194, 195
 TURPAIN, A., 422
 Two-wave transmitter, receiver for, 176 *et seq.*, 314 *et seq.*
- U
- ULLER, K., Specific conductivity of various materials, 421
 Wave propagation along earth's surface, 421
 Umbrella antennæ, 152, 169
 Undamped oscillations, 2
 as used for measuring purposes, 116, 119, 121, 225
 generated by alternating current machines, 213 *et seq.*
 by the arc method, 220 *et seq.*
 receivers for, 332 *et seq.*
 Unilateral transmitter for directive telegraphy, 345
 Untuned circuits, coupling of, 147
 Upper harmonic oscillations of lineal oscillators, 24 *et seq.*, 32
 of open oscillators, 24 *et seq.*
 UPSON, W. L., 428
- V
- Variometer, 53, 192
 Vector diagram applied to field of double transmitter, 284 *et seq.*, 286, 288, 342
 Velocity of wave propagation, 26, 255
 Vieltonsender. See *Multitone transmitter*.
 VOEGE, 77
 VOIGT, E., 412
 VOLLMEK, K., 241
- W
- WAGNER, K. W., 421
 WALTER, L. H., Detectors, 275, 279
 Distance effect characteristics, 425
 Experiments with Peuckert's generator, 419
 WARBURG, E., 65
 WASMUS, A., Determination of discharge frequency, 413
 Experiments with Peuckert's generator, 419
 Water, stream of, used as antenna, 150
 WATSON, E. A., 412
 Wattmeter for measuring energy, 201
 hot-wire, 71
 Wave indicators, 272 *et seq.*
 length, 26
 of condenser circuits, 386
 and corresponding frequency, 388
 relation of, to propagation, 251, 265 *et seq.*, 381
 Wavemeters, 125 *et seq.*
 Waves, advancing, 26, 29
 propagation of, along earth's surface, 246 *et seq.*
 stationary, 26
 Weather, effects of the, 168, 263 *et seq.*
 WEHNELT, A., 284, 424
 WEICKER, W., 400
 WEISS, P., 423
 WERTHEIM-SALOMONSON, 221
 WHEATSTONE rapid telegraph apparatus, 203
 WIEN, M., Acoustic resonance, 425
 Effect of spark on the frequency, 9
 Efficiency of coupled transmitters, 211
 Experiments with coupled circuits, 142, 147, 415
 Investigation of condensers, 57, 140, 409, 412
 Loose coupling, 87, 414
 for tuned telegraphy, 322
 Quenched gap transmitter, 93 *et seq.*, 182 *et seq.*, 208 *et seq.*
 Quenching tubes, 95
 Resonance curves, 416
 Spark-gap decrement, 18
 WILDMANN, 422
 WILSON, E., 423
 WOLF, M., 412

Z

- ZÉBRIKOFF, L., and C. E. GUYE, 392
- ZEHNDER, L., Effect of atmosphere on the waves, 422
Ground antennæ, 364
- ZENNECK, J., Action of bent Marconi antenna when receiving, 361
Amplitude curve of condenser circuits with spark gap, 13
Direct coupling, 414
- ZENNECK, J., Experiments with coupled circuits, 93, 142 *et seq.*
with directive telegraphy, 340
Field of electromagnetic waves at the earth's surface, 252
Frequency transformation, 379, 380
Wavemeter, 127
- ZIEGLER, W., and F. RICHARZ, 408
- ZÖLLICH, H., 413
- ZORN, W., 409



DATE

UNIVERSITY OF CALIFORNIA LIBRARY
BERKELEY

Return to desk from which borrowed.
This book is DUE on the last date stamped below.

Dec 27 48 P3

18 Sep '80 E1

REC'D LD

SEP 28 1960

~~REC'D LD~~

NOV 27 1970

REC. CIR. AUG 3 '78

TK 574
Z 4

373881

General

UNIVERSITY OF CALIFORNIA LIBRARY

UNIVERSITY OF CALIFORNIA
LIBRARY

UNIVERSITY OF CALIFORNIA
LIBRARY

